



Request for Competitive Sealed Proposals

for the

**Roof Replacement at
Houston Elementary School
AISD Project No. 18-0023-HOUST**



SECTION 01 1100 - SUMMARY OF WORK

PART 1 - GENERAL

1.1 RELATED DOCUMENTS

- A. Drawings and general provisions of the Contract, including General and Supplementary Conditions and Division 01 through Division 26 Specification Sections, apply to this Section.

1.2 SUMMARY

- A. This Section includes:
1. Work covered by the Contract Documents.
 2. Type of the Contract.
 3. Work under other contracts.
 4. Use of premises.
 5. Owner's occupancy requirements.
 6. Work restrictions.
 7. Specification formats and conventions.

1.3 PROJECT INFORMATION

- A. Project Identification: **Roof Replacement at
Houston Elementary School**
5409 Ponciana Dr., Austin, TX 78744
- B. Owner: **Austin Independent School District**
- C. Roof Consultant (Architect): **Hollon+Cannon Group, llc.**
11800 Highland Oaks Trail
Austin, Texas 78759
Contact **Jon Cannon, RRC, RRO, REWO, CDT**
Tel: (512) 300-0452
Email: jcannon@hollon-cannon.com.

1.4 WORK COVERED BY CONTRACT DOCUMENTS

- A. The Work of the Project is defined by the Contract Documents and consists of the following:
1. Roof repair and roof removal and replacement for areas indicated in documents.
 2. Furnishing of all labor, materials, services, equipment and appliances as indicated in the Drawings and Specifications.
 3. Provision of all items required for complete operating systems, including items not necessarily shown in these documents, but that can be reasonably inferred as being required for the complete operating system.
- B. The Contract Documents (Drawings and Specifications):
1. Indicate the basic quality of materials and quality of construction required for the entire project.
 2. Do not necessarily indicate or describe all Work required for completion of the Project. Contractor shall provide and install all incidentals reasonably inferable from the Contract Documents that are required for a complete Project.
 3. Describe the essential elements sufficiently to determine the scope of the Project.
- C. Type of Contract:

1. Project will be constructed under a single, prime contract.
2. Employ subcontractors for the disconnection, re-connection, and installation of all mechanical, electrical and gas line Work in conjunction with all Work required, or implied, to be performed by licensed mechanics of these disciplines:
3. Subcontractors of Contractor shall furnish to Contractor bonds covering faithful performance of subcontract Work and payment of all obligations thereunder, when Contractor is required to furnish such bonds to the Owner.
4. Subcontractors of Contractor shall purchase and maintain liability insurance that will protect him from claims, but not for less than limits of liability Contractor is required to provide to Owner.
5. The Contractor shall include in Contract Amount costs of supervision, coordination and monitoring of Work of his selected Subcontractors.

1.5 WORK UNDER SEPARATE CONTRACTS

- A. Cooperate fully with separate contractors so Work on those contracts may be carried out smoothly, without interfering with or delaying Work under this Contract. Coordinate the Work of this Contract with Work performed under separate contracts.

1.6 ACCESS TO SITE

- A. General: Contractor shall have limited use of premises for construction operations as indicated on Drawings by the Contract limits.
 1. Contractor shall be responsible for monitoring the use of premises by Contractor's employees and Subcontractors.
 2. Access routes for delivery of materials and equipment shall be as indicated by Owner. Do not use access routes other than those indicated, without written permission of the Owner.
 3. Assume full responsibility for the protection and safekeeping of Products under this Contract, stored on the site. Store materials and products only in those areas indicated for staging.
 4. Protect existing lawns, sidewalks, pavements, curbs and utilities subject to damage by Work under this Contract. Repair or replace any existing Work damaged by the Contractor.
 5. Parking areas for Contractor's personnel shall be on the project site to the extent it does not interfere with ongoing contract Work and is located in areas designated by the Owner.
- B. Condition of Existing Building: Maintain portions of existing building affected by construction operations in a weather-tight condition throughout construction period. Repair damage caused by construction operations.

1.7 COORDINATION WITH OCCUPANTS

- A. Owner Occupancy: Owner may occupy site and building(s) during entire construction period. Cooperate with Owner during construction operations to minimize conflicts and facilitate Owner usage. Perform the Work so as not to interfere with Owner's day-to-day operations. Maintain existing exits unless otherwise indicated.
 1. Maintain access to existing walkways, corridors, and other adjacent occupied or used facilities. Do not close or obstruct walkways, corridors, or other occupied or used facilities without written permission from Owner and approval of authorities having jurisdiction.
 2. Notify Owner not less than 72 hours in advance of activities that will affect Owner's operations.

1.8 WORK RESTRICTIONS

- A. On Site Work Hours: Work hours in general are between 7:00 am and 6:00 pm, Monday through Friday, unless an exception is granted by the Owner and Architect, or as otherwise defined by various Sections of these Specifications.

- B. Existing Utility Interruptions: Do not interrupt utilities serving facilities occupied by Owner or others unless permitted under the following conditions, and then only after arranging to provide temporary utility services according to requirements indicated:
 - 1. Notify Owner and Roofing Consultant, in writing, not less than 72 hours in advance of proposed utility interruptions.
 - 2. Do not proceed with utility interruptions without Owner or Roof Consultant's written permission.
- C. Nonsmoking Building: Smoking is not permitted on school property.
- D. Noise, Vibration, and Odors: Coordinate operations that may result in high levels of noise and vibration, odors or other disruption to Owner occupancy with Owner.
- E. Controlled Substances: Use of tobacco products and other controlled substances is not permitted.
- F. Employee Screening: Comply with Owner's requirements for screening of Contractor personnel working on Project site.

1.9 SPECIFICATION FORMATS AND CONVENTIONS

- A. Specification Format: The Specifications are organized into Divisions and Sections using the 50-division format and CSI/CSC's "MasterFormat" numbering system.
- B. Specification Content: The Specifications use certain conventions for the style of language and the intended meaning of certain terms, words and phrases when used in particular situations. These conventions are as follows:
 - 1. Abbreviated Language: Language used in the Specifications and other Contract Documents is abbreviated. Words and meanings shall be interpreted as appropriate. Words implied, but not stated, shall be inferred as the sense requires. Singular words shall be interpreted as plural, and plural words shall be interpreted as singular, where applicable, as the context of the Contract Documents indicates.
 - 2. Imperative mood and streamlined language are generally used in the Specifications. Requirements expressed in the imperative mood are to be performed by Contractor. Occasionally, the indicative or subjunctive mood may be used in the Section Text for clarity to describe responsibilities that must be fulfilled indirectly by Contractor or by others when so noted.
 - a. The words "shall," "shall be," or "shall comply with," depending on the context, are implied where a colon (:) is used within a sentence or phrase.

PART 2 - PRODUCTS (Not Used)

PART 3 - EXECUTION (Not Used)

END OF SECTION 01 1100

SECTION 01 2200 - PROPOSAL ITEMS

PART 1 - GENERAL

1.1 RELATED DOCUMENTS

- A. Drawings and general provisions of the Contract, including General and Supplementary Conditions and Division 01 through Division 26 Specification Sections, apply to this Section.

1.2 SUMMARY

- A. Section includes administrative and procedural requirements for unit prices.

1.3 DEFINITIONS

- A. **Base Proposal No. 1:** Roof replacement at Roof Sections A-01 thru A-10 per Specifications, Plans and Details provided within the Contract Documents.
- B. Unit price is an amount proposed by bidders, stated on the Proposal Form and incorporated in the Agreement, applicable during the duration of the Work as a price per unit of measurement for materials, equipment, or services, or a portion of the Work, added to or deducted from the Contract Sum by appropriate modification, if the scope of Work or estimated quantities of Work required by the Contract Documents are increased or decreased.

1.4 PROCEDURES

- A. Unit prices include all necessary material, plus cost for delivery, installation, insurance, applicable taxes, overhead, and profit.
- B. Measurement and Payment: See individual Specification Sections for work that requires establishment of unit prices. Methods of measurement and payment for unit prices are specified in those Sections.
- C. Owner reserves the right to reject Contractor's measurement of work-in-place that involves use of established unit prices and to have this work measured, at Owner's expense, by an independent surveyor acceptable to Contractor.
- D. List of Unit Prices: A schedule of unit prices is included in Part 3. Specification Sections referenced in the schedule contain requirements for materials described under each unit price.

PART 2 - PRODUCTS (Not Used)

PART 3 - EXECUTION

3.1 SCHEDULE OF UNIT PRICES

<u>Unit Price No.</u>	<u>Description</u>	<u>Unit of Measure</u>
A. Unit Price No. 1	Install New Wood Nailers	Board Foot
B. Unit Price No. 2	Replace Wood Nailers	Board Foot
C. Unit Price No. 3	Install New Plywood	3/4"x4 ft.x8 ft. Sheet

D.	Unit Price No. 4	Small Metal Deck Repair (MDR-1)	100 sq. ft.
E.	Unit Price No. 5	Metal Deck Repair (MDR-2)	100 sq. ft.
F.	Unit Price No. 6	Metal Deck Repair (MDR-3)	Each

END OF SECTION 01 2200

SECTION 01 3110 - SPECIAL CONDITIONS

PART 1 - GENERAL

1.1 RELATED DOCUMENTS

- A. Drawings and general provisions of the Contract, including General and Supplementary Conditions and other Division 01 through Division 26 Specification Sections, apply to this Section.

1.2 CONDITIONS

- A. For convenience of reference and to facilitate letting of subcontracts, these Specifications are separated into sections. Such separation shall not operate to make Owner an arbitrator to establish subcontract limits between subcontractors.
- B. Execute all Work per the Contract Documents. Changes shall not be made without having first received written permission from the Architect. Where detailed information is lacking, and before proceeding with Work, refer the matter to the Architect for clarification.
- C. All Work shall be executed by mechanics skilled in their respective trades. Mechanics whose Work is unsatisfactory to the Owner, and/or Architect, or who are considered by the Owner to be careless, incompetent, unskilled, or otherwise objectionable, shall be dismissed from Work upon notice from the Architect and/or Owner at no additional cost to the Owner.
- D. The Owner will provide temporary water and electrical power required for the Work at no cost to the Contractor. The Contractor shall make necessary connections to existing fire plugs and/or tap the existing water service, and to power transformer or other power sources at the building site as required to perform his/her Work. Coordinate all connections with the Owner's maintenance department.
- E. Contractor shall be responsible for furnishing storage buildings, construction office, temporary security fencing, temporary air-tight partitions, bulletin boards, temporary fire protection, telephones, etc., as may be required to carry out construction operations.
- F. Construction-related access to the site shall be via the designated entrance at each location, or as shown on the Drawings. It shall be the responsibility of the Contractor to prevent damage to the existing paving system and to repair any and all damages. Any loss or damage to the Owner's property caused by the Contractor or his forces shall be repaired or replaced at no cost to the Owner. Grounds shall be restored to their original condition at the completion of the Project. Remove all fences, barricades, etc. Replace all vegetation damaged by construction operations, including grass, shrubs, and trees, to the satisfaction of the Owner.
- G. The Contractor shall remove trash and rubbish from the Owner's premises at the end of each workday. These materials shall be cleaned from the grounds and not be left in areas or locations other than containers specified for this purpose. Burning of combustibles will not be permitted.
- H. The Contractor agrees to cooperate and Work with the Owner to protect and limit exposure of students and employees from exposure to construction traffic, noise, and other elements which may prove disruptive or dangerous. The Contractor agrees to limit his Work hours for specific elements of the Work to those specified within the Contract Documents.

1.3 SCHEDULES

- A. Work may not routinely be scheduled to occur on Saturday or Sunday, except in the case of an emergency or lost time during any given Work week. Saturday Work, when made necessary by the loss of weekdays due to weather or other unanticipated events must be approved in advance by the Owner and Architect. The Contractor under such conditions shall advise the Architect in writing, delivered via email no later than 1:00 p.m., on the Wednesday prior to the weekend in which Work is proposed to be performed. The Contractor may not Work on any weekend day until such written request is approved.
- B. In the event of rain or other injurious condition to the building as may reasonably have been caused by the actions of the Contractor, the Contractor agrees to mobilize and provide all necessary Workers at the site to assist in limiting damages and correcting the conditions regardless of the hour or day of the week when such condition(s) occurs.
- C. During the course of the Work the Owner, with a minimum of three (3) days prior notification, may suspend the Work for a period of up to five (5) working days without incurring additional cost. These days may be taken individually or in any grouping convenient to the Owner.

1.4 RAIN DAY DETERMINATION

- A. "Normal rainfall" compiled by the State climatologist, based on U.S. Weather Bureau Records for Austin, Texas, is considered a part of the Calendar Day Contract, and is not a justification for an extension of time. Listed below are the number of days in each month for which no compensatory days for rainfall events ("Rain Days") in such months may be claimed:

January	8 days
February	8 days
March	7 days
April	7 days
May	9 days
June	6 days
July	5 days
August	5 days
September	7 days
October	7 days
November	7 days
December	7days

Rain days in addition to the baseline Rain Day determination described above will be considered by the Owner when submitted on the Owner's Time Extension Request Form subject to General Conditions, Article 7.1.

1.5 CONTRACTOR'S DAILY REPORTS

- A. Contractor shall complete daily reports on form provided and submit to the Owner with Applications for Payment or at Owners request.

1.6 ADDITIONAL SUBMITTAL REVIEW, FIELD OBSERVATIONS OR INSPECTIONS BY ARCHITECT

- A. In the event that the Contractor exceeds the Substantial Completion date - for whatever reason - it shall be responsible for reimbursing the Owner through authorized change order for all costs of the Architect's staff and expenses to carry on inspection duties at the rate performed during the project prior to that date. This method will also govern reimbursement to the Architect for additional "final" inspections necessitated by Contractor's failure to correct all "Items to be Completed or Corrected" on Substantial Completion punch lists.

- B. In the event that submittals require review more than once past the initial submittal for each section or item, the Contractor shall be responsible for reimbursing the Architect for all costs of submittal review for the third and all subsequent submittal reviews prior to each. The Architect shall inform the Contractor of the anticipated time required for such review and the Contractor shall provide payment in the form of a check made payable to the Architect for the anticipated time and expenses required prior to the third and/or other subsequent reviews. All submittals which are found to be unacceptable shall be returned to the Contractor at the Contractor's expense by common courier.
- C. The rate of reimbursement shall be as follows:
- | | |
|--|-------------------|
| Architect / Consultant | \$135.00 per hour |
| Construction Observer | \$ 85.00 per hour |
| Mileage | \$ 0.58 per mile |
| Travel Expenses (lodging, meals, etc.) | Cost plus 10% |
| Architect's Consultant Expenses | Cost plus 10% |
- D. The above costs, if necessary, may be deducted from any payments remaining due to the Contractor upon completion of the Work by duly authorized change order.

END OF SECTION 01 3110

SECTION 01 3150 - PROJECT MANAGEMENT AND COORDINATION

PART 1 - GENERAL

1.1 RELATED DOCUMENTS

- A. Drawings and general provisions of the Contract, including General and Supplementary Conditions and other Division 01 Specification Sections, apply to this Section.

1.2 SUMMARY

- A. Section includes administrative provisions for coordinating construction operations on Project including, but not limited to, the following:
 - 1. General coordination procedures.
 - 2. Requests for Information (RFIs).
 - 3. Project meetings.
- B. Each contractor shall participate in coordination requirements. Certain areas of responsibility are assigned to a specific contractor.

1.3 DEFINITIONS

- A. RFI: Request from Contractor seeking information required by or clarifications of the Contract Documents.

1.4 INFORMATIONAL SUBMITTALS

- A. Subcontract List: Prepare a written summary identifying individuals or firms proposed for each portion of the Work, including those who are to furnish products or equipment fabricated to a special design. Include the following information:
 - 1. Name, address, and telephone number of entity performing subcontract or supplying products.
- B. Key Personnel Names: Within 15 days of starting construction operations, submit a list of key personnel assignments, including superintendent and other personnel in attendance at Project site. Identify individuals and their duties and responsibilities; list addresses and telephone numbers, including home, office, and cellular telephone numbers and e-mail addresses.

1.5 GENERAL COORDINATION PROCEDURES

- A. Coordination: Coordinate construction operations included in different Sections of the Specifications to ensure efficient and orderly installation of each part of the Work. Coordinate construction operations, included in different Sections that depend on each other for proper installation, connection, and operation.
 - 1. Schedule construction operations in sequence required to obtain the best results where installation of one part of the Work depends on installation of other components, before or after its own installation.
 - 2. Coordinate installation of different components to ensure maximum performance and accessibility for required maintenance, service, and repair.
 - 3. Make adequate provisions to accommodate items scheduled for later installation.
- B. Prepare memoranda for distribution to each party involved, outlining special procedures required for coordination. Include such items as required notices, reports, and list of attendees at meetings.

1. Prepare similar memoranda for Owner and separate contractors if coordination of their Work is required.
- C. Administrative Procedures: Coordinate scheduling and timing of required administrative procedures with other construction activities to avoid conflicts and to ensure orderly progress of the Work. Such administrative activities include, but are not limited to, the following:
1. Preparation of Contractor's construction schedule.
 2. Preparation of the schedule of values.
 3. Installation and removal of temporary facilities and controls.
 4. Delivery and processing of submittals.
 5. Progress meetings.
 6. Pre-installation conferences.
 7. Project closeout activities.
 8. Startup and adjustment of systems.
- D. Conservation: Coordinate construction activities to ensure that operations are carried out with consideration given to conservation of energy, water, and materials. Coordinate use of temporary utilities to minimize waste.
1. Salvage materials and equipment involved in performance of, but not actually incorporated into, the Work. See other Sections for disposition of salvaged materials that are designated as Owner's property.
- 1.6 REQUESTS FOR INFORMATION (RFIs)
- A. General: Immediately on discovery of the need for additional information or interpretation of the Contract Documents, Contractor shall prepare and submit an RFI in the form specified.
1. Architect will return RFIs submitted to Architect by other entities controlled by Contractor with no response.
 2. Coordinate and submit RFIs in a prompt manner so as to avoid delays in Contractor's work or work of subcontractors.
- B. Content of the RFI: Include a detailed, legible description of item needing information or interpretation and the following:
1. Project name.
 2. Project number.
 3. Date.
 4. Name of Contractor.
 5. Name of Architect and Construction Manager.
 6. RFI number, numbered sequentially.
 7. RFI subject.
 8. Specification Section number and title and related paragraphs, as appropriate.
 9. Drawing number and detail references, as appropriate.
 10. Field dimensions and conditions, as appropriate.
 11. Contractor's suggested resolution. If Contractor's suggested resolution impacts the Contract Time or the Contract Sum, Contractor shall state impact in the RFI.
 12. Contractor's signature.
 13. Attachments: Include sketches, descriptions, measurements, photos, Product Data, Shop Drawings, coordination drawings, and other information necessary to fully describe items needing interpretation.
 - a. Include dimensions, thicknesses, structural grid references, and details of affected materials, assemblies, and attachments on attached sketches.
- C. RFI Forms: AIA Document G716.

- D. Architect's Action: Architect will review each RFI, determine action required, and respond. Allow seven working days for Architect's response for each RFI. RFIs received by Architect after 1:00 p.m. will be considered as received the following working day.
1. The following Contractor-generated RFIs will be returned without action:
 - a. Requests for approval of submittals.
 - b. Requests for approval of substitutions.
 - c. Requests for approval of Contractor's means and methods.
 - d. Requests for coordination information already indicated in the Contract Documents.
 - e. Requests for adjustments in the Contract Time or the Contract Sum.
 - f. Requests for interpretation of Architect's actions on submittals.
 - g. Incomplete RFIs or inaccurately prepared RFIs.
 2. Architect's action may include a request for additional information, in which case Architect's time for response will date from time of receipt of additional information.
 3. Architect's action on RFIs that may result in a change to the Contract Time or the Contract Sum may be eligible for Contractor to submit Change Proposal according to the General Conditions of the Contract.
 - a. If Contractor believes the RFI response warrants change in the Contract Time or the Contract Sum, notify Architect in writing within 10 days of receipt of the RFI response.
- E. RFI Log: Prepare, maintain, and submit a tabular log of RFIs organized by the RFI number. Submit log monthly along with payment applications.
1. Project name.
 2. Name and address of Contractor.
 3. Name and address of Architect.
 4. RFI number including RFIs that were returned without action or withdrawn.
 5. RFI description.
 6. Date the RFI was submitted.
 7. Date Architect's response was received.
- F. On receipt of Architect's action, update the RFI log and immediately distribute the RFI response to affected parties. Review response and notify Architect within seven days if Contractor disagrees with response.
1. Identification of related Minor Change in the Work, Construction Change Directive, and Proposal Request, as appropriate.
 2. Identification of related Field Order, Work Change Directive, and Proposal Request, as appropriate.

1.7 PROJECT MEETINGS

- A. General: Architect will schedule and conduct meetings and conferences at Project site unless otherwise indicated.
1. Attendees: Inform participants and others involved, and individuals whose presence is required, of date and time of each meeting. Notify Owner and Architect of scheduled meeting dates and times.
 2. Agenda: Prepare the meeting agenda. Distribute the agenda to all invited attendees.
 3. Minutes: Record significant discussions and agreements achieved. Distribute the meeting minutes to everyone concerned, including Owner and Architect, within three days of the meeting.
- B. Preconstruction Conference: A preconstruction conference will be scheduled before starting construction, at a time convenient to Owner and Architect.
1. Conduct the conference to review responsibilities and personnel assignments.
 2. Attendees: Authorized representatives of Owner, Construction Manager, Architect, and their consultants; Contractor and its superintendent; major subcontractors; suppliers; and other concerned parties shall attend the conference. Participants at the conference shall be familiar with Project and authorized to conclude matters relating to the Work.

3. Agenda: Discuss items of significance that could affect progress, including the following:
 - a. Tentative construction schedule.
 - b. Phasing.
 - c. Critical work sequencing and long-lead items.
 - d. Designation of key personnel and their duties.
 - e. Lines of communications.
 - f. Procedures for processing field decisions and Change Orders.
 - g. Procedures for RFIs.
 - h. Procedures for testing and inspecting.
 - i. Procedures for processing Applications for Payment.
 - j. Distribution of the Contract Documents.
 - k. Submittal procedures.
 - l. Preparation of record documents.
 - m. Use of the premises and existing building.
 - n. Work restrictions.
 - o. Working hours.
 - p. Owner's occupancy requirements.
 - q. Responsibility for temporary facilities and controls.
 - r. Procedures for moisture and mold control.
 - s. Procedures for disruptions and shutdowns.
 - t. Construction waste management and recycling.
 - u. Parking availability.
 - v. Office, work, and storage areas.
 - w. Equipment deliveries and priorities.
 - x. First aid.
 - y. Security.
 - z. Progress cleaning.

- C. Progress Meetings: Conduct progress meetings at regular intervals.
 1. Coordinate dates of meetings with preparation of payment requests.
 2. Attendees: In addition to representatives of Owner, Construction Manager, and Architect, each contractor, subcontractor, supplier, and other entity concerned with current progress or involved in planning, coordination, or performance of future activities shall be represented at these meetings. All participants at the meeting shall be familiar with Project and authorized to conclude matters relating to the Work.
 3. Agenda: Review and correct or approve minutes of previous progress meeting. Review other items of significance that could affect progress. Include topics for discussion as appropriate to status of Project.
 - a. Contractor's Construction Schedule: Review progress since the last meeting. Determine whether each activity is on time, ahead of schedule, or behind schedule, in relation to Contractor's construction schedule. Determine how construction behind schedule will be expedited; secure commitments from parties involved to do so. Discuss whether schedule revisions are required to ensure that current and subsequent activities will be completed within the Contract Time.
 - 1) Review schedule for next period.
 - b. Review present and future needs of each entity present, including the following:
 - 1) Interface requirements.
 - 2) Sequence of operations.
 - 3) Resolution of BIM component conflicts.
 - 4) Status of submittals.
 - 5) Deliveries.
 - 6) Off-site fabrication.
 - 7) Access.
 - 8) Site utilization.
 - 9) Temporary facilities and controls.
 - 10) Progress cleaning.

- 11) Quality and work standards.
 - 12) Status of correction of deficient items.
 - 13) Field observations.
 - 14) Status of RFIs.
 - 15) Status of proposal requests.
 - 16) Pending changes.
 - 17) Status of Change Orders.
 - 18) Pending claims and disputes.
 - 19) Documentation of information for payment requests.
4. Minutes: Architect will record and distribute the meeting minutes to each party present and to parties requiring information.
 - a. Schedule Updating: Revise Contractor's construction schedule after each progress meeting where revisions to the schedule have been made or recognized. Issue revised schedule concurrently with the report of each meeting.

1.8 PROJECT SUPERINTENDENT

- A. In addition to other duties imposed by these Specifications the Project Superintendent shall meet the following requirements:
 1. Show prior to the start of Work references from Owners of a minimum of five (5) previously completed jobs of similar size, complexity and construction cost.
 2. Show proficiency prior to the start of the Work that the Superintendent is fluent in the English language, or if not, provide a competent and approved interpreter for such purposes. The purpose of this clause is to assure adequate communications with all parties involved in the Work.
 3. The Project Superintendent shall be present at the project site at all times that any Work of this contract is underway. If the Project Superintendent must be away from the project site the Contractor shall first file written documentation of the absence with the Architect at least 48-hours in advance of the new replacement. The replacement, or acting Project Superintendent, shall meet the minimum requirements defined above and elsewhere in the Specifications for the Project Superintendent. The only exception to this shall be when the Contractor, an officer of the company with a majority share of ownership, shall be permitted to act as the Project Superintendent. A majority owner of the contracting company may act as the Project Superintendent for the entirety of the project.
 4. No Work shall be performed and no subcontractor(s) shall be permitted to Work at any time when the Project Superintendent is not present.

PART 2 - PRODUCTS (Not Used)

PART 3 - EXECUTION (Not Used)

END OF SECTION 01 3150

SECTION 01 3300 - SUBMITTAL PROCEDURES

PART 1 - GENERAL

1.1 RELATED DOCUMENTS

- A. Drawings and general provisions of the Contract, including General and Supplementary Conditions and other Division 01 Specification Sections, apply to this Section.

1.2 SUMMARY

- A. This Section includes:
 - 1. Procedures
 - 2. Construction Progress Schedule
 - 3. Shop Drawings
 - 4. Product Data
 - 5. Samples
 - 6. Manufacturer's Instructions
 - 7. Manufacturer's Certificates
 - 8. Schedule of Required Submittals

1.3 PROCEDURES - BEFORE PROPOSAL OPENING

No substitute systems or materials will be considered prior to bidding.

1.4 PROCEDURES - AFTER PROPOSAL OPENING

- A. Deliver submittals to: Hollon+Cannon Group, llc.
11800 Highland Oaks Trail
Austin, Texas 78759
- B. All submittals required for the project shall be submitted at the same time.
- C. Transmit each item under form acceptable to the Architect in this document. Identify Project, Contractor, Subcontractor and major suppliers. Identify pertinent drawing sheet and detail number, and specification section number as appropriate. Identify any and all deviations from Contract Documents. Provide separate 3-inch x 5-inch spaces for Contractor's certification stamp and for Architect's review stamp. Affix Contractor's certification stamp on all submittal sets.
- D. Submit submittal schedule at the same time as all other submittals.
- E. All submittals, including shop drawings, product data and samples for this project shall be submitted at the same time to the Architect and within ten (10) days after receipt of the Notice to Proceed.
- F. After Architect's review of submittal, revise and re-submit as required, identifying changes made since previous submittal.
- G. Distribute copies of reviewed submittals to concerned persons. Instruct recipients to promptly report any inability to comply with provisions.
- H. Bind sets of submittals in labeled three-ring binders identified on the outside with the project title, date, Contractor's, Architect's and Owner's names, and including a table of contents

corresponding to the Specification format, with all contents correlated.

1.5 CONSTRUCTION PROGRESS SCHEDULES

- A. Submit horizontal bar chart with separate bar for each major trade or operation, identifying first work day of each week.
- B. Submittal Schedule: Show submittal dates required for Shop Drawings, product data and samples and product delivery dates including those, if any, identified to be furnished by the Owner.

1.6 SHOP DRAWINGS

- A. Submit a minimum of four (4) sets, or a maximum of seven (7) sets of all shop drawings on opaque reproductions.
- B. Present in a clear and thorough manner. Title each Drawing with Project Name and the same information indicated for 1.4.H above. Identify each element of Drawings by reference to the corresponding sheet number and detail number in the Contract Documents.
- C. Identify field dimensions. Show relation to adjacent or critical features of Work.

1.7 PRODUCT DATA

- A. Submit a minimum of seven (7) sets of all product data.
- B. Submit only pages which are pertinent. Mark each copy of standard printed data with yellow highlighter or circling with red ink to identify pertinent products.
 - 1. Mark each item with the Specification Section number and Article number where it is specified in the Contract Documents.
 - 2. Product data not so marked will be returned without review, for re-submittal complying with the above requirements.
 - 3. Show reference standards, performance characteristics, and capacities; wiring and piping diagrams and controls; component parts; finishes; dimensions; and required clearances.
- C. Mark each proposed item in product data by circling or highlighting, and affix the corresponding Article and Paragraph designations from this Specification Section.
- D. Modify manufacturer standard schematic drawings and diagrams to supplement standard information and to provide information specifically applicable to the Work. Delete information not applicable.
- E. Clearly identify any deviations from the Contract Documents when submitted. Any items not identified shall be deemed to be items specified in the Contract Documents.

1.8 MANUFACTURER'S INSTRUCTIONS

When required in individual Specification Sections, submit manufacturer's printed instructions for delivery, storage, assembly, installation, start-up, adjusting and finishing in quantities specified for product data.

1.9 SAMPLES

- A. Submit full range of manufacturer's standard colors, textures and patterns for Owner's selection. Submit a minimum of four (4) sets and a maximum of seven (7) sets of all samples unless

otherwise indicated by these Specifications.

- B. Submit samples to illustrate functional characteristics of the product, with integral parts and attachment devices. Coordinate submittal of different categories for interfacing Work.
- C. Include identification on each sample, giving full information.
- D. Submit the number specified in respective Specification Section. Two (2) will be retained by the Architect. Reviewed samples which may be used in the Work are indicated in the Specification Section.

1.10 FIELD SAMPLES

Provide field samples of finishes at the project site as required by individual Specification Sections. Install sample complete and finished. Acceptable samples in place may be retained in completed Work.

1.11 CONTRACTOR REVIEW

- A. Review submittals prior to transmittal. Determine and verify field measurements, field construction criteria, manufacturer's catalog numbers and conformance of submittal with requirements of Contract Documents.
- B. Coordinate submittals with requirements of Work and of Contract Documents.
- C. Apply Contractor's stamp on each section of Shop Drawings and Product Data, and each sample label to certify compliance with requirements of Contract Documents. Notify Architect in writing at time of submittal, of any deviations from requirements of Contract Documents.
- D. The Contractor is encouraged not to fabricate products or begin Work which requires submittals until return of reviewed submittal with Architect's review stamp. Fabrication of items and beginning of Work when submittals have not been reviewed will be at the Contractor's risk.

1.12 SUBMITTAL REQUIREMENTS

- A. Transmit submittals in sequence to avoid delay in Work or Work of other contracts.
- B. Coordinate submittals into logical groupings to facilitate interrelation of the items.
- C. Submit under Architect approved transmittal letter. Identify Project by title and number. Identify Work and product by Specification Section and Article Number.

1.13 RE-SUBMITTAL REQUIREMENTS

- A. Make re-submittals under procedures specified for initial submittals. Identify changes made since previous submittal.
- B. Re-submittals beyond the initial and a second will be reviewed by the Architect and/or his consultants at the Contractor's expense.

1.14 ARCHITECT AND OWNER REVIEW

- A. The Architect and Owner and/or other authorized representative will review all submittals. Submittals will be returned to Contractor with Architect's review stamp affixed, and/or with the

indication of any changes which may need to be made, shown thereon, or with disapproval.

- B. The Architect's review of any such Submittal shall not relieve the Contractor from responsibility for deviations from Drawings or Specifications, nor shall it relieve him from responsibility for errors of any sort in the Submittal, nor shall it in any way diminish the Contractor's obligation to conduct the Work in accordance with the Contract Documents.
- C. Approval of samples shall be for design and appearance only, and such approval shall not relieve Contractor from any obligation as provided in the Contract Documents.

1.15 SCHEDULE OF REQUIRED SUBMITTALS

- A. The following is a list of the minimum submittals required for each section of the Specifications. This list is not intended to be comprehensive and is to be used only as a guide to the minimum requirements. It is intended that manufacturer's data sheets confirming the product to be used is required from the following listing. Where samples or shop drawings are required it is so indicated.
 - 1. **Section 06 1050 - Roof Carpentry**
 - a. Plywood.
 - b. Lumber treatment type and certification.
 - c. Stainless steel fasteners.
 - d. All other required fasteners.
 - 2. **Section 07 0151 - Roof Removal Procedures**
 - a. Demolition plan.
 - b. Accurate (to scale) site plan showing locations of dumpsters, trash chutes, dust collection system, fencing, etc.
 - 3. **Section 07220 - Roof Insulation**
 - a. Polyisocyanurate insulation
 - b. Roof cover board
 - c. Mechanical fasteners
 - d. Asphalt primer
 - e. Low rise foam adhesive
 - 4. **Section 07 5216 – Modified Bitumen Roof System**
 - a. Roof system design (calculations and fastener patterns)
 - b. Modified bitumen membranes and flashings
 - c. Insulation and cover board
 - d. Installer's and manufacturer's warranties
 - e. Asphalt based products
 - f. Fasteners
 - 5. **Section 07 5600 – Fluid Applied Flashing**
 - a. Membrane resin.
 - b. Flashing reinforcement.
 - 6. **Section 07 6200 - Flashing and Sheet Metal**
 - a. Pre-finished Galvalume® metal.
 - b. Galvalume® metal.
 - c. Galvanized metal.
 - d. Metal wall panels.
 - e. Solder and flux.
 - f. Polyurethane sealant.
 - g. Penetration Sealer System.
 - h. Fasteners - Include pop rivets, neoprene-head screws, stainless steel drive pins, drive pin washers, roofing nails, termination bars, straps and any other special fasteners.
 - 7. **Section 07 7200 - Roofing Accessories**
 - a. Equipment support.

- c. Small pipe support assembly.
- d. Roller Assemblies.
- e. Small conduit support assemblies (channels, corners, attachment, etc.).
- 8. **Section 07 9100 - Joint Sealers**
 - a. Backer rod.
 - b. Sealant.
- 9. **Division 22 – Plumbing**
 - a. All materials proposed for incorporation into the Work.
 - b. Copy of permit from City of Belton, Texas.
- 10. **Division 23 – Mechanical**
 - a. All materials proposed for incorporation into the Work.
 - b. Copy of permit from City of Austin, Texas.
- 11. **Division 26 – Electrical**
 - a. All materials proposed for incorporation into the Work.
 - b. Copy of permit from City of Austin, Texas.
- 12. **Material Safety Data Sheets (MSDS)**

Provide three (3) bound sets of manufacturer's material safety data sheets (MSDS), separate from all other submittals. MSDS shall be provided for all materials associated with or employed in the Work at the project site. MSDS shall be categorized by specification section and include separate tabs for each section. Tables of contents shall be provided for the overall manual and contents within each individual section.

PART 2 - PRODUCTS (Not Used)

PART 3 - EXECUTION (Not Used)

END OF SECTION 01 3300

SECTION 01 4000 - QUALITY REQUIREMENTS

PART 1 - GENERAL

1.1 RELATED DOCUMENTS

- A. Drawings and general provisions of the Contract, including General and Supplementary Conditions and other Division 01 Specification Sections, apply to this Section.

1.2 SUMMARY

- A. This Section includes:
 1. General Quality Control
 2. Workmanship
 3. Manufacturer's Instructions
 4. Manufacturer's Certificates
 5. Field Samples
 6. Manufacturer's Field Services
 7. Testing Laboratory Services

1.3 QUALITY CONTROL - GENERAL

- A. Maintain quality control over supervision, subcontractors, suppliers, manufacturers, products, services, site conditions and workmanship to produce Work of specified quality.
- B. Perform all Work to the level of quality specified by Standards in individual Specification Sections.
- C. The Work will be observed by the Architect for compliance with approved submittals and level of quality specified.
- D. The Work, or any part thereof, deemed by the Architect to be unsuitable or below the required level of quality, shall be replaced or repaired by the Contractor at no additional cost to the Owner.

1.4 WORKMANSHIP

- A. Comply with industry standards for high quality commercial buildings, except when more restrictive tolerances or specified requirements indicate more rigid standards or more precise workmanship.
- B. Perform Work using persons qualified to produce workmanship of specified quality.
- C. Secure products in place with positive anchorage devices designed and sized to withstand stresses, vibrations, and racking.

1.5 MANUFACTURERS' INSTRUCTIONS

Comply with manufacturers' instructions in full detail, including each step in the sequence. Should instructions conflict with Contract Documents, request clarification from the Architect before proceeding with Work.

1.6 MANUFACTURERS' CERTIFICATES

When required by individual Specification Sections, submit five (5) copies of manufacturers' certificates that state products meet or exceed specified requirements.

1.7 QUALITY CONTROL MONITORING

Owner will retain quality control monitoring of the scheduled operations on a part-time basis.

1.8 MANUFACTURER'S FIELD SERVICES

- A. When specified in respective Sections, require suppliers, manufacturers, or vendors to provide qualified personnel to observe field conditions, conditions of surfaces and installation, quality of workmanship, start-up of equipment, or testing, adjusting and balancing of equipment as applicable, and to make appropriate recommendations.
- B. When required by the individual Sections, manufacturer, supplier, or vendor representatives shall submit written reports to the Architect, listing observations and recommendations.

1.9 TESTING LABORATORY SERVICES

- A. The Owner shall employ and pay for the services of an Independent Testing Laboratory to perform inspections, tests, and other services required by individual Specification Sections.
- B. Services will be performed in accordance with requirements of governing authorities and with specified standards.
- C. Reports of all testing will be submitted to the Architect. Reports shall reflect observations and results of testing and indicating compliance or non-compliance with specified standards and with the Contract Documents.
- D. The Contractor and all Subcontractors shall cooperate with testing laboratory personnel by furnishing safe access to the Work, tools, samples of materials, etc., and assistance as requested.
 - 1. Notify Owner and Testing Lab 48 hours prior to expected time for operations requiring testing and/or inspection services.
 - 2. Make arrangements with Testing Lab and pay for all additional samples and tests produced for the Contractor's convenience, and for all those that may have failed.

PART 2 – PRODUCTS (Not Used)

PART 3 – EXECUTION (Not Used)

END OF SECTION 01 4000

SECTION 01 4200 - REFERENCE STANDARDS

PART 1 - GENERAL

1.1 RELATED DOCUMENTS

- A. Drawings and general provisions of the Contract, including General and Supplementary Conditions and Division 01 through Division 26 Specification Sections, apply to this Section.

1.2 DEFINITIONS

- A. General: Basic Contract definitions are included in the Conditions of the Contract.
- B. "Approved": When used to convey Architect's action on Contractor's submittals, applications, and requests, "approved" is limited to Architect's duties and responsibilities as stated in the Conditions of the Contract.
- C. "Directed": A command or instruction by Architect. Other terms including "requested," "authorized," "selected," "required," and "permitted" have the same meaning as "directed."
- D. "Indicated": Requirements expressed by graphic representations or in written form on Drawings, in Specifications, and in other Contract Documents. Other terms including "shown," "noted," "scheduled," and "specified" have the same meaning as "indicated."
- E. "Regulations": Laws, ordinances, statutes, and lawful orders issued by authorities having jurisdiction, and rules, conventions, and agreements within the construction industry that control performance of the Work.
- F. "Furnish": Supply and deliver to Project site, ready for unloading, unpacking, assembly, installation and similar operations.
- G. "Install": Operations at Project site including unloading, temporarily storing, unpacking, assembling, erecting, placing, anchoring, applying, working to dimension, finishing, curing, protecting, cleaning, and similar operations.
- H. "Provide": Furnish and install, complete and ready for the intended use.
- I. "Project Site": Space available for performing construction activities. The extent of Project site is shown on Drawings and may or may not be identical with the description of the land on which Project is to be built.

1.3 INDUSTRY STANDARDS

- A. Applicability of Standards: Unless the Contract Documents include more stringent requirements, applicable construction industry standards have the same force and effect as if bound or copied directly into the Contract Documents to the extent referenced. Such standards are made a part of the Contract Documents by reference.
- B. Publication Dates: Comply with standards in effect as of date of the Contract Documents unless otherwise indicated.
- C. Copies of Standards: Each entity engaged in construction on Project should be familiar with industry standards applicable to its construction activity. Copies of applicable standards are not bound with the Contract Documents.

1. Where copies of standards are needed to perform a required construction activity, obtain copies directly from publication source.

1.4 ABBREVIATIONS AND ACRONYMS

- A. Industry Organizations: Where abbreviations and acronyms are used in Specifications or other Contract Documents, they shall mean the recognized name of the entities in the following list, under Article 1.5.
- B. Names, telephone numbers and Web sites are subject to change and are believed to be accurate and up-to-date as of the date of the Contract Documents.

1.5 SCHEDULE OF REFERENCES

AISC	American Iron and Steel Institute 1000 16th St. N.W., Washington, DC 20036
AISC	American Institute of Steel Construction, Inc. 400 N. Michigan, 8th Floor, Chicago, IL 60611
ANSI	American National Standards Institute 1430 Broadway, New York, NY 10018
APA	American Plywood Association 7011 S.19th St., Tacoma, WA 98466
ASC	Adhesive and Sealant Council
ASCE	American Society of Civil Engineers
ASHRAE	American Society of Heating, Refrigeration and Air Conditioning Engineers
ASME	American Society of Mechanical Engineers
ASTM	American Society for Testing & Materials
AWPA	American Wood Preservers' Association 7745 Old Georgetown, Bethesda, MD 20014
FM	Factory Mutual Corporation
FS	Federal Specifications and Federal Standards
NBS	National Bureau of Standards (U.S. Department of Commerce)
NEC	National Electric Code, NFPA 70-84
NEMA	National Electrical Manufacturers Association
NFPA	National Fire Protection Association
NIOSH	National Institute of Occupational Safety and Health
NRCA	National Roofing Contractor's Association
NSF	National Sanitation Foundation
OSHA	Occupational Safety and Health Administration and/or Act
PS	Product Standards of NBS
SDI	Steel Deck Institute
	SMACNA - Sheet Metal and Air Conditioning Contractor's National Association - Architectural Sheet Metal Manual
UL	Underwriters Laboratories

PART 2 – PRODUCTS (Not Used)

PART 3 – EXECUTION (Not Used)

END OF SECTION 01 4200

SECTION 01 5000 - TEMPORARY FACILITIES AND CONTROLS

PART 1 - GENERAL

1.1 RELATED DOCUMENTS

- A. Drawings and general provisions of the Contract, including General and Supplementary Conditions and other Division 01 Specification Sections, apply to this Section.

1.2 SUMMARY

- A. This Section includes:
 1. Electricity and Lighting
 2. Ventilation and Temperature Controls
 3. Telephone Service
 4. Water
 5. Sanitary Facilities
 6. Barriers
 7. Enclosures
 8. Protection
 9. Water Control
 10. Cleaning During Construction
 11. Field Sheds
 12. Project Specific Conditions

1.3 ELECTRICITY AND LIGHTING

- A. Connect to existing service, provide branch wiring and distribution boxes located to allow service and lighting by means of construction-type power cords in accordance with NEC Art. 305. All power cords shall be fitted with ground fault breakers.
- B. In the event that night time construction is required provide minimum 30-foot candles of lighting for construction operations.
- C. Existing and permanent lighting may be used during construction. Maintain lighting and routine repairs.
- D. A reasonable amount of electricity will be provided by the Owner provided that, in the Owner's opinion no abuse of its use occurs.

1.4 VENTILATION AND TEMPERATURE CONTROLS

- A. Coordinate use of existing facilities with Owner. Extend and supplement facilities with temporary units as required to maintain specified conditions for construction operations and to protect materials and finishes from damage due to temperature or humidity.
- B. Prior to operation of permanent facilities for temporary purposes, verify that installation is approved for operation, and that filters are in place. Provide and pay for operation, maintenance, final cleaning and adjusting.
- C. Provide ventilation of enclosed areas to cure materials, disperse humidity, and prevent accumulations of dust, mold, fumes, vapors and gases.

1.5 TELEPHONE SERVICES

The Contractor will not be allowed to use Owner's telephones. The Contractor may, at his option, provide a land-based telephone at the project site. The project Superintendent shall be required to have in his possession at all times a functioning mobile telephone. The telephone shall be operative at all times and shall be answered by the Superintendent. All number(s) including a 24-hour emergency number shall be provided to the Owner and Architect.

1.6 WATER CONTROL

- A. Connect to existing facilities. Extend branch piping with outlets located so water is available for use with hoses. Place a control device on each hose in order that water will not run freely and be wasted when left on. Patch all holes in hoses, lines, fittings, etc., and maintain in serviceable condition throughout the project.
- B. A reasonable amount of water will be provided by the Owner provided that, in the Owner's opinion, no abuse of its use occurs.

1.7 SANITARY FACILITIES

Portable toilets shall be provided by the Contractor for use during the Work. Portable toilets shall be kept locked at all times and maintained in a sanitary condition, at a location on the site approved by the Architect and Owner. The Contractor's personnel shall not use facilities inside the existing building.

1.8 BARRIERS

- A. Provide as required to prevent public entry to construction areas, to provide for Owner's use of site, and to protect existing facilities and adjacent properties from damage by construction operations.
- B. Provide barriers around trees and plants in affected areas. Protect against vehicular traffic, stored materials, dumping, chemically injurious materials, and puddling or continuous running water.
- C. Provide six (6) foot high chain link fencing around all ground operations where hazardous materials or equipment are in operation. Containment area gates shall have padlocks with the combination or key provided to the Owner.

1.9 ENCLOSURES

- A. Provide temporary weather-tight enclosures of openings in exterior surfaces to provide acceptable working conditions and protection for materials, to allow for temporary heating, and to prevent entry of unauthorized persons. Provide doors with self-closing hardware and locks.
- B. Provide temporary partitions and ceilings as required to separate Work areas from Owner occupied spaces, to prevent product contamination penetration, of dust and moisture into Owner occupied areas, and to prevent damage to existing areas and equipment. Construction shall be wood or steel scaffold framing and plywood sheathing with closed joints and sealed edges at intersections with existing surfaces. Provide temporary partitions as required in accordance with provisions of local building codes and the latest edition of the Life Safety Code.

1.10 PROTECTION OF INSTALLED WORK

- A. Provide temporary protection for installed products. Control traffic in immediate area to minimize damage.

- B. Provide protective covering for walls, projections, jambs, sills, and soffits of openings. Protect finished floors and stairs from traffic, movement of heavy objects and storage.
- C. Prohibit traffic and storage on waterproofed and roofed surfaces and on lawn and landscaped areas not previously identified by Owner for those purposes.

1.11 CLEANING DURING CONSTRUCTION

Control accumulation of waste, debris and rubbish on a daily basis and dispose of off the site. Clean interior areas prior to start of any finish Work and maintain all areas free of contamination.

1.12 FIELD SHEDS

Storage sheds for tools, materials and equipment, if provided, shall be weathertight with heat and ventilation for products requiring same.

1.13 REMOVAL

- A. Remove temporary materials, equipment, services and construction prior to Substantial Completion inspection.
- B. Clean and repair damage caused by installation or use of temporary facilities. Restore existing construction to specified or original condition.
- C. All grounds shall be restored to a like-original condition. If the grounds contain Bermuda grass, seeding is permitted. If the grounds contain St. Augustine grass, it shall be re-sodded. All seeding and re-sodding operations and procedures shall be submitted in writing and be approved by the Architect prior to the Work beginning. Any trees, shrubs or other plantings shall be restored or replaced to their existing condition prior to the Work.

1.14 PROJECT SPECIFIC CONDITIONS

- A. The chain link fence(s) at the staging area(s) shall be erected and maintained where shown on the Drawings and as otherwise occur for the entire course of construction in that location.
- B. A photographic or videotape survey shall be conducted of the interior and exterior of the building prior to any Work beginning. The survey shall be conducted in the presence of the Owner's or Architect's designated representative. Copies of the survey shall be submitted to the Architect within three (3) days of its creation. Failure to provide the survey shall result in the Contractor being held responsible for any and all damages observed thereafter which can reasonably be associated with the Work. The survey shall include the following:
 - 1. All ceiling and floor surfaces throughout the interior of the building. The Contractor shall comply with the Owner's restrictions where building contents are sensitive to light exposure.
 - 2. All sidewalks and paved surfaces outside the building.
 - 3. All current staining of any and all surfaces observed inside or outside the building.
 - 4. All plant life and grounds surrounding the building.

PART 2 - PRODUCTS (Not Used)

PART 3 - EXECUTION (Not Used)

END OF SECTION 01 5000

SECTION 01 6100 - PRODUCT REQUIREMENTS

PART 1 - GENERAL

1.1 RELATED DOCUMENTS

- A. Drawings and general provisions of the Contract, including General and Supplementary Conditions and other Division 01 Specification Sections, apply to this Section.

1.2 SUMMARY

- A. This Section includes:
 1. Products
 2. Transportation
 3. Storage and Protection
 4. Product Options
 5. Products List
 6. Substitutions
 7. Systems Demonstration

1.3 PRODUCTS AND CERTIFICATIONS

- A. Products include material, equipment and systems.
- B. Comply with Specifications and referenced standards as minimum requirements.
- C. Components required to be supplied in quantity within a Specification Section shall be the same, and shall be interchangeable. Components and products within a Specification Section shall be from one manufacturer unless otherwise specified.
- D. Do not use materials and equipment removed from existing structure, except as specifically required or allowed by the Contract Documents.
- E. Submit an asbestos-free certification for all materials proposed for use in the project stating that no material proposed or intended for use contains asbestos. At project completion submit a certificate indicating that all materials installed in the project were asbestos free.

1.4 TRANSPORTATION AND HANDLING

- A. Transport products by methods to avoid damage. Deliver in undamaged condition in manufacturer's unopened dry containers or packaging.
- B. Provide equipment and personnel to handle products by methods to prevent soiling or damage.
- C. Promptly inspect shipments to assure that products comply with requirements, quantities are correct, and products are undamaged.

1.5 STORAGE AND PROTECTION

- A. Store products in accordance with manufacturer's instructions, with seals and labels intact and legible. Store sensitive products in weather tight enclosures; maintain within temperature and humidity ranges required by manufacturer's instructions.
- B. For exterior storage of fabricated products, place on sloped supports above ground. Cover

products subject to deterioration with impervious sheet covering providing ventilation and any required heating to avoid condensation.

- C. Store loose granular materials on solid surfaces in well-drained areas. Prevent mixing with foreign matter.
- D. Arrange storage to provide access for inspection. Periodically inspect to assure products are undamaged and maintained under required conditions.

1.6 PRODUCT OPTIONS

- A. Only within ten (10) days after date established in the Notice to Proceed will Owner consider requests from the Contractor for substitutions. Subsequently, substitutions will be considered only when a product becomes unavailable due to no fault of the Contractor.
- B. Products specified by "Reference Standards" or by "Description Only" shall be any product meeting those standards.
- C. For products specified by naming one or more manufacturers with a provision for substitutions, submit a fully executed Request for Substitution form for any manufacturer not specifically named.
- D. No options or substitutions will be allowed where products are specified by naming of several manufacturers or when proposed substitution products do not exactly meet requirements of these Specifications.

1.7 SYSTEMS DEMONSTRATION

- A. Prior to final inspection, demonstrate operation of each system to all parties concerned.
- B. Instruct Owner's personnel in maintenance of new roof system or modified mechanical items, etc.

PART 2 - PRODUCTS (Not Used)

PART 3 - EXECUTION (Not Used)

END OF SECTION 01 6100

SECTION 01 7329 - CUTTING AND PATCHING

PART 1 - GENERAL

1.1 RELATED DOCUMENTS

- A. Drawings and general provisions of the Contract, including General and Supplementary Conditions and other Division 01 Specification Sections, apply to this Section.

1.2 SUMMARY

- A. This Section includes procedural requirements for cutting and patching.

1.3 DEFINITIONS

- A. Cutting: Removal of in-place construction necessary to permit installation or performance of other Work.
- B. Patching: Fitting and repair work required to restore surfaces to original conditions after installation of other Work.

1.4 SUBMITTALS

- A. Submit written request in advance of cutting or alteration which affects:
 - 1. Structural integrity of any element of Project.
 - 2. Integrity of weather-exposed or moisture-resistant element.
 - 3. Efficiency, maintenance, or safety of any operational equipment.
 - 4. Visual qualities of sight-exposed elements.
 - 5. Work of Owner or separate contractor.
- B. Include in request:
 - 1. Identification of Project.
 - 2. Location and description of affected Work.
 - 3. Necessity for cutting or alteration.
 - 4. Description of proposed Work, and products to be used.
 - a. Scope of cutting, patching, alteration, or excavation.
 - b. Trades who will execute the Work.
 - c. Products proposed to be used.
 - d. Extent of re-finishing.
 - e. Cost proposal, only when applicable.
 - f. Suggested alternatives to cutting and patching.
 - 5. Effect on Work of Owner or separate contractor, if any
 - 6. Written permission of affected separate contractor, if any.
 - 7. Date and time Work will be executed.

1.5 QUALITY ASSURANCE

Requirements for Structural Work: Do not cut or alter any structural Work in a manner that would result in a reduction of load-carrying capacity or of load-deflection ratio.

PART 2 - PRODUCTS

2.1 MATERIALS

- A. Except as otherwise indicated, or as directed by the Owner, use materials for cutting and patching that are identical to existing materials. If identical materials are not available, or cannot be used, use materials that match existing adjacent surfaces to the fullest extent possible with regard to visual effect.
- B. Use materials for cutting and patching that will result in equal-or-better performance characteristics.

PART 3 - EXECUTION

3.1 GENERAL

- A. Execute cutting, fitting and patching, including excavation and fill, to complete Work and to:
 - 1. Fit the several parts together, to integrate with other Work.
 - 2. Uncover Work to install ill-timed Work.
 - 3. Remove and replace defective and non-conforming Work.
 - 4. Remove samples of installed Work for testing.
 - 5. Provide openings in elements of Work for penetrations of mechanical and electrical Work.

3.2 INSPECTION

- A. Before cutting, examine the surfaces to be cut and patched and the conditions under which the Work is to be performed. If unsafe or otherwise unsatisfactory conditions are encountered, take corrective action before proceeding with the Work.
- B. Inspect existing conditions, including elements subject to damage or movement during cutting and patching.
- C. After uncovering, inspect conditions affecting performance of Work.
- D. Beginning of cutting or patching means acceptance of existing conditions.

3.3 PREPARATION

- A. Provide supports to assure structural integrity of surroundings, devices and methods to protect other portions of Work from damage.
- B. Provide protection from elements for areas which may be exposed by uncovering Work; maintain excavations and openings free of water.
- C. Prevent debris from entering facility; do not permit product contamination.

3.4 PERFORMANCE

- A. Employ skilled workers to perform cutting and patching Work. Except as otherwise indicated or as approved by the Architect, proceed with cutting and patching at the earliest feasible time and complete without delay.
- B. Cut the Work using methods that are least likely to damage Work to be retained or adjoining Work. Where possible review proposed procedures with the original installer and comply with its recommendations.
- C. In general, where cutting is required use hand or small power tools designed for sawing or

grinding, not hammering and chopping. Cut through concrete and masonry using a cutting machine, such as a silicon carbide (carborundum) saw or core drill, to ensure a neat hole. Cut holes and slots neatly to size required, with a minimum disturbance of adjacent Work. To avoid marring existing finished surfaces, cut or drill from the exposed or finished side into concealed surfaces. Temporarily cover openings when not used.

- D. Patch with seams which are durable and as invisible as possible. Comply with specified tolerances for the Work. Where feasible, inspect and test patched areas to demonstrate integrity of Work. Restore exposed finishes of patched areas and where necessary extend finish restoration into retained adjoining Work in a manner which will eliminate evidence of patching and re-finishing.
- E. Where removal of walls or partitions extends from one finished area into another finished area, patch and repair floor and wall surfaces in the new space to provide an even surface of uniform color and appearance. If necessary to achieve uniform color and appearance, remove existing floor and wall covering and replace with new materials.
- F. Where patch occurs in a smooth painted surface, extend final paint coat over entire unbroken surface containing patch, after patched area has received prime and base coat. Patch, repair or re-hang existing ceilings as necessary to provide an even plane surface of uniform appearance.
- G. Fit Work airtight to pipes, sleeves, ducts, conduit, and other penetrations through roof, wall, floor or other surfaces.
- H. At penetrations of fire-rated wall, ceiling, or floor construction, completely seal voids with fire rated material for the full thickness of the construction element.
- I. Do not leave facility open to contamination or the elements; close off at end of each work day.
- J. Thoroughly clean areas and spaces where Work is performed or used as access to Work. Remove completely paint, mortar, oils, putty and items of similar nature. Thoroughly clean piping, conduit and similar features before painting or other finishing is applied.

END OF SECTION 01 7329

SECTION 01 7800 - CONTRACT CLOSEOUT

PART 1 - GENERAL

1.1 RELATED DOCUMENTS

- A. Drawings and general provisions of the Contract, including General and Supplementary Conditions and other Division 01 Specification Sections, apply to this Section.

1.2 SUMMARY

- A. Section includes administrative and procedural requirements for contract closeout, including, but not limited to, the following:
1. Substantial Completion procedures.
 2. Final completion procedures.
 3. Warranties.
 4. Final cleaning.
 5. Repair of the Work.

1.3 SUBSTANTIAL COMPLETION PROCEDURES

- A. Preliminary Procedures: Before requesting inspection for determining date of Substantial Completion, complete the following. List items below that are incomplete in request.
1. Prepare a list of items to be completed and corrected (punch list), the value of items on the list, and reasons why the Work is not complete.
 2. Advise Owner of pending insurance changeover requirements.
 3. Submit specific warranties, workmanship bonds, maintenance service agreements, final certifications, and similar documents.
 4. Obtain and submit releases permitting Owner unrestricted use of the Work and access to services and utilities. Include occupancy permits, operating certificates, and similar releases.
 5. Prepare and submit Project Record Documents, operation and maintenance manuals.
 6. Deliver tools, spare parts, extra materials, and similar items to location designated by Owner. Label with manufacturer's name and model number where applicable.
 7. Make final changeover of permanent locks and deliver keys to Owner. Advise Owner's personnel of changeover in security provisions.
 8. Terminate and remove temporary facilities from Project site, along with mockups, construction tools, and similar elements.
 9. Submit changeover information related to Owner's occupancy, use, operation, and maintenance.
 10. Complete final cleaning requirements, including touchup painting.
 11. Touch up and otherwise repair and restore marred exposed finishes to eliminate visual defects.
- B. Inspection: Submit a written request for inspection to determine Substantial Completion. On receipt of request, Architect will either proceed with inspection or notify Contractor of unfulfilled requirements. Architect will prepare the Certificate of Substantial Completion after inspection or will notify Contractor of items, either on Contractor's list or additional items identified by Architect, that must be completed or corrected before certificate will be issued.
1. Re-inspection: Request re-inspection when the Work identified in previous inspections as incomplete is completed or corrected.
 2. Results of completed inspection will form the basis of requirements for final completion.

1.4 FINAL COMPLETION PROCEDURES

- A. Before requesting final inspection for determining final completion, complete the following:
 - 1. Submit a final Application for Payment.
 - 2. Submit certified copy of Architect's Substantial Completion inspection list of items to be completed or corrected (punch list), endorsed and dated by Architect. Certified copy of the list shall state that each item has been completed or otherwise resolved for acceptance.
 - 3. Submit evidence of final, continuing insurance coverage complying with insurance requirements.
- B. Inspection: Submit a written request for final inspections. On receipt of request, Architect will either proceed with inspection or notify Contractor of unfulfilled requirements. Architect will prepare a final Certificate for Payment after inspection or will notify Contractor of construction that must be completed or corrected before certificate will be issued.
 - 1. Re-inspection: Request re-inspection when the Work identified in previous inspections as incomplete is completed or corrected.

1.5 SUBMITTAL OF PROJECT WARRANTIES

- A. Time of Submittal: Submit written warranties on request of Architect for designated portions of the Work where commencement of warranties other than date of Substantial Completion is indicated.
- B. Organize warranty documents into an orderly sequence based on the table of contents of Project Manual.
 - 1. Bind warranties and bonds in heavy-duty, three-ring, vinyl-covered, loose-leaf binders, thickness as necessary to accommodate contents, and sized to receive 8-1/2-by-11-inch paper.
 - 2. Provide heavy paper dividers with plastic-covered tabs for each separate warranty. Mark tab to identify the product or installation. Provide a typed description of the product or installation, including the name of the product and the name, address, and telephone number of Installer.
 - 3. Identify each binder on the front and spine with the typed or printed title "WARRANTIES," Project name, and name of Contractor.
 - 4. Warranty Electronic File: Scan warranties and bonds and assemble complete warranty and bond submittal package into a single indexed electronic PDF file with links enabling navigation to each item. Provide bookmarked table of contents at beginning of document.
- C. Provide additional copies of each warranty to include in operation and maintenance manuals.

PART 2 - PRODUCTS

2.1 MATERIALS

- A. Cleaning Agents: Use cleaning materials and agents recommended by manufacturer or fabricator of the surface to be cleaned. Do not use cleaning agents that are potentially hazardous to health or property or that might damage finished surfaces.

2.2 CLOSEOUT DOCUMENTS

- A. Prior to requesting a review of the fully completed punch list items submit the following documents to the Architect:
1. Final Application and Certificate of Payment. Include back-up sheets showing all items to be 100% complete.
 2. Letter stating that all items of Work are complete, along with a "punch list" of any exceptions.
 3. Contractor's Affidavit of Bills Paid. (*AIA Document G706*)
 4. Contractor's Affidavit of Release of Lien. (*AIA Document G706A*)
 5. Consent of Surety to Final Payment.
 6. Two-year Warranty for Roofing per Section 01 7830.
 7. One-year Warranty from Window, Painting, Mechanical, Plumbing, Electrical and any other applicable subcontractor.
 8. Twenty-year manufacturer's warranty for the single ply roof system.
 9. Twenty-year pre-finished metal warranty.
 10. All warranties shall be dated no earlier than the Date of Substantial Completion.
- B. Organize warranty documents into an orderly sequence based on the table of contents of Project Manual. Provide three (3) copies of all required closeout documents submitted in three (3) separate binders as described below.
1. Bind documents in heavy-duty, three-ring, vinyl-covered, loose-leaf binders, thickness as necessary to accommodate contents, and sized to receive 8-1/2-by-11-inch paper.
 2. Provide heavy paper dividers with plastic-covered tabs for each separate warranty. Mark tab to identify the product or installation. Provide a typed description of the product or installation, including the name of the product and the name, address, and telephone number of Installer.
 3. Identify each binder on the front and spine with the typed or printed title "CLOSEOUT DOCUMENTS," Project name, and name of Contractor.

2.3 RECORD DOCUMENT SUBMITTALS

- A. Specific requirements for Record Documents are indicated in individual sections of these Specifications. Other requirements are indicated in General Conditions. General submittal requirements are indicated in Section 01 3300. Do not use Record Documents for construction purposes; protect from deterioration and loss in a secure, fire-resistive location; and provide access to Record Documents for Architect's reference during normal Work hours.
- B. Record Documents:
1. Maintain a blue-line or black-line print of Contract Documents and shop drawings in clean, undamaged condition, with mark-up of actual installations which vary substantially from the Work as shown.
 - a. Mark whichever drawing is most capable of showing "field" conditions fully and accurately; however, where shop drawings are used for mark-up, record a cross-reference at corresponding location on working drawings.
 - b. Mark with red erasable pencil and, where feasible, use other colors to distinguish between variations in separate categories of Work.
 - c. Mark-up new information which is recognized to be of importance to the Owner, but was for some reason not shown on either the contract drawings or shop drawings.
 - d. Give particular attention to concealed Work, which would be difficult to measure and record at a later date. Note related change order numbers where applicable.
 2. Organize record drawing sheets into manageable sets, bind with durable paper cover sheets, and print suitable titles, dates and other identification on cover of each set.
 3. Upon completion of preparation of the as-built set have it reproduced and submit one (1) set along with two blue-line copies to the Architect.

- C. Maintain one copy of Specifications, including all addenda, change orders and similar modifications issued in printed form during construction, and mark-up variations (of substance) in actual Work in comparison with text of Specifications and modifications as issued.
 - 1. Give particular attention to substitutions, selection of options, and similar information on Work where it is concealed or cannot otherwise be readily discerned at a later date by direct observation.
 - 2. Note related record drawing information and product data, where applicable.
 - 3. Upon completion of mark-up, submit to Architect for Owner's records.
- D. Operations and Maintenance Manual: Provide Record Drawings and Specifications, warranty and maintenance instructions bound in book form for the Owner upon project completion. Provide three (3) copies of each.

PART 3 - EXECUTION

3.1 FINAL CLEANING

- A. General: Perform final cleaning. Conduct cleaning and waste-removal operations to comply with local laws and ordinances and Federal and local environmental and antipollution regulations.
- B. Cleaning: Employ experienced workers or professional cleaners for final cleaning. Clean each surface or unit to condition expected in an average commercial building cleaning and maintenance program. Comply with manufacturer's written instructions.
 - 1. Complete the following cleaning operations before requesting inspection for certification of Substantial Completion for entire Project or for a designated portion of Project:
 - a. Clean Project site, yard, and grounds, in areas disturbed by construction activities, including landscape development areas, of rubbish, waste material, litter, and other foreign substances.
 - b. Sweep paved areas broom clean. Remove petrochemical spills, stains, and other foreign deposits.
 - c. Rake grounds that are neither planted nor paved to a smooth, even-textured surface.
 - d. Remove tools, construction equipment, machinery, and surplus material from Project site.
 - e. Clean exposed exterior and interior hard-surfaced finishes to a dirt-free condition, free of stains, films, and similar foreign substances. Avoid disturbing natural weathering of exterior surfaces. Restore reflective surfaces to their original condition.
 - f. Remove debris and surface dust from limited access spaces, including roofs, plenums, shafts, trenches, equipment vaults, manholes, attics, and similar spaces.
 - g. Sweep concrete floors broom clean in unoccupied spaces.
 - h. Vacuum carpet and similar soft surfaces, removing debris and excess nap; clean according to manufacturer's recommendations if visible soil or stains remain.
 - i. Clean transparent materials, including mirrors and glass in doors and windows. Remove glazing compounds and other noticeable, vision-obscuring materials. Polish mirrors and glass, taking care not to scratch surfaces.
 - j. Remove labels that are not permanent.
 - k. Wipe surfaces of mechanical and electrical equipment and similar equipment. Remove excess lubrication, paint and mortar droppings, and other foreign substances.
 - l. Clean plumbing fixtures to a sanitary condition, free of stains, including stains resulting from water exposure.
 - m. Leave Project clean and ready for occupancy.

3.2 REPAIR OF THE WORK

- A. Complete repair and restoration operations before requesting inspection for determination of Substantial Completion.

- B. Repair or remove and replace defective construction. Repairing includes replacing defective parts, refinishing damaged surfaces, touching up with matching materials, and properly adjusting operating equipment. Where damaged or worn items cannot be repaired or restored, provide replacements. Remove and replace operating components that cannot be repaired. Restore damaged construction and permanent facilities used during construction to specified condition.
 - 1. Touch up and otherwise repair and restore marred or exposed finishes and surfaces. Replace finishes and surfaces that that already show evidence of repair or restoration.
 - a. Do not paint over "UL" and other required labels and identification, including mechanical and electrical nameplates. Remove paint applied to required labels and identification.
 - 2. Replace parts subject to operating conditions during construction that may impede operation or reduce longevity.

END OF SECTION 01 7800

SECTION 01 7830 - ROOFING INSTALLER'S WARRANTY

WHEREAS _____,

of _____,

Herein called the "Contractor," has performed roofing and associated Work on the following project:

Roof Replacement – Houston Elementary School
5409 Ponciana Dr., Austin, TX 78744
AISD Project No. 18-0023-HOUST

Owner: **AUSTIN INDEPENDENT SCHOOL DISTRICT**
Address: 812 San Antonio Street, Suite 200, Austin, Texas 78701

Area(s) of Work _____

Acceptance Date: _____ Warranty Period: **Two (2) Years**

Date of Expiration: _____

AND WHEREAS the Contractor has contracted with Owner to warrant said Work against leaks and faulty or defective materials and workmanship for designated Warranty Period.

NOW THEREFORE the Contractor hereby warrants, subject to terms and conditions herein set forth, that during Warranty Period will at its own cost and expense, make or cause to be made such repairs to, or replacement of said Work as is necessary to correct faulty and defective Work, and as is necessary to maintain said Work in watertight condition.

This Warranty is made subject to the following terms and conditions:

1. Specifically excluded from this Warranty are damages to Work and other parts of the building, and to building contents, caused by: (a) lightning, windstorm, and other unusual phenomena of the elements; (b) fire; (c) failure of roofing system substrate including cracking, settlement, excessive deflection, deterioration, and decomposition; (d) faulty construction of vents, mechanical equipment, and other penetrations not installed as part of the Work; (e) repeated vapor condensation on bottom of roofing; and (f) activity on roofing by other persons including construction contractors and maintenance personnel, whether authorized or unauthorized by Owner.
2. When Work has been damaged by any of the foregoing causes, Warranty shall be null and void until such damage has been repaired by the Contractor, and until cost and expense thereof has been paid for by the Owner, or by another responsible party so designated.
3. The Contractor is responsible for Work covered by this Warranty, but is not liable for consequential damages to buildings or building contents resulting from leaks or faults or defects of the Work.
4. During Warranty Period, if the Owner allows alterations of Work by anyone other than the Contractor, including cutting, patching and maintenance in connection with penetrations, attachment of other Work, and positioning of anything on roof, this Warranty shall become null and void upon date of said alterations, but only to extent said alterations affect Work covered by this Warranty. If the Owner engages the Contractor to perform said alterations, Warranty shall not become null and void, unless the Contractor, before starting said Work, shall have notified the Owner in writing, showing reasonable cause for claim, that said alterations

would likely damage or deteriorate the Work, thereby reasonably justifying a limitation or termination of this Warranty.

5. During Warranty Period, if original use of roof is changed and it becomes used for, but was not originally specified for, a promenade, work deck, spray cooled surface, flooded basin, or other use or service more severe than originally specified, this Warranty shall become null and void upon date of said change, but only to extent said changes affect Work covered by this Warranty.

6. Owner shall promptly notify the Contractor of observed, known, or suspected leaks, defects or deterioration, and shall afford reasonable opportunity for the Contractor to inspect the Work, and to examine evidence of such leaks, defects or deterioration.

7. This Warranty is recognized to be the only Warranty of the Contractor on said Work, and shall not operate to restrict or cut off the Owner from other remedies and resources lawfully available to Owner in cases of roofing failure. Specifically, this Warranty shall not operate to relieve the Contractor of responsibility for performance of original Work.

IN WITNESS THEREOF, this instrument has been duly executed this _____ day of _____, 20____.

Contractor Name and Address

Typed name and Title

Signature

Telephone Number

Fax Number

Notary Seal

SECTION 06 1050 - ROOF CARPENTRY

PART 1 - GENERAL

1.1 RELATED DOCUMENTS

- A. Drawings and general provisions of the Contract, including General and Supplementary Conditions and other Division 01 through Division 26 Specification Sections, apply to this Section.

1.2 SUMMARY

- A. Section Includes:
 - 1. Framing with dimension lumber.
 - 2. Wood blocking and nailers.
 - 3. Wood furring.
 - 4. Isolation tape.
 - 5. Plywood sheathing.
- B. Related Sections
 - 1. Section 07 0151 - Roof Removal Procedures
 - 2. Section 07 5216 - Modified Bitumen Roof System
 - 3. Section 07 6200 - Flashing and Sheet Metal

1.3 DEFINITIONS

- A. Dimension Lumber: Lumber of 2 inches nominal or greater but less than 5 inches nominal in least dimension.
- B. Lumber grading agencies, and the abbreviations used to reference them, include the following:
 - 1. NeLMA: Northeastern Lumber Manufacturers' Association.
 - 2. NHLA: National Hardwood Lumber Association.
 - 3. NLGA: National Lumber Grades Authority.
 - 4. SPIB: The Southern Pine Inspection Bureau.
 - 5. WCLIB: West Coast Lumber Inspection Bureau.
 - 6. WWPAA: Western Wood Products Association.

1.4 REFERENCES

- A. American Lumber Standards Committee (ALSC): National Design Specification for Wood Construction.
- B. American Wood Preservers' Association (AWPA): AWPA Book of Standards.
- C. American Wood Preservers Bureau (AWPB): APA Design Construction Guide.
- D. Product Standard of NBS (PS):
 - 1. PS 1 - Construction and Industrial Plywood.
 - 2. PS 20 - American Softwood Lumber Standard.

1.5 SUBMITTALS

- A. Submit product data and certificates under provisions of the appropriate Division 01 Section for the following:
 - 1. Dimensional treated lumber.

2. CDX plywood.
 - B. Submit product data for all wood fasteners, including their sizes, material, type and finish.
 - C. Product Data: For each type of process and factory-fabricated product. Indicate component materials and dimensions and include construction and application details.
 1. Include data for wood-preservative treatment from chemical treatment manufacturer and certification by treating plant that treated materials comply with requirements. Indicate type of preservative used and net amount of preservative retained.
 2. For products receiving a waterborne treatment, include statement that moisture content of treated materials was reduced to levels specified before shipment to Project site.
 3. Include copies of warranties from chemical treatment manufacturers for each type of treatment.
 - D. Mark each proposed item in product data by circling or highlighting, and affix the corresponding Article and Paragraph designations from this Specification Section. Product data not so marked will be returned without review, for re-submittal complying with the above requirements.
- 1.6 DELIVERY, STORAGE AND HANDLING
- A. Deliver materials in bulk as necessary to provide continuous operations and no Work slow-down. Schedule and coordinate with Owner to cause the least inconvenience to Owner's daily activities. All deliveries and unloading or loading activities are the responsibility of the Contractor. Owner will not take responsibility for any delivery activities.
 - B. Stack lumber flat with spacers beneath and between each bundle to provide air circulation. Protect lumber from weather by covering with waterproof sheeting, securely anchored. Provide for air circulation around stacks and under coverings.
 - C. Store materials in designated areas, out of the way of Owner's on-going operations.
 - D. Store and handle materials to preclude damage and contamination with moisture or foreign matter.

PART 2 - PRODUCTS

2.1 WOOD PRODUCTS, GENERAL

- A. Lumber: DOC PS 20 and applicable rules of grading agencies indicated. If no grading agency is indicated, provide lumber that complies with the applicable rules of any rules-writing agency certified by the ALSC Board of Review. Provide lumber graded by an agency certified by the ALSC Board of Review to inspect and grade lumber under the rules indicated.
 1. Factory mark each piece of lumber with grade stamp of grading agency.
 2. Where nominal sizes are indicated, provide actual sizes required by DOC PS 20 for moisture content specified. Where actual sizes are indicated, they are minimum dressed sizes for dry lumber.
 3. Provide dressed lumber, S4S, unless otherwise indicated.
- B. Maximum Moisture Content of Lumber: 19% at time of dressing unless otherwise indicated.

2.2 WOOD-PRESERVATIVE-TREATED MATERIALS

- A. Preservative Treatment by Pressure Process: AWP A U1.

1. Preservative Chemicals: Acceptable to authorities having jurisdiction and containing no arsenic or chromium.
- B. Kiln-dry lumber after treatment to a maximum moisture content of 19 percent. Do not use material that is warped or does not comply with requirements for untreated material.
- C. Mark lumber with treatment quality mark of an inspection agency approved by the ALSC Board of Review.
- D. Application: Treat all miscellaneous carpentry unless otherwise indicated, items indicated on Drawings, and the following:
 1. Wood cants, nailers, curbs, equipment support bases, blocking, stripping, and similar members in connection with roofing, flashing, vapor barriers, and waterproofing.

2.3 DIMENSION LUMBER FRAMING

- A. Southern Pine;
 1. Two-inch nominal dimension lumber: No. 1 common, stress rated Fb 1350.

2.4 PLYWOOD

- A. DOC PS 1, Exposure 1, C-D Plugged, thickness as shown on drawings. Do not further treat after manufacture.

2.5 FASTENERS

- A. General: Provide fasteners of size and type indicated that comply with requirements specified in this Article for material and manufacture.
 1. Where carpentry is exposed to weather, in ground contact, pressure-preservative treated, or in area of high relative humidity, provide fasteners of Type 304 stainless steel.
- B. Provide fasteners in the sizes and of the type indicated.
 1. Screws, Nails and Small Bolts in Treated Wood: Stainless steel.
 2. Screws and Nails in Non-Treated Wood: Hot-dipped galvanized finish.
 3. ¼-inch and Larger Diameter Bolts: Hot-dip galvanized finish.
- C. Masonry and/or Concrete Substrate Fasteners:
 1. Zamac "Hammer Screw: Steel pin and zinc-jacketed fasteners;" ¼-inch x 1 1/2-inch, or approved equal.
 2. "Tapcon," or approved equal, in sizes and lengths dictated by existing conditions, and approved by the Architect.

2.6 MISCELLANEOUS MATERIALS

- A. Flexible Flashing Separator: Multi-Purposed Grade Duct Tape, with polyethylene-coated cloth backing, natural rubber-based adhesive, and silver in color, as produced by Tyco Adhesives, 3-M Corporation, or an approved equal.
 1. Total Thickness: 11 mils, ASTM D 1000.
 2. Adhesion to Backing: 46 ounce/inch, PSTC-1
 3. Maximum Performance Temperature: 200 Degrees F.

PART 3 - EXECUTION

3.1 INSTALLATION

- A. Set carpentry to required levels and lines, with members plumb, true to line, cut, and fitted. Fit carpentry to other construction; scribe and cope as needed for accurate fit. Locate nailers, blocking, and similar supports to comply with requirements for attaching other construction.
 - 1. Securely attach carpentry Work to substrate by anchoring and fastening as shown and as required by recognized standards.
 - 2. Countersink nail heads on exposed carpentry Work and fill holes.
 - 3. Use common wire nails, except as otherwise indicated.
 - 4. Select fasteners of size that do not penetrate members where opposite sides are exposed to view or will receive finish materials.
 - 5. Make tight connections between members.
 - 6. Pre-drill holes when required to prevent splitting of wood.
 - B. Where wood-preservative-treated lumber is installed adjacent to metal decking, install continuous flexible flashing separator between wood and metal decking.
 - C. Discard units of material with defects which might impair quality of Work, and units which are too small to use in fabricating Work with minimum joints or optimum joint arrangement.
 - D. Provide wood products to size and shape shown and coordinate closely with all other scheduled Work for continuous operation of all trades.
 - E. Install wood nailers at perimeters and flanged penetrations, matching insulation in height.
 - F. When securing wood blocking by nailing:
 - 1. Secure 3/4-inch and 1-inch materials with 8d stainless steel framing nails.
 - 2. Secure 1-1/2 inch or 2-inch materials with 16d stainless steel framing nails.
 - 3. Do not exceed nail spacing 12-inches on centers, or as detailed, and drive nails securely in place. Remove and dispose of bent or deformed nails or fasteners.
 - G. Install perimeter wood nailers with specified fasteners spaced at maximum 24-inches on centers and within 6-inches of the ends of cut pieces, corners and bends.
 - H. Fit carpentry items to other Work. Scribe and cope as required for accurate fit.
 - I. Correlate locations of nailers, blocking, and similar supports to allow proper attachment of other Work necessary.
 - J. Provide additional fasteners in existing perimeter wood blocking as necessary so fastener spacing does not exceed 24-inches on center staggered.
- 3.2 PROTECTION
- A. Protective Walkways: Install full sheets of 1/2-inch plywood over minimum 1-inch insulation board over areas of new roof surface to be trafficked by personnel and wheeled vehicles.
- 3.3 CLEANING
- A. Pick up spilled nails and fasteners from grounds and roof surface continually.

END OF SECTION 06 1050

SECTION 07 0151 - PREPARATION FOR RE-ROOFING

PART 1 - GENERAL

1.1 RELATED DOCUMENTS

- A. Drawings and general provisions of the Contract, including General and Supplementary Conditions and Division 01 through Division 26 Specification Sections, apply to this Section.

1.2 SUMMARY

- A. Section Includes:
 - 1. Roof removal.
 - 2. Deck repair.
- B. Related Sections
 - 1. Section 06 1050 - Roof Carpentry
 - 2. Section 07 5220 - Roofing Installer's Warranty

1.3 MATERIALS OWNERSHIP

- A. Except for items or materials indicated to be reused, reinstalled, or otherwise indicated to remain Owner's property, demolished materials shall become Contractor's property and shall be removed from Project site

1.4 SUBMITTALS

- A. Submit current catalogs/brochures describing products for review, coordination and final approval for use in this Project. Deliver submittals per requirements of appropriate Division 01 Section.
- B. Mark each proposed item in product data by circling or highlighting, and affixing the corresponding article and paragraph numbers from this specification. Product data not so marked will be returned without review, for re-submittal complying with the above requirements.
- C. Photographs or Videotape: Show existing conditions of adjoining construction and site improvements, including exterior and interior finish surfaces, that might be misconstrued as having been damaged by reroofing operations. Submit before Work begins.
- D. Provide a demolition plan indicating at a minimum the following:
 - 1. Schedule of demolition detailed to correspond to re-roofing operations.
 - 2. Requirements of staging including methods proposed for transport of materials from the roof to the ground.
 - 3. Submit containment fence layout, materials and support structure for all rooftop and ground locations.

1.5 PROJECT CONDITIONS

- A. Owner will occupy portions of building immediately below reroofing area. Conduct reroofing so Owner's operations will not be disrupted. Provide Owner with not less than 72 hours' notice of activities that may affect Owner's operations.
 - 1. Coordinate work activities daily with Owner so Owner can place protective dust or water leakage covers over sensitive equipment or furnishings, shut down HVAC and fire-alarm or -detection equipment if needed, and evacuate occupants from below the work area.

2. Before working over structurally impaired areas of deck, notify Owner to evacuate occupants from below the affected area. Verify that occupants below the work area have been evacuated before proceeding with work over the impaired deck area.
- B. Protect building to be reroofed, adjacent buildings, walkways, site improvements, exterior plantings, and landscaping from damage or soiling from reroofing operations.
- C. Maintain access to existing walkways, corridors, and other adjacent occupied or used facilities.
- D. Weather Limitations: Proceed with reroofing preparation only when existing and forecasted weather conditions permit Work to proceed without water entering existing roofing system or building.
- E. Hazardous Materials: It is not expected that hazardous materials such as asbestos-containing materials will be encountered in the Work.
 1. If materials suspected of containing hazardous materials are encountered, do not disturb; immediately notify Architect and Owner.
- F. The allowable weight distribution for all roof areas is 20 pounds per square foot.
 1. All construction materials and demolished materials shall be stored on the roof in a neat and organized manner, and shall not exceed 20 psf. All demolished materials shall be secured and covered on a daily basis.
 2. Remove demolished materials and place new construction materials on the roof by way of crane lifting. Crane lifts shall be coordinated with the owners designated representative and shall only occur at times acceptable to the owner. Unless otherwise approved, all crane lifts shall occur on Saturdays.
 3. Transfer demolished materials directly from the roof into ground-based trash containers and remove the trash containers immediately. Trash containers shall be delivered and removed on the same day only. No container may be stored on the owner's property overnight.
 4. Take precautions to prevent damage to surfaces by ground-based disposal containers.
 5. The owner's designated representative will identify a remote laydown area where the contractor may stage materials. The contractor shall supply temporary fencing and/or conex boxes for all materials placed in the remote laydown areas. The contractor is responsible for the security of the laydown area. Materials may only be moved from the laydown area to the crane lift staging area on the day of the crane lift.
- G. In the event of the discovery of unanticipated substrates, or damaged or deteriorated structural components, immediately advise the Architect and await instructions prior to proceeding, unless otherwise directed. Repair and/or replace damaged or deteriorated decking in strict compliance with this Section, or as otherwise directed by the Architect.
- H. Perform pull tests on decking immediately upon completion of roofing demolition.
 1. Provide at the site for the duration of the demolition Work a calibrated, crank style pull tester for performing pull tests when directed by the Architect.
 2. Pull test locations shall be noted on the as-built drawings with a log of locations and results provided to the Architect.
 3. Minimum pull strengths in metal decking shall achieve 250 lbs., or the decking shall be removed and replaced.
 4. A minimum of two (2) pull tests shall be performed for every 1,000 square feet of decking.
- I. Coordinate with Owner to shut down air-intake equipment in the vicinity of the Work. Cover air-intake louvers before proceeding with reroofing work that could affect indoor air quality or activate smoke detectors in the ductwork.

- J. The contractor shall supply, erect, and maintain a temporary access stair from the ground level to the roof. The contractor may not use ladders or the building's interior stairwells to access the roof without authorization from the owner. The temporary access stair shall be constructed to all applicable safety standards and shall be inspected by the contractor prior to use each day. The contractor shall provide security fencing a least 6' in height that completely encloses the base of the stair and shall secure the stair at the end of the work day to prevent unauthorized access to the roof.

PART 2 - PRODUCTS

2.1 STEEL DECKING REPAIR OR REPLACEMENT

- A. Steel Decking: 22-gauge galvanized decking. Profile shall match existing.
- B. Deck Fasteners Screws: #12 self-drilling galvanized steel TEK 5 screws, 1.5 inch in length.
- C. Stitch Screws: #10 self-tapping galvanized steel sheet metal screws, 0.75 inch in length.

PART 3 - EXECUTION

3.1 PREPARATION/DEMOLITION

- A. Completely remove all existing roofing materials and flashings to the existing decking over the entirety of the roof areas indicated by the Drawings. Replace or repair any decking so damaged that it is unable to hold new fasteners.
- B. Remove and properly dispose of existing roofing, insulation, flashings, unused accessories and other items as detailed on all areas shown. Coordinate all activities with Owner.
- C. Control dust as much as possible by lightly sprinkling the roof surface with clean water. Police the roof and grounds constantly to prevent debris blowing off the roof and around the site.
- D. Adhere to the following removal procedures, without deviation:
 - 1. Transport debris to the disposal vehicle/dumpster using a fully enclosed trash chute. The chute shall be designed to deposit debris a maximum distance of 12 inches above the sides of the container.
 - 2. Do not stack debris above the top edge of the container.
 - 3. Prior to removing the container from the site, cover it with a tarp and contain it so that no debris escapes during transport to the dump site.
 - 4. Cranes with fully enclosed buckets may be used for transport of materials from roof level.
 - 5. When in the Contractor's opinion high winds would be hazardous to the health and safety of its employees, or when debris cannot be controlled in conducting tear-off operations, suspend work and return the roof to a watertight condition.
- E. Leave the substrate completely free of debris or foreign matter. Inspect decks at this time. Where deteriorated conditions are found, report findings to Architect in writing for direction.
- F. Bring accessories which the Contractor may deem no longer necessary to the attention of the Architect.
 - 1. Do not start removal and deck repair procedures until authorization is obtained from the Architect.
 - 2. Any and all removed accessories are to be considered the property of the Owner, who reserves the right to retain possession.
 - 3. Equipment and/or any materials removed, not used, and not claimed by the Owner, shall be

removed and properly disposed of off site.

3.2 DECK REPAIR OR REPLACEMENT

- A. Metal Deck Removal and Replacement. The following procedures shall be followed:
1. Where possible, the Architect shall be notified a minimum of 48-hours (weekdays only) in advance of the Contractor's intended deck replacement Work.
 2. Following removal of the built-up roofing and insulation the Contractor shall broom and completely clean the deck and flutes of all debris, dust, etc.
 3. All welds shall be ground loose and the deck removed in sections. The use of cutting torches is prohibited. Caution shall be exercised to not damage the bar joists or other steel structural members during deck removal.
 4. Metal decking shall be moved from the roof to the storage or demolition area on the day it is removed. Stocking of removed panels on the roof surface overnight is prohibited. Deck panels shall be removed to the ground by controlled lift or crane.
 5. The top chords of each bar joist shall be inspected and repaired as required. Existing welds shall be ground smooth and flush with the top chord so as to prevent conflicts with the new decking. All ground surfaces shall be primed with one coat of red oxide primer.
 6. Lay metal deck panels perpendicular to the existing bar joists and fastened along each joist with specified TEK screws spaced at 6 inches on centers. Fully seat side laps in adjacent deck panels or set within 0.25-inch of other side stops. End laps shall be handled as shown in the manufacturer's shop drawings. End laps shall occur over existing bar joists only. Side laps shall be fastened with stitch screws spaced at 12 inches on centers.
 7. Installation of new insulation shall not occur until all decking is in place and has been observed by the Architect's representative.
 8. Debris dropped below the deck shall be removed in its entirety. Any damaged materials below the deck, occurring as a part of this Work, shall be remedied to the Owner's and Architect's satisfaction.
- B. Small Deck Repair MDR-1, **(Unit Price No. 4)**:
1. Hole repairs do not require prior notification to the Architect and may occur while classes are in session.
 2. Holes through deck measuring less than 12-inches in diameter or sides shall be repaired by attaching one layer of 10-gauge galvanized metal with insulation screws spaced at 6 inches on centers, maximum.
 3. The new repair metal shall lap over the existing decking by a minimum of 6 inches on all sides of the hole.
- C. Metal Deck Repair MDR-2 - Large Sheet Replacement, **(Unit Price No. 5)**:
1. New metal decking shall match the existing profile.
 2. Sheet replacement shall cover a minimum of two spans.
 3. New decking shall extend a minimum of 6 inches over each end joist with the entire width of the sheets being replaced.
 4. New decking shall be fastened with specified screws spaced at 6 inches on centers along each bar joist.
 5. All laps shall have sheet metal stitch screws spaced at 12 inches on centers.
- D. Metal Deck Repair MDR-3 - Surface Rust Remediation, **(Unit Price No. 6)**:
1. Remove all rust by wire brushing and apply rust bonding red oxide metal primer.

3.3 CLEANING

Broom clean all walks, drives and other surfaces on a daily basis. Promptly pick up and dispose of all debris outside the containment fencing.

3.4 RECORDS

Accurately record all structural element repairs on the Project Record Documents (“as-built” drawings).

END OF SECTION 07 0151

SECTION 07 2200 - ROOF INSULATION

PART 1 - GENERAL

1.1 RELATED DOCUMENTS

- A. Drawings and general provisions of the Contract, including General and Supplementary Conditions and other Division 01 through Division 26 Specification Sections, apply to this Section.

1.2 SUMMARY

- A. Section Includes:
 - 1. Polyisocyanurate board insulation.
 - 2. Gypsum cover board.
 - 3. Insulation adhesive.
 - 4. Fiber cant strips.
- B. Related Sections
 - 1. Section 06 1050 - Roof Carpentry
 - 2. Section 07 5216 - Modified Bitumen Roof System
 - 3. Section 07 5220 - Roofing Installer's Warranty
 - 4. Section 07 6200 - Flashing and Sheet Metal

1.3 SUBMITTALS

- A. Product List: Submit list of proposed Products and manufacturers, including all items specified in Part 2 – Products or otherwise required by the Work.
- B. Product Data: For each type of process and factory-fabricated product. Indicate component materials and dimensions and include construction and application details.
- C. Mark each proposed item in product data by circling or highlighting, and affix the corresponding Article and Paragraph designations from this Specification Section. Product data no so marked will be returned without review, for re-submittal complying with the above requirements.
- D. Shop Drawings:
 - 1. Tapered insulation, including slopes.
 - 2. Crickets, saddles, and tapered edge strips, including slopes.
 - 3. Insulation fastening patterns for corner, perimeter, and field-of-roof locations.
- E. Submit specified manufacturer's letters and certificates.

1.4 DELIVERY, STORAGE, AND HANDLING

- A. Deliver roofing materials to Project site in original containers with seals unbroken and labeled with manufacturer's name, product brand name and type, date of manufacture, approval or listing agency markings, and directions for storing and mixing with other components.
 - 1. Inspect for damage.
 - 2. Store products in weather protected environment, clear of ground and moisture.
 - 3. Deliver materials in quantities to allow continuity of application throughout the Project.
 - 4. Coordinate shipment receipt as necessary to cause Owner least amount of interference in Owner's operations. Owner will not take responsibility for product deliveries.

- B. Store liquid materials in their original undamaged containers in a clean, dry, protected location and within the temperature range required by roofing system manufacturer. Protect stored liquid material from direct sunlight.
 - 1. Discard and legally dispose of liquid material that cannot be applied within its stated shelf life
- C. Protect roof insulation materials from physical damage and from deterioration by sunlight, moisture, soiling, and other sources.
 - 1. Store materials subject to water damage in fully enclosed, watertight storage trailers.
 - 2. Do not store insulation materials on the roof overnight.
 - 3. Store materials on the roof surfaces only on the morning they will be installed. Do not store more materials on roof overnight unless approved by the Architect.
 - 4. Maximum Allowable Loading on Roof: 20 pounds per square foot.
- D. Handle materials in a manner precluding damage and contamination by moisture or other harmful/foreign matter.
- E. Promptly mark, remove from the site, and discard any materials contaminated by moisture.

1.5 PERFORMANCE REQUIREMENTS

- A. General Performance: Provide installed insulation and/or base sheet that withstand specified uplift pressures, thermally induced movement, and exposure to weather without failure due to defective manufacture, fabrication, installation, or other defects in construction. Membrane roofing and base flashings shall remain watertight.
- B. Material Compatibility: Provide roofing materials that are compatible with one another under conditions of service and application required, as demonstrated by membrane roofing manufacturer based on testing and field experience.
- C. Roof System Design: Provide a roofing system that meets or exceeds the more stringent of the following designations:
 - 1. Provide a roofing system that is identical to systems that have been successfully tested by a qualified testing and inspecting agency to resist wind uplift pressures calculated according to ASCE 7.
 - 2. Wind Uplift Resistance Values: A minimum of two (2.0) times these wind uplift pressures.
- D. Approval Standards: Meet testing standards of FM 4450 and FM 4470.

1.6 JOB CONDITIONS

- A. Do not apply any portion of the roof system or its accessories during precipitation, or start application in the event precipitation is threatening, unless proper precautions have been taken.

1.7 ENVIRONMENTAL REQUIREMENTS

- A. Do not apply insulation during inclement weather. Temperatures must be a minimum of 40° Fahrenheit and rising. Do not apply insulation material to damp or frozen deck or substrate.
- B. Do not apply insulation when the wind is determined to be detrimental to safe installation practices.

PART 2 - PRODUCTS

2.1 MATERIALS

- A. General: Preformed roof insulation boards manufactured or approved by roofing manufacturer, selected from manufacturer's standard sizes suitable for application, of thicknesses indicated.
- B. Polyisocyanurate Insulation Board: ASTM C-1289 with inorganic glass fiber mat facers.
 - 1. Maximum Board Size:
 - a. 48-inches x 96-inches, where mechanically fastened to metal deck.
 - b. 48-inches x 48-inches where adhesively applied at thicknesses of 8 inches or more.
 - 2. Board thickness: (2) layers – maximum 2-inch thick per layer.
- C. Crickets: Provide factory tapered polyisocyanurate insulation boards with the same characteristics as Article 2.1.B above.
 - 1. Widths of crickets and saddles shall not be less than 1/3 their lengths, unless otherwise shown on Drawings.
- D. Roof Cover Board: "DensDeck Prime," gypsum roof board, as produced by Georgia-Pacific, or "Securock," as produced by U.S. Gypsum.
 - 1. Over Field of Roof Insulation: 1/2-inch thickness.
 - 2. Over Cants and Roof Curbs & Vertical Wood Surfaces: 1/4-inch thickness.
 - 3. Board Size:
 - a. 48 inches x 48 inches where adhesively applied.
 - 4. Miter edges of 1/4-inch roof board strips at tops and bottoms of cants.

2.2 INSULATION ACCESSORIES

- A. General: Furnish roof insulation accessories recommended by insulation manufacturer for intended use and compatibility with membrane roofing.
- B. Fasteners for Metal Decks: Coated steel insulation screws, using metal disks, and of sufficient length for proper penetration of roof deck in all instances.
 - 1. Fastener length shall not exceed 8" – additional insulation shall be set in adhesive
- C. Insulation Adhesive: For use in adhering rigid insulation board, fiber cant strips and gypsum cover board in field of roof and at curbs and other vertical flashing surfaces:
 - 1. OlyBond 500
 - 2. Or as recommended by membrane manufacturer.
- D. Cant Strips:
 - 1. Fire-retardant wood fiber or perlite, meeting ASTM C-728.
 - 2. Size: 4 inches x 4 inches.

2.3 MANUFACTURERS

- A. The manufacturer of the insulation shall be approved in writing by the manufacturer of the roof membrane system. Submit manufacturer's letter.
- B. Include insulation as part of 20-year NDL warranty required for overall roofing system.

PART 3 - EXECUTION

3.1 INSPECTION AND PREPARATION

- A. Verify that surfaces and site conditions are ready to receive work and that deck is supported and secured.
- B. Verify the deck is clean and smooth, free of depressions, waves, or projections.
- C. Verify that roof openings, curbs, pipes, sleeves, ducts, and vents through the roof are solidly set and wood nailing strips are in place.
- D. Fill gaps in deck to prevent roofing products from passing to building interior, or below the deck.
- E. Beginning of installation means installer accepts existing surfaces.

3.2 INSULATION INSTALLATION

- A. Mechanically Fastened Installation at Metal Decks: Over new metal decks lay insulation with long side parallel to the flutes and mechanically fasten with the specified screws and plates.
 - 1. Mechanical fastening shall be in accordance with ASCE 7-10 requirements.
 - 2. Board edges shall not fall over open flutes.
 - 3. Stagger all joints.
 - 4. Screws shall be of sufficient length to penetrate the existing deck by approximately 1 inch.
 - 5. Screws shall not exceed 8" in length
- B. All insulation shall be laid in full sheets wherever possible, and carefully fitted and pushed against adjoining sheets or nailers, to form a tight joint. Fill open joints with tightly-fit pieces of matching roof insulation. Do not install more insulation than can be covered during each day's operation.
- C. Cricket Installation:
 - 1. Apply solidly in full embedment of low-rise foam adhesive.
 - 2. Slope materials a minimum of twice the slope of the aggregate roof slope over which crickets and saddles are installed.
 - 3. Extend cricket widths not less than 1/3 their lengths, unless otherwise detailed.

3.3 COVER BOARD INSTALLATION

- A. Install 1/2-inch thick roof cover board over field of insulation board in adhesive per manufacturer's requirements to achieve wind uplift pressures specified in Part 1 "Performance Requirements" of this Section.
- B. Miter cover board edges where ridges are formed at tops and bottoms of crickets, to prevent open or irregular joints.
- C. Solidly adhere cant strips in full embedment of low-rise foam adhesive at vertical terminations.
- D. Cover combustible cants and roof curb blocking with 1/4-inch roof cover board.
 - 1. Mechanically fasten to wood blocking with galvanized ring shank cap nails.
 - 2. Set in full embedment of low-rise foam adhesive at non-nailable substrates.
- E. Leave surfaces clean in preparation for roof membrane installation.

END OF SECTION 07 2200

SECTION 07 5216 - MODIFIED BITUMEN ROOF SYSTEM

PART 1 - GENERAL

1.1 RELATED DOCUMENTS

- A. Drawings and general provisions of the Contract, including General and Supplementary Conditions and Division 01 Specification Sections, apply to this Section.

1.2 SUMMARY

- A. Section Includes:
 - 1. Qualifications, Standards and Materials for new roof assembly.
 - 2. SBS modified bituminous membrane roofing.
 - 3. Traffic pads.
- B. Related Sections
 - 1. Section 01 7830 - Roofing Warranty
 - 2. Section 06 1050 - Roof Carpentry
 - 3. Section 07 0151 - Roof Removal Procedures
 - 4. Section 07 6200 - Flashing and Sheet Metal

1.3 DEFINITIONS

- A. Roofing Terminology: See ASTM D 1079 and glossary of NRCA's "The NRCA Roofing and Waterproofing Manual" for definition of terms related to roofing work in this Section.

1.4 REFERENCES

- A. American Society for Testing and Materials (ASTM):
 - 1. C 1289 Faced Rigid Cellular Polyisocyanurate Thermal Insulation Board.
 - 2. D 41 Asphalt Primer Used in Roofing.
 - 3. D 4586 Asphalt Roof Cement - Asbestos Free.
 - 4. D 4601 Asphalt-Coated Glass Fiber Base Sheet Used in Roofing.
 - 5. D 6163-97 Standard Specification for SBS Modified Bituminous Sheet Materials using Glass Fiber Reinforcement.
- B. ASCE 7-10 Minimum Design Loads for Buildings and Other Structures
- C. FM, 1-SH Roof Assembly Classification for Severe Hail Exposure.
- D. FM Approval Standards FM 4450 and FM 4470.
- E. NRCA "Handbook of Accepted Roofing Knowledge."
- F. NRCA "Roofing and Waterproofing Manual," 1999 edition.
- G. UL Class A Fire Rating.
- H. National Roofing Contractors Association (NRCA):
 - 1. Manual of Roof Maintenance and Roof Repair.
 - 2. Roofing and Waterproofing Manual.
- I. Underwriters' Laboratories (UL): Fire Hazard Clarifications.

1.5 PERFORMANCE REQUIREMENTS

- A. General Performance: Provide installed membrane roofing and base flashings that withstand specified uplift pressures, thermally induced movement, and exposure to weather without failure due to defective manufacture, fabrication, installation, or other defects in construction. Membrane roofing and base flashings shall remain watertight.
- B. Material Compatibility: Provide roofing materials that are compatible with one another under conditions of service and application required, as demonstrated by membrane roofing manufacturer based on testing and field experience.
- C. Roof System Design: Provide a roofing system that meets or exceeds the wind uplift pressures shown on the drawings.
- D. Approval Standards: Meet testing standards of FM 4450 and FM 4470.
- E. Roof membrane system to be Energy Star compliant and meet all other City of Austin Energy Code requirements.
- F. All sealants, adhesives, coatings and sealant primers shall comply with SCAQMD rules 1113 and 1168 as consistent with performance and warranty requirements.

1.6 SUBMITTALS

- A. Product List: Submit list of proposed Products and manufacturers, including all items specified in Part 2 – Products or otherwise required by the Work.
- B. Product Data: For each type of product indicated.
- C. Manufacturer's Certification: Provide current letter(s) on membrane manufacturer's letterhead, signed by an authorized employee or corporate officer attesting to following:
 - 1. Products: Certify that roofing system complies with requirements specified in "Performance Requirements" Article.
 - 2. Manufacturer Certificates: Signed by roofing manufacturer certifying that roofing system complies with requirements specified in "Performance Requirements" Article. Include evidence of compliance with Performance Requirements Article, including that:
 - a. Roofing system components are physically and chemically compatible for installation as designed, and;
 - b. All proposed materials, including those by other manufacturer, are acceptable to membrane manufacturer for use in system, and;
 - c. Proposed system meets all criteria for issuance of required manufacturer's warranty.
 - d. Specifically identify and define any deviations.
- D. Submit product data indicating the solar reflectance and solar reflectance index (SRI) of roofing.
- E. Submit product data and MSDS for all sealants, adhesives, coatings and sealant primers, indicating the VOC content in g/l of each product.

1.7 QUALITY ASSURANCE

- A. Manufacturer Qualifications: As listed in Article 2.1.
- B. Installer Qualifications: A qualified firm that has been continuously approved, authorized, or licensed by roofing system manufacturer to install manufacturer's product and specified roof system for minimum of five years prior to Bid Date, and that is eligible to receive manufacturer's NDL warranty; with minimum of five three years documented experience, including:

1. Certified by roofing materials manufacturer as an approved NDL applicator for minimum of five years prior to Bid Date, and qualified to provide specified warranty on selected systems and flashings.
 2. Successful completion of minimum five (5) projects of comparable size and specified systems during that time.
 3. All torching operations must be performed by CERTA (Certified Roofing Torch Applicator) trained applicators with up to date certifications.
- C. Workers: All roofers and laborers to be direct employees of Primary Contractor.
1. Project Manager and Superintendent: Minimum five years roofing experience and employed by Contractor for a minimum one year prior to Bid Date.
 2. Non-working Supervisor: Able to communicate effectively with School staff and Applicator's workers and employed by Contractor for a minimum one year prior to Bid Date.
 3. Tradesmen: Minimum 50-percent of installation crew to have been employed by Contractor for a minimum six months prior to Bid Date.
- D. Testing Agency Qualifications: An independent testing agency with the experience and capability to conduct the testing indicated, as documented according to ASTM E 548.
- E. Source Limitations: Obtain components for roofing system from or approved by roofing system manufacturer.
- F. Perform Work in accordance with NRCA Manual of Roof Maintenance and Roof Repair, NRCA Roofing and Waterproofing Manual, and manufacturer's instructions.
- G. Install all roofing materials using personnel directly employed by Applicator (Roofing Contractor) with NDL certification from roofing material manufacturer - no Sub-Contracting permitted.
- H. Assign a qualified, full time, non-working supervisor to be on Project site at all times during installation of Work.
- I. Designate a responsible Project Manager or Superintendent to inspect all installed Work, particularly tie-ins and temporary flashings, at end of each working day and as otherwise required to ensure water-tightness.
1. Verify Inspection by signature on approved Daily Inspection Form signifying installation is in accordance with specified requirements.
- J. Fire-Resistance Ratings: Where indicated, provide fire-resistance-rated roof assemblies identical to those of assemblies tested for fire resistance per ASTM E 119 by a qualified testing agency. Identify products with appropriate markings of applicable testing agency.
- K. Pre-Roofing Conference: Before starting roof demolition, conduct conference.
1. Meet with Owner, Architect, roofing Installer, roofing system manufacturer's representative, and installers whose work interfaces with or affects roofing, including installers of roof accessories and roof-mounted equipment.
 2. Review methods and procedures related to roofing installation, including manufacturer's written instructions.
 3. Review and finalize construction schedule and verify availability of materials, Installer's personnel, equipment, and facilities needed to make progress and avoid delays.
 4. Review structural loading limitations of roof deck during and after roofing.
 5. Review base flashings, special roofing details, roof drainage, roof penetrations, equipment curbs, and condition of other construction that will affect roofing system.
 6. Review governing regulations and requirements for insurance and certificates if applicable.
 7. Review temporary protection requirements for roofing system during and after installation.
 8. Review roof observation and repair procedures after roofing installation.
- L. Do not allow materials which have not been approved through the submittal process to be brought

onto the project site. Any materials brought onto the site which have not been approved through the submittal process will be rejected and shall be removed immediately. Remove - without appeal or exception - any materials incorporated into the Work, which have not been approved through the submittal process.

- M. The manufacturer's representative shall make a minimum of two (2) site visits to the project per month at critical stages of the roof installation, and forward to the Architect written reports of the observations and instructions given to the Contractor during these visits. Coordinate the visits to take place at the time of the Architect's visits, with one occurring at the monthly pay application meeting. Include at the minimum the following information in manufacturer's representative's reports:
1. Prepare reports typewritten on the manufacturer's letterhead stationery, and submit to the Architect within seven (7) days of the site visit.
 2. Document Work in progress and list all deficiencies, corrective actions and recommendations.
 3. Failure of the manufacturer's representative to provide the required reports is cause for rejection of the Contractor's pay application.
- N. Project Record Documents: Accurately record exact location of all roof membrane penetrations and all authorized changes to Contract Documents.

1.8 REGULATORY REQUIREMENTS

- A. Conform to applicable local codes for roof assembly fire hazard requirements and application procedures.
- B. Provide certification of inspection confirming approval of design and installation by authority having jurisdiction.
- C. Fire-Test-Response Characteristics: Provide roofing materials with the fire-test-response characteristics indicated as determined by testing identical products per test method below by UL, FMG, or another testing and inspecting agency acceptable to authorities having jurisdiction. Materials shall be identified with appropriate markings of applicable testing and inspecting agency.
1. Exterior Fire-Test Exposure: Class A; ASTM E 108, for application and roof slopes indicated.
 2. Fire-Resistance Ratings: ASTM E 119, for fire-resistance-rated roof assemblies of which roofing system is a part.

1.9 DELIVERY, STORAGE, AND HANDLING

- A. Deliver roofing materials to Project site in original containers with seals unbroken and labeled with manufacturer's name, product brand name and type, date of manufacture, approval or listing agency markings, and directions for storing and mixing with other components.
1. Inspect for damage.
 2. Store products in weather protected environment, clear of ground and moisture.
 3. Stand and store roll materials on end.
- B. Store liquid materials in their original undamaged containers in a clean, dry, protected location and within the temperature range required by roofing system manufacturer. Protect stored liquid material from direct sunlight.
1. Discard and legally dispose of liquid material that cannot be applied within its stated shelf life
- C. Handle and store roofing materials and place equipment in a manner to avoid permanent deflection of deck.
1. Do not store more materials on roof overnight unless approved by the Architect.
 2. Maximum Allowable Loading on Roof: 20 pounds per square foot.

1.10 PROJECT CONDITIONS

- A. Weather Limitations: Proceed with installation only when existing and forecasted weather conditions permit roofing system to be installed according to manufacturer's written instructions and warranty requirements.
 - 1. Do not apply roofing membrane during inclement weather.
 - 2. Do not apply roofing membrane to damp or frozen deck surface.
 - 3. Observe wind chill and other cold weather conditions for proper bituminous application.

1.11 SEQUENCING AND SCHEDULING

- A. Coordinate work under provisions of Division 01 Section "Administration Requirements."
- B. Coordinate with demolition work and with work of other trades to ensure sufficient materials and manpower are available to complete and make watertight all roofing Work each day.
- C. Limit tear off of existing roof system to amount that can be completely covered with new roof system and made watertight by end of day.
- D. Coordinate installation of associated metal flashings, and roof-related items as work of this Section proceeds. Strip-in all flanged metal components to roof membrane on same day they are installed.
- E. Schedule work to avoid storage on and traffic over finished work.
- F. Upon completion of Work each day that torching operations occur, provide a full 1-hour fire watch by a competent person, trained to detect possible smoke or fire resulting from roofing operations. Should the competent person detect smoke or fire he shall immediately place a telephone call to the Fire Department through the 911 exchange.
- G. Mount and maintain a minimum of two (2) fully charged and workable 3A60BC class fire extinguishers at the roof level at all times Work is underway. Position fire extinguishers within 25 feet of torching operations. Train all workers in proper fire extinguisher use.

1.12 WARRANTIES

- A. Provide a two-year written warranty covering defects in the roofing materials and labor, on the form in Section 01 7830.
- B. The Contractor shall be responsible for repairing any defect attributable to Contractor's method or manner of installation of the roof membrane during the two-year period at Contractor's sole cost and expense.
 - 1. During the eleventh month following the Contractor's date of substantial completion, the Contractor shall have thirty (30) days to coordinate and perform a roof inspection with the roof material manufacturer's representative and the Owner's representative.
 - 2. Contractor shall coordinate and perform a roof inspection with the roof material manufacturer's representative and the Owner's representative during the ninety (90) day period preceding the expiration date of the two-year warranty.
 - 3. Failure to perform inspections specified above and repair defects (if any) will be cause to consider the Contractor in default. The Owner will then submit written notice of default to the Contractor's bonding company.
- C. Provide the roofing materials manufacturer's 20-year no-dollar-limit type warranty covering repair of defects in the insulation, roofing and composition flashings, and repair of interply blistering.
- D. Commence all warranties on the Date of Substantial Completion for the overall project.
- E. Provide three (3) Roof Warranty Signs at the completion of the project. Signs shall be placed on

roof at locations determined by the Owner.

1. Warranty Signs: 24"x24"x.080 aluminum with a baked enamel background and black lettering, in a non-penetrating manner, to read as follows:

WARNING:

THIS ROOF IS UNDER WARRANTY UNTIL
(Date)
(MANUFACTURER)
(Manufacturer's Phone No.)

**DO NOT MAKE ALTERATIONS OR REPAIRS
TO THIS ROOF WITHOUT APPROVAL FROM AISD**

CONTACT
AISD DEPARTMENT OF CONSTRUCTION MANAGEMENT
512-414-1715
FOR APPROVAL AND/OR TO REPORT DAMAGE REQUIRING REPAIRS

PART 2 - PRODUCTS

2.1 SBS-MODIFIED BITUMEN MANUFACTURERS

- A. Siplast
- B. Derbigum
- C. Johns Manville
- D. U.S. Ply

2.2 SHEET MATERIALS

- A. Modified Bitumen Base Ply: Fiberglass or polyester mat, coated with SBS or APP modified asphalt.
 1. Siplast: Paradiene 20 TG
 2. Derbigum: Derbibase Ultra
 3. Johns Manville: DynaWeld Base
 4. U.S. Ply: DuraFlex 90 TG SBS Base
- B. Modified Bitumen Cap Ply: Fiberglass or polyester reinforced SBS or APP modified bitumen, with white reflective surfacing.
 1. Siplast: Paradiene 30 FR TG BW
 2. Derbigum: Derbicolor P-FR-CR
 3. Johns Manville: DynaKap FR T1 HW CR G
 4. U.S. Ply: DuraFlex G4FRTG SBS Ultra White

2.3 FLEXIBLE FLASHINGS

- A. Backer Ply: Fiberglass or polyester mat, coated with SBS or APP modified bitumen, having a smooth surface.
 1. Siplast: Paradiene 20 TG
 2. Derbigum: Derbibase Ultra
 3. Johns Manville: DynaWeld Base
 4. U.S. Ply: DuraFlex 90 TG SBS Base

- B. Base Flashing Finish Ply: Fiberglass or polyester mat coated with modified bitumen and metal foil surface. The flashing system is to be approved by the membrane manufacturer for use with its respective system.
1. Siplast: Veral Aluminum
 2. Derbigum: Derbicolor P-FR-CR
 3. Johns Manville: DynaClad
 4. U.S. Ply: DuraFlex Alum SS

2.4 AUXILIARY ROOFING MEMBRANE MATERIALS

- A. Asphalt Primer: ASTM D41 as approved by membrane manufacturer. Asphalt primer shall comply with current VOC limits and SCAQMD rule 1168 as consistent with performance and warranty requirements.
- B. Asphalt Roof Cement: ASTM D4586, Type I, non-asbestos, as approved by membrane manufacturer. Asphalt Roof Cement shall comply with current VOC limits and SCAQMD rule 1168 as consistent with performance and warranty requirements.
- C. Flashing Cement: Compatible with SBS modified bitumen membrane. Flashing Cement shall comply with current VOC limits and SCAQMD rule 1168 as consistent with performance and warranty requirements.
- D. Fasteners: Factory-coated steel fasteners and metal or plastic plates complying with corrosion-resistance provisions in FMG Approvals 4470; designed for fastening roofing membrane components to substrate; tested by manufacturer for required pullout strength, and acceptable to roofing system manufacturer.
1. Mechanical Fasteners for Flexible Flashing:
 - a. Masonry: 0.25-inch x 1.5-inch zinc-jacketed steel masonry drive pin; Zamac "Hammer Screw," or an approved equal.
 - b. Wood Blocking: Stainless steel (for fastening into ACQ treated lumber) or high carbon, zinc coated steel (for fastening into non- ACQ treated lumber); annular threaded 1-inch shank nails; with minimum 1-inch x 30 gage metal disk; Roofing Nail, manufactured by Simplex Nails, Inc.
 2. Roofing Nails:
 - a. Stainless steel for fastening into ACQ treated lumber.
 - b. Hot-dipped galvanized or non-ferrous type for fastening into non-treated lumber.
 - c. Provide with annular rings, size as required to suit application; minimum 11-gage with 3/8-inch diameter head.
- E. Roofing Granules: Ceramic-coated roofing granules, No. 11 screen size with 100 percent passing No. 8 sieve and 98 percent of mass retained on No. 40 sieve, color to match roofing membrane.
- F. Termination Bars: 12-ga. or 1/8-inch x 1-inch hot-dipped galvanized steel bar stock.
- G. Roof Protection Pads: Roofing manufacturer's standard roof (walkway) protection pads, consisting of modified bitumen layers and including an integral white granule top surface. Install pads in sizes and patterns shown on Drawings.
- H. Expansion Joint Filler:
 1. Flexible Vapor Retarder: Minimum 60 mil thick vinyl sheet, or approved equal.
 2. Compressible Insulation: Fiberglass batt insulation, or approved equal.

PART 3 - EXECUTION

3.1 EXAMINATION

- A. Verify that surfaces and site conditions are ready to receive work and that deck is supported and secured.
- B. Verify the deck is clean and smooth, free of depressions, waves, or projections, properly sloped to drains or eaves.
- C. Verify that deck surfaces are dry and free of snow or ice. Verify flutes of metal deck are clean and dry. Confirm deck dryness by moisture meter; maximum allowable: 12-percent.
- D. Verify that roof openings, curbs, pipes, sleeves, ducts, and vents through the roof are solidly set and wood nailing strips are in place.
- E. Beginning of installation means installer accepts existing surfaces.

3.2 PREPARATION

- A. Clean substrate of dust, debris, moisture, and other substances detrimental to roofing installation according to roofing system manufacturer's written instructions. Remove sharp projections.
- B. Prevent materials from entering and clogging roof drains and conductors and from spilling or migrating onto surfaces of other construction. Remove temporary closures or roof-drain plugs prior to leaving the job site each day.

3.3 ROOFING MEMBRANE INSTALLATION, GENERAL

- A. Install roofing membrane system according to roofing system manufacturer's written instructions and applicable recommendations in ARMA/NRCA's "Quality Control Guidelines for the Application of Polymer Modified Bitumen Roofing" and as follows:
 - 1. Deck Type: Insulated.
 - 2. Adhering Method: Torch.
 - 3. Number of Modified Asphalt Sheets: Two.
 - 4. Surfacing Type: Reflective.
- B. Cooperate with testing agencies engaged or required to perform services for installing roofing system.
- C. Coordinate installing roofing system so components of the roofing membrane system not permanently exposed are not subjected to precipitation or left uncovered at the end of the workday or when rain is forecast.
 - 1. Provide tie-offs at end of each day's work to cover exposed roofing membrane sheets with a course of coated felt set in roofing cement or hot roofing asphalt with joints and edges sealed.
 - 2. Complete terminations and base flashings and provide temporary seals to prevent water from entering completed sections of roofing system.
 - 3. Remove and discard temporary seals before beginning work on adjoining roofing.

3.4 MODIFIED BITUMINOUS MEMBRANE INSTALLATION

- D. Install modified bituminous roofing membrane sheet and cap sheet per roofing manufacturer's written instructions, starting at low point of roofing system. Extend roofing membrane sheets over and terminate beyond cants.
 - 1. Unroll roofing membrane sheets and allow them to relax for approximately 30 minutes or the minimum time period required by manufacturer.
- B. Starting at low point of roof (eaves), lay modified bitumen base ply perpendicular to roof slope and torch in place over specified cover board per manufacturer's written instructions. Fully adhere the

base ply to the substrate by continuous torching of the plies. Lightly trowel the edges of each ply.

- C. Torch and seal one additional ply of base ply around roof penetrations prior to installation of cap ply.
- D. Apply cap ply parallel to base ply in accordance with manufacturer's instructions.
 - 1. Fully torch cap ply to the previously installed base ply, providing 3-inch side and end laps or per manufacturer's requirements.
 - 2. Stagger lap joints between base ply and cap ply. Stagger lap joints between adjacent cap plies by a minimum of 12 inches.
 - 3. Where cap ply is applied over a granule surface of previously installed ply, apply asphalt primer to surface of granular ply and allow ply to dry prior to torching the next ply.
 - 4. Limit modified bitumen bleed at ply laps to no more than 0.5 inch. Lightly trowel edges of ply while bitumen remains hot.
- E. Laps: Accurately align roofing membrane sheets, without stretching, and maintain uniform side and end laps. Stagger end laps. Completely bond and seal laps, leaving no voids.
 - 1. Repair tears and voids in laps and lapped seams not completely sealed.
 - 2. Apply roofing granules to cover exuded bead at laps while bead is hot.
- F. Install roofing membrane sheets so side and end laps shed water.

3.5 FLASHING AND STRIPPING INSTALLATION

- G. Install base flashing over cant strips and other sloped and vertical surfaces, at roof edges, and at penetrations through roof; secure to substrates according to roofing system manufacturer's written instructions, and as follows:
 - 1. Prime substrates with asphalt primer if required by roofing system manufacturer.
 - 2. Backer Sheet Application: Adhere backer sheet to substrate by torch application.
 - 3. Flashing Sheet Application: Torch apply flashing sheet to backer sheet.
 - 4. Maximum flashing base and top ply width: Width of roll.
 - 5. Extend base flashing up vertical surfaces a minimum of 8-inches above roofing membrane and 4-inches onto field of roofing membrane.
 - 6. Mechanically fasten top of base flashing securely at terminations and perimeter of roofing at 8-inches on center and as shown in the drawings.
- H. Install roofing membrane cap-sheet stripping where metal flanges and edgings are set on membrane roofing according to roofing system manufacturer's written instructions. Install strip in ply on the same day as the sheet metal penetration flashing or roof perimeter metal edge is installed.
- I. Apply metallic coating over all bitumen overruns on flashing surface.
- J. Coordinate installation of roof drains, sumps, and related flashings.

3.6 WALKWAY INSTALLATION

- A. Walkway Pads: Install walkway pads using units of size indicated or, if not indicated, of manufacturer's standard size according to walkway pad manufacturer's written instructions.
 - 1. Set walkway pads in cold-applied adhesive or by torch application.
 - 2. Locations: Where indicated and at each rooftop unit (RTU) with operable components, at base and top of each roof ladder, and at each roof hatch.
 - 3. Install a minimum of two pads adjacent to each RTU access panel; roof ladder, and on three sides of each roof hatch; or match width of access panel, ladder, or hatch plus 12-inches each side. Set joints 6 inches apart.

3.7 FIELD QUALITY CONTROL

- A. Test Cuts: Test specimens may be removed to evaluate problems observed during quality-assurance inspections of roofing membrane. Assist in securing roof cuts and patch roof as required to finished condition at no added cost to the Owner.
- B. Promptly correct all identified defects and irregularities. Repair all membrane defects called to the attention of the Project Superintendent prior to the end of each day, unless directed otherwise.
- C. Demolition operations may not be performed during application of the new roofing system.
- D. Final Roof Inspection: Arrange for roofing system manufacturer's technical personnel to inspect roofing installation on completion.
 - 1. Notify Architect and Owner 48 hours in advance of date and time of inspection.

3.8 MANUFACTURER'S FIELD SERVICES

- A. Provide manufacturer's field services under provisions of Division 01 Section "Quality Requirements."
- B. Request site attendance of roofing materials manufacturers during installation of the work.
- C. Post Construction Inspection: Contractor and manufacturer's representative to inspect roofing installation 23 months after Substantial Completion and prior to expiration of Contractor's Warranty.

3.9 PROTECTING AND CLEANING

- A. Protect roofing system from damage and wear during remainder of construction period. When remaining construction will not affect or endanger roofing, inspect roofing for deterioration and damage, describing its nature and extent in a written report, with copies to Architect and Owner.
- B. Correct deficiencies in or remove roofing system that does not comply with requirements, repair substrates, and repair or reinstall roofing system to a condition free of damage and deterioration at time of Substantial Completion and according to warranty requirements.
- C. Clean overspray and spillage from adjacent construction using cleaning agents and procedures recommended by manufacturer of affected construction.
- D. Remove bituminous markings from all finished surfaces.
- E. In areas where finished surfaces are soiled by bitumen or any other source of soiling caused by Work of this Section, consult manufacturer of surfaces for cleaning advice, and conform to their documented instructions. Replace any materials or finishes which cannot be cleaned to the Owner's satisfaction.

END OF SECTION 07 5216

SECTION 07 5600 - FLUID APPLIED FLASHING

PART 1 - GENERAL

1.1 RELATED DOCUMENTS

- A. Drawings and general provisions of the Contract, including General and Supplementary Conditions and other Division 01 through Division 26 Specification Sections, apply to this Section.

1.2 SUMMARY

- A. Section Includes:
 - 1. Fluid applied flashing.
 - 2. Preparation of Substrate to Receive Flashing Materials
- B. Related Sections:
 - 1. Section 07 5216 - Modified Bitumen Roof System
 - 2. Section 07 6200 - Flashing and Sheet Metal

1.3 SUBMITTALS

- A. Provide submittals in accordance with requirements of Section 01300 – Submittal Procedures.
- B. Letter from the manufacturer confirming that the bidder is an acceptable Contractor authorized to install the proposed flashing system.
- C. Provide product data for each material to be employed in the Work.
- D. Mark each proposed item in product data by circling or highlighting, and affixing the corresponding Article and Paragraph numbers from this Specification. Product data not so marked will be returned to the Contractor without review, for re-submittal complying with the above requirements.

1.4 QUALITY ASSURANCE

- A. Product Quality Assurance Program: Flashing materials shall be manufactured under a quality management system that is monitored regularly by a third-party auditor under the ISO 9001:2000 audit process. A certificate of analysis for reporting/confirming the tested values of the actual material being supplied for the project will be required prior to project close-out.
- B. Agency Approvals: The proposed roof flashing system shall conform to the following requirements. No other testing agency approvals will be accepted.
 - 1. Underwriters Laboratories Class A acceptance of the proposed roofing system based upon testing performed in accordance with ASTM E 108 protocol.
- C. Project Acceptance: Submit a completed manufacturer's application for flashing guarantee form.
 - 1. The form shall contain all the technical information applicable to the project and materials proposed for installation.
 - 2. The form shall also contain accurate and complete information requested including proper names, addresses, zip codes and telephone numbers.
 - 3. The project must receive approval by the flashing manufacturer, through this process, prior to shipment of materials to the project site.
- D. Scope of Work: Includes but is not limited to the following:
 - 1. Attend necessary job meetings.

2. Furnish competent and full-time supervision, experienced roof mechanics, all materials, tools and equipment necessary to complete, in an acceptable manner, the flashing installation in accordance with this Specification.
 2. Comply with the latest written application instructions of the manufacturer of the primary roofing/flashing products.
- E. Local Regulations: Conform to regulations of public agencies, including any specific requirements of the city and/or state of jurisdiction.
- F. Manufacturer Requirements: The flashing system manufacturer shall provide direct trained company personnel to attend necessary job meetings, perform periodic inspections as necessary and conduct a final inspection upon successful completion of the project.
- 1.5 PRODUCT HANDLING, STORAGE AND DELIVERY
- A. Deliver packaged materials to site in manufacturer's original, unopened labeled containers in quantities required to allow continuity of application.
- B. All solvents, cleaners and coatings shall be stored in a fenced or other fully secured area. No material is to be stored in any existing building under any condition.
1. Lids shall be fully secured on the cans and materials shall not be allowed to mix with one another.
 2. Store closed containers in a cool, dry area away from heat, direct sunlight, oxidizing agents, strong acids, and strong alkalis.
 3. Do not store resins at temperatures below 32°F (0°C) or above 85°F (29°C). Keep away from open fire, flame or any ignition source.
 4. Store in a well-ventilated area. Resin products may auto-polymerize at temperatures greater than 140°F.
- C. Handling:
1. Handle all materials in such a manner as to preclude damage and contamination with moisture or foreign matter.
 2. Keep away from open fire, flame, or any ignition source. Vapors may form explosive mixtures with air.
 3. Avoid skin and eye contact with this material.
 4. Avoid breathing fumes when above the Threshold Limit Value (TLV).
 5. Do not eat, drink or smoke in the application area.
- D. Damaged Material: Any materials that are found to be damaged or stored in any manner other than stated above shall be automatically rejected, removed and replaced at the Contractor's expense.

1.6 JOB CONDITIONS

- A. Requirements Prior to Job Start:
1. Notification: Give a minimum of five (5) days notice to the Owner and manufacturer prior to commencing any Work and notify both parties on a daily basis of any change in Work schedule.
 2. Permits: Obtain all permits required by local agencies and pay all fees which may be required for the performance of the Work.
 3. Safety: Familiarize every member of the application crew with all fire and safety regulations recommended by OSHA, NIOSH, NRCA and other industry or local governmental groups.
 - a. Workers shall wear a long sleeve shirt with long pants and Work boots.
 - b. Workers shall use only butyl rubber or nitrile gloves when mixing or applying fluid

flashing products.

- c. Safety glasses with side shields are required for eye protection.
- d. Use local exhaust ventilation to maintain Worker exposure below the published Threshold Limit Value (TLV).
- e. If the airborne concentration poses a health hazard, becomes irritating or exceeds recommended limits, use a NIOSH approved respirator in accordance with OSHA Respirator Protection requirements published under 29 CFR 1910.134. The specific type of respirator will depend on the airborne concentration.
- f. A filtering face piece or dust mask is not acceptable for use with this product if TLV filtering levels have been exceeded.

B. Environmental Requirements:

1. Precipitation: Do not apply fluid flashing materials during precipitation or in the event there is a probability of precipitation during application. Take adequate precautions to ensure that materials and building interiors are protected from possible moisture damage or contamination.
2. Temperature Restrictions – Primer Resins: Do not apply primer resin if there is a threat of inclement weather. Apply the primer resin while air temperature is between 32°F (0°C) and 104°F (40°C), and while the substrate temperature is between 32°F (0°C) and 122°F (50°C). Do not apply resin materials when ambient or substrate temperatures exceed that indicated above.
3. Temperature Restrictions – Summer Grade Roofing Resins: Do not apply roofing resins if there is a threat of inclement weather. Apply membrane resin while air temperature is between 59°F (15°C) and 104°F (40°C), providing the substrate temperature is between 50°F (10°C) and 122°F (50°C). Do not apply materials when ambient or substrate temperatures exceed that indicated above.

C. Protection Requirements:

1. Membrane Protection: Provide protection against staining and mechanical damage for newly applied roofing and adjacent surfaces.

1.7 REFERENCE STANDARDS

References in these specifications to standards, test methods and codes, are implied to mean the latest edition of each such standard adopted. The following is an abbreviated list of associations, institutions and societies which may be used as references throughout these specifications:

- | | | |
|----|------|---|
| A. | ASTM | American Society for Testing and Materials, Philadelphia, PA |
| B. | FM | Factory Mutual Engineering and Research, Norwood, MA |
| C. | NRCA | National Roofing Contractors Association, Rosemont, IL |
| D. | OSHA | Occupational Safety and Health Administration, Washington, DC |
| E. | UL | Underwriters Laboratories, Northbrook, IL |
| F. | ACI | American Concrete Institute, Hills, MI |

1.8 WARRANTY

- A. Provide a two-year written warranty against defects in materials and Workmanship, beginning on the date of Substantial Completion of the overall Project, and executed on the form found in Section 01 7830.

- B. Provide a manufacturer's 20-year no-dollar-limit type warranty covering repair of defects in fluid-applied flashing.

PART 2 - PRODUCTS

2.1 MEMBRANE / FLASHING SYSTEM

- A. Catalyst: A reactive agent used to induce curing of polymethylmethacrylate (PMMA) resins.
 - 1. Siplast: "Pro Catalyst"
 - 2. U.S. Ply: Liqua-Ply Catalyst or as approved by manufacturer.
 - 3. Johns Manville: Seamfree™ PMMA Catalyst
 - 4. Prior approved equal.
- B. Resin for Membrane and Flashing Applications: A flexible, PMMA-based resin for use in combination with a polyester fabric to form a monolithic, reinforced roofing or flashing membrane.
 - 1. Siplast: "Parapro Roof Resin"
 - 2. U.S. Ply: Liqua-Ply Flashing or as approved by manufacturer.
 - 3. Johns Manville: Seamfree™ PMMA Flashing Resin
 - 2. Prior approved equal.
- C. Membrane and Flashing Reinforcement: A polyester fabric reinforcement as supplied by the membrane system manufacturer.
 - 1. Siplast: "Pro Fleece"
 - 2. U.S. Ply: USP Polyforcement or as approved by manufacturer.
 - 3. Johns Manville: Seamfree™ PMMA Scrim
 - 2. Prior approved equal.

2.3 AUXILIARY MATERIALS

- A. Elastomeric Sealant: A moisture-curing, non-slump elastomeric sealant designed for roofing applications. The sealant shall be approved by the roof membrane manufacturer for use in conjunction with the roof membrane materials.
- B. Cleaner/Solvent: A clear solvent used to prepare metal and plastic surfaces prior to application of the catalyzed resin flashing membranes and to reactivate transition areas of in-place resin flashing membranes at tie-ins and between staged coats of resin.
- C. Preparation Paste: A multi-component, fast curing, PMMA-based paste used for remediation of depressions in substrate surfaces or other irregularities.
 - 1. Siplast's "Pro Paste Resin," or an approved equal.
- D. Tape: A white, flexible, coated cotton cloth tape designed for treatment of insulation panel joints and deck/wall transitions.
 - 1. Siplast's "Pro Tape," or an approved equal.

PART 3 - EXECUTION

3.1 INSPECTION

- A. The Contractor shall examine the Contract Documents and all conditions which affect the quality of his Work. Deviations or unsatisfactory conditions shall be reported to the Owner's Representative

in writing. No Work shall proceed until conditions are satisfactory to meet requirements of the Contract Documents.

- B. Conduct a pre-roofing conference with the manufacturer's technical representative, applicator and architect prior to ordering materials and starting Work.
 - 1. Discuss the products and application techniques.
 - 2. Written minutes shall be maintained and submitted by the Contractor to the Architect and Owner.
 - 3. The Work and products may be adjusted depending on recommendations of the manufacturer's technical representative.

3.2 SUBSTRATE PREPARATION

- A. Preparation of roof penetrations to receive new membrane flashing: Grind and scrape away all loose dirt, rust, membrane and any other deleterious materials from the surfaces of the piping, conduit or other material scheduled to receive the new coating.
- B. Wipe down affected surfaces with specified cleaner/solvent as recommended by the manufacturer.
- C. Ply Sheet Application: Bond the modified bitumen ply sheet by adhesive application to the prepared substrate, utilizing minimum 3-inch side and end laps. Cut a dog ear angle at the end laps on overlapping selvage edges. Using a clean trowel, apply pressure to top seal T-laps immediately following sheet application. Stagger end laps a minimum of 3-feet. Follow manufacturer's specifications regarding maximum exposure periods prior to application of the liquid-applied finish membrane.

3.3 MIXING OF RESIN PRODUCTS

- A. Preparation/Mixing/Catalyzing Resin Products: Pour the desired quantity of resin into a clean container and using a spiral mixer or mixing paddle, stir the liquid for the time period specified by the resin manufacturer.
- B. Calculate the amount of catalyst powder needed using the manufacturer's guidelines and add the pre-measured catalyst to the primer. Mix again for the time period specified by the resin manufacturer, ensuring that the product is free from swirls and bubbles. It is imperative that air is not entrained into the product during the mixing process. To avoid aeration, do not use a spiral mixer unless the spiral section of the mixer can be fully contained in the liquid during the mixing process.
- C. Mix only enough product to ensure that it can be applied before expiration of resin pot life.

3.4 FLASHING AND FIELD MEMBRANE APPLICATION

- A. Using masking tape, mask the perimeter of the area to receive the flashing system. Apply resin primer to substrates requiring additional preparation and allow primer to set.
- B. Pre-cut reinforcing fabric to ensure a proper fit at transitions and corners prior to membrane application.
- C. Apply an even, generous base coat of flashing resin using a roller at the manufacturer's recommended rate to prepared surfaces requiring flashing coverage.
 - 1. Work the reinforcing fabric into the wet, resin using a brush or roller to fully embed the reinforcing fabric in the resin and remove trapped air.
 - 2. Lap reinforcing fabric layers a minimum of 2-inch (5 cm) and apply an additional coat of

- resin between layers of overlapping fleece.
 - 3. Again, using a roller, apply an even top coat of resin immediately following embedment of the reinforcing fabric, ensuring full saturation of the reinforcing fabric.
 - 4. Ensure that the flashing resin is applied to extend a 0.25-inch (6 mm) beyond the reinforcing fabric. Remove the tape before the resin sets.
 - 5. Make allowances for saturation of roller covers and application equipment.
- D. Should Work be interrupted for more than 12 hours or the surface of the resin becomes dirty or contaminated by the elements, wipe the surface to be lapped with new flashing resin using the specified cleaner/solvent. Allow the surface to dry for a minimum 20 minutes and a maximum 60 minutes before continuing Work.

3.5 FIELD QUALITY CONTROL AND INSPECTIONS

- A. Site Condition: Leave all areas around job site free of debris, roofing materials, equipment and related items after completion of job.
- B. Notification Of Completion: Notify the manufacturer by means of manufacturer's printed Notification of Completion form of job completion in order to schedule a final inspection date.
- C. Post-Installation Meeting: Hold a meeting at the completion of the project, attended by all parties that were present at the pre-job conference. A punch list of items required for completion shall be compiled by the Contractor and the manufacturer's representative. Complete, sign, and mail the punch list form to the manufacturer's headquarters.
- D. Issuance Of The Guarantee: Complete all post installation procedures and meet the manufacturer's final endorsement for issuance of the specified guarantee.

3.6 CLEANING

- A. Clean all roofing surfaces free of overspray materials. Remove all excess materials.
- B. Re-install materials which may have been removed during the Work and ensure all to be in working order.

END OF SECTION 07 5600

SECTION 07 6200 - FLASHING AND SHEET METAL

PART 1 - GENERAL

1.1 RELATED DOCUMENTS

- A. Drawings and general provisions of the Contract, including General and Supplementary Conditions and other Division 01 through Division 26 Specification Sections, apply to this Section.

1.2 SUMMARY

- A. Section Includes:
 - 1. Qualifications, Standards and Materials for prefinished and galvanized sheet metal flashing.
 - 2. Metal wall panels
 - 3. Fasteners.
- B. Related Sections
 - 1. Section 01 7830 - Roofing Installer's Warranty
 - 2. Section 06 1050 - Roof Carpentry
 - 3. Section 07 5216 - Modified Bitumen Roof System

1.3 PERFORMANCE REQUIREMENTS

- A. General: Sheet metal flashing and trim assemblies as indicated shall withstand wind loads, structural movement, thermally induced movement, and exposure to weather without failure due to defective manufacture, fabrication, installation, or other defects in construction. Completed sheet metal flashing and trim shall not rattle, leak, or loosen, and shall remain watertight.
- B. Metal Edge Securement: Except gutter, shall be installed as tested in accordance with the most current version of the ANSI\SPRI ES-1, American National Standard for Edge Systems Used with Low-Slope Roofing Systems.
- C. Thermal Movements: Provide sheet metal roofing that allows for thermal movements resulting from ambient and surface temperatures by preventing buckling, opening of joints, hole elongation, overstressing of components, failure of joint sealants, failure of connections, and other detrimental effects. Base engineering calculation on surface temperatures of materials due to both solar heat gain and nighttime-sky heat loss.
 - 1. Temperature Change (Range): 120 deg F, ambient; 180 deg F, material surfaces.
- D. Water Infiltration: Provide sheet metal roofing that does not allow water infiltration to building interior, with metal flashing and connections of sheet metal roofing lapped to allow moisture to run over and off the material.

1.4 SUBMITTALS

- A. Product Data: For each type of product indicated. Include construction details, material descriptions, dimensions of individual components and profiles, and finishes for each manufactured product and accessory.
- B. Shop Drawings: Show fabrication and installation layouts of sheet metal flashing and trim, including plans, elevations, expansion-joint locations, and keyed details. Distinguish between shop- and field-assembled work. Any deviation from the details shown in the Contract Documents

shall be clearly designated in the shop drawings. Deviations not clearly shown may be cause for rejection of shop drawings without review. Include the following:

1. Identification of material, thickness, weight, and finish for each item and location in Project.
2. Details for forming sheet metal flashing and trim, including profiles, shapes, seams, and dimensions.
3. Details for joining, supporting, and securing sheet metal flashing and trim, including layout of fasteners, cleats, clips, and other attachments. Include pattern of seams.
4. Details of termination points and assemblies, including fixed points.
5. Details of expansion joints and expansion-joint covers, including showing direction of expansion and contraction.
6. Details of edge conditions, including eaves, ridges, valleys, rakes, crickets, and counterflashings as applicable.
7. Details of special conditions.
8. Details of connections to adjoining work.
9. Detail formed flashing and trim at a scale of not less than 3-inches per 12-inches.

- C. In the event that the Contractor intends to comply - without deviation - with the Drawings, shop drawings will not be required as part of this Section.
1. Should any changes from the Contract Document drawings be anticipated - for whatever reason - submit detailed and accurate-to-scale shop drawings, showing the changes and including all components.
 2. Include the date, project name and Drawing Detail number of the detail proposed for change.
 3. Include with initial submittals a letter confirming Contractor's intent to comply with these provisions.
- D. Samples and Color Charts for Initial Selection: For each type of sheet metal flashing, trim, and accessory indicated with factory-applied color finishes involving color selection.

1.5 QUALITY ASSURANCE

- A. Fabricator Qualifications: Shop that employs skilled workers who custom fabricate sheet metal flashing and trim similar to that required for this Project and whose products have a record of successful in-service performance.
- B. Sheet Metal Flashing and Trim Standard: Comply with SMACNA's "Architectural Sheet Metal Manual" unless more stringent requirements are specified or shown on Drawings.
- C. Mockups: Build mockups to verify selections made under sample submittals and to demonstrate aesthetic effects and set quality standards for fabrication and installation.
1. Build mockups including but not limited to, typical roof eave, fascia, gutter, coping, scupper, collector head and downspouts, approximately 10 feet long or per individual item, including supporting construction cleats, seams, attachments and accessories.
 2. Approval of mockups does not constitute approval of deviations from the Contract Documents contained in mockups unless Architect specifically approves such deviations in writing.
 3. Approved mockups may become part of the completed Work if undisturbed at time of Substantial Completion.
- D. Pre-installation Conference:
1. Meet with Owner, Architect, Owner's insurer if applicable, Installer, and installers whose work interfaces with or affects sheet metal flashing and trim including installers of roofing materials, roof accessories, unit skylights, and roof-mounted equipment.
 2. Review methods and procedures related to sheet metal flashing and trim.

3. Examine substrate conditions for compliance with requirements, including flatness and attachment to structural members.
4. Review special roof details, roof drainage, roof penetrations, equipment curbs, and condition of other construction that will affect sheet metal flashing.
5. Document proceedings, including corrective measures and actions required, and furnish copy of record to each participant.

1.6 DELIVERY, STORAGE, AND HANDLING

- A. Do not store sheet metal flashing and trim materials in contact with other materials that might cause staining, denting, or other surface damage. Store sheet metal flashing and trim materials away from uncured concrete and masonry.
- B. Protect strippable protective covering on sheet metal flashing and trim from exposure to sunlight and high humidity, except to the extent necessary for the period of sheet metal flashing and trim installation.

1.7 WARRANTY

- A. Special Warranty on Finishes: Manufacturer's standard form in which manufacturer agrees to repair finish or replace sheet metal flashing and trim that shows evidence of deterioration of factory-applied finishes within specified warranty period.
 1. Exposed Panel Finish: Deterioration includes, but is not limited to, the following:
 - a. Color fading more than 5 Hunter units when tested according to ASTM D 2244.
 - b. Chalking in excess of a No. 8 rating when tested according to ASTM D 4214.
 - c. Cracking, checking, peeling, or failure of paint to adhere to bare metal.
 2. Finish Warranty Period: 20 years from date of Substantial Completion.

PART 2 - PRODUCTS

2.1 SHEET METALS

- A. General: Protect mechanical and other finishes on exposed surfaces from damage by applying a strippable, temporary protective film before shipping.
- B. Sheet Metal Types:
 1. Galvanized Steel: Lock-forming quality G90, meeting ASTM A-653, in 24-gauge thickness, unless otherwise indicated below or on the Drawings.
 2. Stainless Steel: 24-gauge, ASTM A-240, Type 304, fully annealed for fabrication of receivers for rooftop mechanical equipment where shown on the drawings.
 3. Prefinished Metals: 24-gauge, Galvalume® steel, treated, primed and prefinished under precision conditions.
 - a. Exposed Finish: Kynar 500® Fluorocarbon coating. Bottom or unexposed side: manufacturer's standard primer coat. Use for all metals indicated on the Drawings and shown hereafter to be exposed to view, and not designated for other metal types.
 - b. Color: Selected by the Owner from the manufacturer's premium color choices.
 - c. Provide pre-finished metal with manufacturer's standard twenty (20) year finish warranty.
 - d. Deliver pre-finished metal to site with factory-applied protective plastic film, to be removed immediately upon installation.

2.2 UNDERLAYMENT MATERIALS

- A. Self-Adhering, High-Temperature Sheet: Minimum 30 to 40 mils thick, consisting of slip-resisting polyethylene-film top surface laminated to layer of butyl or SBS-modified asphalt adhesive, with release-paper backing; cold applied. Provide primer when recommended by underlayment manufacturer.
1. Thermal Stability: ASTM D 1970; stable after testing at 240 deg F.
 2. Low-Temperature Flexibility: ASTM D 1970; passes after testing at minus 20 deg F.
 3. Products: Subject to compliance with requirements, provide one of the following:
 - a. Carlisle Coatings & Waterproofing Inc.; CCW WIP 300HT.
 - b. Grace Construction Products, a unit of W. R. Grace & Co.; Ultra.

2.3 MISCELLANEOUS MATERIALS

- A. General: Provide materials and types of fasteners, solder, welding rods, protective coatings, separators, sealants, and other miscellaneous items as required for complete sheet metal flashing and trim installation and recommended by manufacturer of primary sheet metal or manufactured item unless otherwise indicated.
- B. Fasteners: Wood screws, annular threaded nails, self-tapping screws, self-locking rivets and bolts, and other suitable fasteners designed to withstand design loads.
- C. Fastener Types:
1. Blind Rivets: Stainless steel, Series 44. Rivet and mandrel: Stainless steel. Use stainless steel pop rivets for galvanized and pre-finished metals.
 2. Exposed Fasteners: All exposed fasteners to receive metal-jacketed neoprene or EPDM washers.
 - a. Omit washers where fasteners attach counterflashing to receivers, straps to gutters and downspouts to walls.
 - b. Exposed horizontal surface fasteners are unacceptable.
 - c. Other cleats, screws, rivets, bolts, etc.: Matching material to which they attach, or be galvanically compatible to the surface to which they are secured.
 3. Neoprene-Head Screws: #10 or #12 stainless steel screws, with hexagonal heads and matching color metal jacketed neoprene rubber washer.
 4. Stainless Steel Masonry Nailer Washers: EPDM sealing washers bonded to Type 304 stainless steel jackets; Rawl EPDM Sealing Washers, or approved equal; 3/4-inch diameter.
 5. Steel Masonry Nails: Steel pin and zinc-jacketed fastener; Zamac "Hammer Screw," or approved equal. Size: 1/4-inch x 1-1/2 inches.
 6. Roofing Nails:
 - a. Stainless steel or fastening into treated lumber.
 - b. Hot-dipped galvanized or non-ferrous type for fastening into non-treated lumber.
 - c. Provide with annular rings, size as required to suit application; minimum 11-gage with 3/8-inch diameter head.
- D. Miscellaneous Sheet Metal-Related Materials:
1. Lead Drain Flashing: 36" x 36" x 4# sheet lead.
 2. Lead Vent Flashings: 4# sheet lead preformed vent flashing with 4-inch wide roof flange, minimum finished height of 8-inches above roof surface, and minimum 1-inch turn down into top of pipe.
 3. Asphalt Roofing Cement: ASTM D4586, asbestos free, of consistency required for application.
 4. Sealant: One-component, polyether, gun-grade sealant, meeting F.S. TT-S-0230-C, Type II, Class A and ASTM C 920-79; "Sonolastic® 150," by Sonneborn, or "GreatSeal PE-150," by STS Coatings, Inc.

5. Solder: 50% pig lead and 50% black tin, as per ASTM B32.

2.4 FABRICATION, GENERAL

- A. General: Custom fabricate sheet metal flashing and trim to comply with recommendations in SMACNA's "Architectural Sheet Metal Manual" that apply to design, dimensions, geometry, metal thickness, and other characteristics of item indicated. Fabricate items at the shop to greatest extent possible.
- B. Fabricate sheet metal flashing and trim in thickness or weight needed to comply with performance requirements, but not less than that specified for each application and metal.
 1. Obtain field measurements for accurate fit before shop fabrication.
- C. Form sheet metal flashing and trim without excessive oil canning, buckling, and tool marks and true to line and levels indicated, with exposed edges folded back to form hems.
 1. Conceal fasteners and expansion provisions where possible. Exposed fasteners are not allowed on faces exposed to view.
- D. Fabrication Tolerances: Fabricate sheet metal flashing and trim that is capable of installation to tolerances specified in SMACNA.
- E. Sealed Joints: Form non-expansion but movable joints in metal to accommodate elastomeric sealant.
- F. Expansion Provisions: Where lapped expansion provisions cannot be used, form expansion joints of intermeshing hooked flanges, not less than 1-inch deep, filled with elastomeric sealant concealed within joints.
- G. Fabricate cleats and attachment devices from same material as accessory being anchored or from compatible, noncorrosive metal or as shown in the drawings.

2.5 SHEET METAL FABRICATIONS

- A. Galvanized Sheet Metal Items:
 1. Counterflashing and Receivers at Rooftop Units & Exhaust fans:
 - a. Attach receivers as shown in Drawings and noted hereafter.
 - b. Attach counterflashings to receivers with sheet metal screws spaced at 16-inches on centers.
 2. Equipment Curb Caps: All joints fully soldered. Attach to curbs per Drawings.
 3. Flanged Vents: All joints fully soldered.
 - a. Provide with minimum 4-inch wide flange for stripping into new roof assembly.
 - b. Attach flange to substrate wood blocking with stainless steel roofing nails spaced at 3-inches on center, staggered.
 4. Hook Strips: Minimum 22-gauge. Nail at 8-inches on centers, with roofing nails.
 5. Termination Bars: 12-gauge x 1-inch hot-dipped galvanized bar stock fastened with specified drive pins spaced at 12-inches on centers.
 6. Metal Splash Pans: 24-gauge, galvanized steel, formed to shape shown on Drawings.
 7. Downspout Drop: 24-gauge with all joints fully soldered.
- B. Stainless Steel Sheet Metal items:
 1. Receivers at Rooftop Units: where shown on the drawings.
 2. Counterflashings at Rooftop Units: Attach receivers as shown in Drawings and noted hereafter. Attach counterflashings to receivers with sheet metal screws spaced at 16-inches on centers.
 3. Extensions for plumbing vents where shown on the drawings.

4. Thru-Wall Flashing Receiver: Form to shape and secure as shown on Drawings.
- C. Pre-Finished Sheet Metal Items:
1. Copings: Hook at outside face on continuous 22-gauge galvanized cleat. Secure back leg with neoprene-head screws at 12-inches on centers. Provide 1-inch high standing seams at all corners and joints.
 2. Gutters: Fastened at 6-inches on center to substrate wood nailers with stainless steel wood screws.
 - a. Provide 12-gauge x 1-inch galvanized steel straps spaced at 30 inches on centers.
 - b. Straps shall be anchored with stainless steel sheet metal screws to gutter front edge and back face.
 - c. Wrap gutter brackets with 24-gauge prefinished metal.
 3. Edge Metal and Cover Plates: Hook at face on continuous 22-gauge galvanized cleat and nail flange at 3-inches on centers, staggered, with stainless steel roofing nails.
 4. Fascia Metal: Hook at face on continuous 22-gauge galvanized cleat and nail upper flange at 12-inches on centers, with specified roofing nails. Lap joints 3-inches, with concealed sealant pressed between components. Do not rivet or otherwise fix laps.
 5. Downspouts: Transition from downspout to gutter with 24-gauge galvanized fully soldered drops.
 - a. Attach downspouts to masonry walls with 12-gauge x 1-inch galvanized steel straps with two (2) zinc-jacketed masonry drive pins per strap.
 - b. Anchor straps to downspouts with three (3) stainless steel sheet metal screws, 1/2-inch maximum length, per strap. Space straps uniformly at 60-inches on centers and cover each joint in the downspout.
 - c. Extend minimum 2-inches into downspout boots. Wrap straps with prefinished metal.
 6. Counterflashings: (except at Rooftop Units & Exhaust fans): Attach receivers as shown in Drawings and noted hereafter. Attach counterflashings to receivers with sheet metal screws spaced at 16 inches on centers.
 7. Collector Heads: Produce in profiles shown on Drawings. Provide fully sealed joints blind riveted at maximum 2 inches on centers.
 8. Expansion Joint Covers. Hooked on both sides, with standing seam joints.
 9. Expansion Joint Hook Strips (Cleats): Attach with neoprene-head screws spaced at 12-inches on centers.
 10. Wall Panels:
 - a. Type: Shop fabricated preformed panel: 24-gauge "R" panel, 1-1/4-inch nominal height.
 - b. Style: Exposed fastener.
 - c. Texture: Smooth.
 - d. Panel Length: Continuous.

PART 3 - EXECUTION

3.1 EXAMINATION

- A. Examine substrates, areas, and conditions, with Installer present, to verify actual locations, dimensions and other conditions affecting performance of the Work.
 1. Verify compliance with requirements for installation tolerances of substrates.
 2. Verify that substrate is sound, dry, smooth, clean, sloped for drainage, and securely anchored.
- B. Proceed with installation only after unsatisfactory conditions have been corrected.
- C. Coordinate all sheet metal Work with other roofing Work and other trades on this Project with correct sequencing of items making up the entire Project.

3.2 UNDERLAYMENT INSTALLATION

- A. General: Install underlayment as indicated on Drawings.
- B. Self-Adhering Sheet Underlayment:
 - 1. Install self-adhering sheet underlayment, wrinkle free.
 - 2. Apply primer if required by underlayment manufacturer.
 - 3. Comply with temperature restrictions of underlayment manufacturer for installation; use primer rather than nails for installing underlayment at low temperatures.
 - 4. Apply in shingle fashion to shed water, with end laps of not less than 6 inches staggered 24 inches between courses.
 - 5. Overlap side edges not less than 3-1/2 inches.
 - 6. Roll laps with roller.
 - 7. Cover underlayment within 14 days.

3.3 INSTALLATION, GENERAL

- A. General: Anchor sheet metal flashing and trim and other components of the Work securely in place, with provisions for thermal and structural movement. Use fasteners, solder, welding rods, protective coatings, separators, sealants, and other miscellaneous items as required to complete sheet metal flashing and trim system.
 - 1. Install sheet metal flashing and trim true to line and levels indicated. Provide uniform, neat seams with minimum exposure of solder, welds, and sealant.
 - 2. Install sheet metal flashing and trim to fit substrates and to result in watertight performance. Verify shapes and dimensions of surfaces to be covered before fabricating sheet metal.
 - 3. Install exposed sheet metal flashing and trim without excessive oil canning, buckling, and tool marks.
 - 4. Install sealant tape where indicated.
 - 5. Torch cutting of sheet metal flashing and trim is not permitted.
- B. Expansion Provisions: Provide for thermal expansion of exposed flashing and trim. Space movement joints at a maximum of 10 feet with no joints allowed within 24 inches of corner or intersection. Expansion joint covers, expansion breaks or other devices needing these shall be fitted with watertight standing seam joints allowing for lateral expansion as dictated by gauge of metal, "stretch out" or exposure, and latest printed SMACNA guidelines and criteria.
- C. Fastener Sizes: Use fasteners of sizes that will penetrate wood sheathing not less than 1-1/4 inches for nails and not less than 3/4 inch for wood screws.
- D. Seal joints as shown and as required with elastomeric sealant for watertight construction.
 - 1. Where sealant-filled joints are used, embed hooked flanges of joint members not less than 1 inch into sealant. Form joints to completely conceal sealant. When ambient temperature at time of installation is moderate, between 40 and 70 deg F, set joint members for 50 percent movement each way. Adjust setting proportionately for installation at higher ambient temperatures. Do not install sealant-type joints at temperatures below 40 deg F.
- E. Soldered Joints: Clean surfaces to be soldered, removing oils and foreign matter. Pre-tin edges of sheets to be soldered to a width of 1-1/2 inches, except reduce pre-tinning where pre-tinned surface would show in completed Work.
- F. Rivets: Rivet joints connected by stainless steel rivets spaced at 2-inches on center where indicated and where necessary for strength.
- G. All metal flanges, flashings and other metal items in contact with bituminous roof assembly are to

be completely primed with asphalt cut back type primer and, as applicable, set in uniform bed of plastic cement for horizontal surfaces or flashing cement for vertical surfaces. Strip-in metal flanges with specified stripping plies on the same day they are installed.

- H. All joints, other than those receiving standing seam or cover and back plates, in galvanized sheet metal edgings, accessories, flanges and umbrellas, etc. shall be connected by stainless steel blind rivets spaced at 2 inches on center and fully soldered completely watertight.
- I. Fabricate new metal in longest practical lengths up to ten feet, to minimize joints, solder points, welds and seal-offs.
- J. Counter-flashing and receiver joints shall be lapped a minimum of 4 inches and have a ¼-inch bead of sealant pressed between the pieces.
 - 1. The sealant shall not be visible from the exterior.
 - 2. The bottom hemmed edge of the counter-flashing shall be neatly hooked in bayonet fashion.
 - 3. Metal counter-flashings shall completely cover all fasteners used to hold in place top terminations of composition base flashings.
- K. Install all sheet metal flashings and accessories in accordance with the latest printed SMACNA guidelines and in accord with recognized roofing and sheet metal industry standards. Fit flashings tightly in place using square and true mitered corners. Surfaces shall be true and straight and lines accurate to profiles encountered.
- L. Install metal edge securement at fasciae, not including gutters, as tested in accordance with the most current version of the ANSI\SPRI ES-1, "American National Standard for Edge Systems Used with Low-Slope Roofing Systems."
- M. Install new 6-inch wide cover and backer plates at all new edge metal.
 - 1. Fabricate of matching metal and suitable profile to ensure complete and permanent water tight integrity of metal joint.
 - 2. Fasten adjoining 10-foot metal gravel guard sections as per most current SMACNA requirements.
 - 3. New cover plates shall be set in specified sealant. Mastic shall not be used in the jointing of edge metal corners or cover and backer plates.
 - 4. Cover plates shall be neatly bent along the edges to hug the gravel guard over which they are installed. Gaps of more than 1/16 inch are not permitted.
 - 5. Nail edge metal in place not more than 3 inches on centers; in a staggered pattern.
 - 6. Cover plate joints shall be symmetrically laid out so that opposite end sticks of metal are of the same length with all lengths in between being the same. Prepare sample layouts in the field for the Architect's approval prior to proceeding with the Work.

3.4 CLEANING

- A. Clean exposed metal surfaces of substances that interfere with uniform oxidation and weathering.
- B. Clean and neutralize flux materials. Clean off excess solder.
- C. Clean off excess sealants.
- D. Remove temporary protective coverings and strippable films as sheet metal flashing and trim are installed unless otherwise indicated in manufacturer's written installation instructions. On completion of installation, remove unused materials and clean finished surfaces. Maintain in a clean condition during construction.

- E. Do not use touch-up paint to cover any fasteners, metal or other component unless specifically approved in writing in advance of the Work. Any use of touch-up paint without prior approval shall result in affected components being removed and replaced at Contractor's expense.

END OF SECTION 07 6200

SECTION 07 7200 - ROOF ACCESSORIES

PART 1 - GENERAL

1.1 RELATED DOCUMENTS

- A. Drawings and general provisions of the Contract, including General and Supplementary Conditions and other Division 01 through Division 26 Specification Sections, apply to this Section.

1.2 SUMMARY

- A. Section Includes:
 - 1. Roof curbs.
 - 2. Equipment supports.
 - 3. Pipe supports.
- B. Related Sections
 - 1. Section 07 5216 - Modified Bitumen Roof System
 - 2. Section 07 6200 - Flashing and Sheet Metal

1.3 PERFORMANCE REQUIREMENTS

- A. General Performance: Roof accessories shall withstand exposure to weather and resist thermally induced movement without failure, rattling, leaking, or fastener disengagement due to defective manufacture, fabrication, installation, or other defects in construction.

1.4 SUBMITTALS

- A. Product Data: For each type of roof accessory indicated. Include construction details, material descriptions, dimensions of individual components and profiles, and finishes.
- B. Mark each proposed item in product data by circling or highlighting, and affixing the corresponding Article and Paragraph numbers from this Specification. Product data not so marked will be returned without review, for re-submittal.

1.5 PRODUCT DELIVERY, STORAGE, HANDLING AND CONDITIONS

- A. Materials shall be delivered in bulk as necessary so as to provide continuous operations and without hindrance of the Work.
 - 1. Schedule and coordinate with Owner all necessary deliveries so as to cause the least amount of inconvenience to Owner's daily activities.
 - 2. All deliveries and unloading or loading activities shall be the responsibility of the Contractor. The Owner will not take any responsibility for Contractor's deliveries.
- B. Store all necessary materials in such a manner so as to keep from damage by elements or construction and other traffic at all times. Storage of materials on the roof surface is prohibited without adequate blocking to prevent damage to the existing or new roof surfaces.
- C. Fit accessory Work to other Work. Scribe and cope as required for accurate fit.

PART 2 - PRODUCTS

2.1 PIPE SUPPORTS

- A. All piping supported on the roof surfaces shall be one of the following systems, with the hardware for each system being provided by this Contractor. Furnish and install all curbs and flashings, traffic support pads, sheet metal flashings, etc., as required for the proper installation of these systems.
- B. Pipe Supports – Type “A & B”: Provide for support of single condensate lines 1 inch outside diameter and less, and all PVC lines.
1. Space supports at maximum distance of 8'-0" on center or less to prevent sag or deflection.
 2. Place supports within 12 to 18 inches of all “ell” corners, pipe bends, tee intersections and below each pipe or conduit joint.
 3. Manufacturer/Model (Where positive slope is provided in structure / roofing system: OMG “Mini,” or an approved equal.
 4. Manufacturer/Model (Where positive slope is not provided in structure / roofing system: OMG “Height Adjustable Struct OMG Pipe Guard”, or an approved equal.
- C. Pipe Supports – Type “C”: Provide for support of single gas lines / electrical conduit 2 inches outside diameter and less.
1. Space supports at maximum distance of 8'-0" on center or less to prevent sag or deflection.
 2. Space supports at maximum distance of 6'-0" on center or less to prevent sag or deflection where piping or conduit is greater than 1-1/4 inches outside diameter.
 3. Place supports within 12 to 18 inches of all “ell” corners, pipe bends, tee intersections and below each pipe or conduit joint.
 4. Piping or Conduit installation shall provide a minimum clearance of 12” above finished roof surface (New Roof)
 5. Provide retainer bracket to prevent pipe from lifting from the lower rollers.
 6. Manufacturer/Model: Portable Pipe Hanger “PP-10 with Roller,” or an approved equal.
- D. Pipe Supports – Type “D”: Provide for support of single gas lines / electrical conduit greater than 2 inches outside diameter and less than 3-1/2” outside diameter.
1. Space supports at maximum distance of 8'-0" on center or less to prevent sag or deflection.
 2. Place supports within 12 to 18 inches of all “ell” corners, pipe bends, tee intersections and below each pipe or conduit joint.
 3. Piping or Conduit installation shall provide a minimum clearance of 12” above finished roof surface (New Roof)
 4. Manufacturer/Model: Portable Pipe Hanger “PS-1-2,” or an approved equal.
- E. Pipe Supports – Type “E”: Provide for gas piping / electrical conduit in excess of 3-1/2 inches outside diameter.
1. Pipe Roller: Stainless Steel Rods and Axle with Cast Iron Roller and Galvanized Sockets as manufacturer by Cooper B-Line or an approved equal.
 2. Roller support assemblies are to be composed of a steel strut channel with 12-gauge galvanized brackets welded to strut and mounted with galvanized steel bolts through neoprene washers into metal-capped curb assemblies per drawings.
 3. Provide retainer bracket to prevent pipe from lifting from the lower rollers. Install upper and lower rollers so as to not bind pipe and prevent movement.
 4. Space supports at maximum distance of 8'-0" on center or less to prevent sag or deflection.
 5. Place supports within 12 to 18 inches of all “ell” corners, pipe bends, tee intersections and below each pipe or conduit joint.
 6. Elevation of piping / conduit above finished roof surface shall be coordinated with flashing height of associated equipment support curb.

- F. Small Electrical Lines:
1. All electrical lines of less than 1-inch outside diameter shall be placed in a run of galvanized steel Unistrut channel laid across the top of curbs or Type "B" pipe supports
 2. Ends of channels and corners shall be connected with bolted plates.
 3. Secure channels by 16-gauge galvanized steel straps to the curbs or pipe supports.
- G Pipe Support Protection Pad
1. Type A: Provide protection pad below each pipe support base.
 - a. Johns Manville: Modified bitumen cap ply as specified
 - b. Siplast: Modified bitumen cap ply as specified
 - c. Derbigum: Modified bitumen cap ply as specified
 - d. U.S. Ply: Modified bitumen cap ply as specified
 2. Types B, C, D: Provide protection pad below each pipe support base.
 - a. Johns Manville: DynaTred
 - b. Siplast: ParaTread
 - c. Derbigum: Derbicolor XPS FR
 - d. U.S. Ply: USP SBS Walkboard

EQUIPMENT SUPPORTS

- A. Equipment Supports: Internally reinforced metal equipment supports capable of supporting superimposed live and dead loads, including equipment loads and other construction indicated on Drawings.
1. Manufacturer/Model: Thycurb, Inc., Model TEMS-3, or approved equal.
 2. Size: Coordinate dimensions with roughing-in information or Shop Drawings of equipment to be supported.
- B. Construction:
1. Material: Galvanized steel sheet, 18-gauge with welded joints.
 2. Insulation: Fill curb with fiberglass batt insulation.
 3. Factory-installed continuous wood nailers at tops of equipment supports.
 4. Provide a 24-gauge galvanized sheet metal cap with fully soldered or welded joints.
 - a. Secure caps with stainless steel screws with neoprene-head washers spaced at 16-inches on center max., with a minimum of two screws on each side. Curb sides with dimensions of less than 8 inches require one fastener per side.
 5. Fabricate equipment supports to minimum height of 12-inches above the finished roof surface unless otherwise indicated. Top surface of supports shall be level, with height of supports varied to accommodate roof slope.

PART 3 - EXECUTION

3.1 INSTALLATION - GENERAL

- A. Inspect existing conditions to determine that all Work preceding this installation is as intended and is of sound construction. Proceeding with the Work of this Section indicates acceptance of all conditions.
- B. Curbs: Anchor new curbs to existing deck or wood blocking using #12 coated insulation screws or lag bolts spaced at 8 inches on centers, or minimum of two per side.
- C. All installations shall be in accordance with the manufacturer's printed instructions and as shown on the Drawings.

3.2 PIPE SUPPORT INSTALLATION

A. Small Pipe Supports:

1. Assemble small pipe supports with roof walk pad as shown on the Drawings. Adhere supports solid to walk pads in specified sealant.
2. Set pad assemblies on the modified bitumen roof membrane in a solid bed of flashing cement.
3. Securely strap electrical conduit or Unistrut carrying electrical conduit to supports with galvanized steel straps.

B. Roller Assemblies:

1. Anchor new curbs to existing deck or wood blocking using #12 coated insulation screws spaced at 8-inches on center, or a minimum of two per side.
2. Flash curbs to the roof per the respective Section.
3. Set new galvanized metal caps as shown on the Drawings.
4. Set new roller assemblies and anchor securely to curbs with neoprene-head screws.
5. Strap tops of pipes to roller assemblies.

C. Equipment Supports and Curbs: Anchor new curbs to existing deck or wood blocking as shown on the drawings using #12 coated insulation screws or lag bolts spaced at 8-inches on centers, or minimum of two per side.

D. Other Assemblies: Install as indicated on the Drawings or as designated above.

3.3 CLEANING

- #### A. Clean all items of this Section in accordance with the respective manufacturer's instructions.

END OF SECTION 07 7200

SECTION 07 9100 - JOINT SEALERS

PART 1 - GENERAL

1.1 RELATED DOCUMENTS

- A. Drawings and general provisions of the Contract, including General and Supplementary Conditions and other Division 01 through Division 26 Specification Sections, apply to this Section.

1.2 SUMMARY

- A. Section Includes:
 - 1. Urethane sealant.
 - 2. Polyethylene backer rod.
- B. Related Sections
 - 1. Section 04 5100 - Masonry Cleaning and Waterproofing

1.3 REFERENCES

- A. ASTM C-920, Type S, Grade NS, Class 25
- B. ASTM C-920-79.
- C. ASTM D412 - Test Methods for Rubber Properties in Tension.
- D. ASTM D1056 - Flexible Cellular Materials - Sponge or Expanded Rubber.
- E. FS TT-S-00230-C, Type II, Class A - Sealing Compound Silicone, Single Component
- F. ASTM C639 - Standard Test Method for Rheological (Flow) Properties of Elastomeric Sealants.
- G. ASTM C794 - Standard Test Method for Adhesion-in-Peel of Elastomeric Joint Sealants.
- H. ASTM C920 - Elastomeric Joint Sealants.
- I. ASTM C1193 - Standard Guide for Use of Joint Sealants.
- J. ASTM C1330 - Cylindrical Sealant Backing for Use with Cold Liquid Applied Sealants.
- K. ASTM D412 - Standard Test Method for Vulcanized Rubber and Thermoplastic Rubbers and Thermoplastic Elastomers - Tension.
- L. ASTM D624 - Standard Test Method for Tear Strength of Conventional Vulcanized Rubber and Thermoplastic Elastomers.
- M. ASTM D2240 - Rubber Property Durometer Hardness.

1.4 SUBMITTALS

- A. Comply with provisions of the appropriate Division 1 Section.

- B. Submit manufacturer's literature and letters attesting that the products proposed meet or exceed these Specifications.
- C. Samples.
 - 1. Provide 24-inch long sample in the field of each sealant type for the Architect's approval. Each sample shall be marked and remain in place throughout the project and will be gauged as the standard by which all other work will be judged.

1.5 PRODUCT HANDLING

- A. Deliver products in manufacturer's original containers clearly labeled with product identification, date of manufacture, and shelf life.
- B. Store materials in clean, dry area at temperatures below [86 degrees F.] [30 degrees C.]
- C. Do not use sealants and primers after manufacturer's stated shelf life.

1.6 ENVIRONMENTAL CONDITIONS

- A. Weather Conditions. Do not proceed with installation of liquid sealants under unfavorable or wet weather conditions
- B. Temperature Range: Install elastomeric sealants when temperature is in lower third of temperature range recommended by manufacturer for installation.

1.7 WARRANTY

- A. Provide two (2) year warranty covering defects in labor and materials for all sealants installed under this contract.
- B. Warranty shall cover complete replacement of sealant which fails due to loss of cohesion or adhesion or does not cure.

PART 2 - PRODUCTS

2.1 MATERIALS

- A. General Sealant Performance Requirements: Colors to be selected by the Architect from manufacturer's standard colors. Select materials for compatibility with joint surfaces and other indicated exposures and, except as otherwise indicated, select modulus of elasticity and hardness of grade recommended by manufacturer for each application indicated.
- B. Masonry Control Joint Sealant: "Sonneborn NP-2," by BASF Corp, or an approved equal. Two component urethane gun-grade sealant meeting F.S. TT-S-00230-C, Type II, Class A and ASTM C-920-79.

2.2 RELATED MATERIALS

- A. Primer. Non-staining type, recommended by sealant Manufacturer to suit applications as found under this contract.
- B. Joint Cleaner. Non-corrosive and non-staining type, recommended by sealant Manufacturer, compatible with joint forming materials.

- C. Joint Filler. ASTM D1056; round, closed cell polyethylene foam rod; oversized 30% to 50%.
- D. Bond Breaker. Pressure sensitive tape recommended by sealant manufacturer to suit applications.
- E. Masking tape: Non-staining, non-absorbent type compatible with silicone sealant and adjacent surfaces.

PART 3 - EXECUTION

3.1 MANUFACTURER'S INSTRUCTIONS

- A. Comply with Manufacturer's latest printed instructions except where more stringent requirements are shown or specified, and except where Manufacturer's technical representative directs otherwise.

3.2 PREPARATION

- A. Review the Contract Documents to determine and locate all Work required by this Section and the Work of any other trade which affects the Work of this Section.
- B. Remove existing sealants and backer rod to substrate surfaces. Clean joint surfaces immediately before installation of sealant or caulking compound. Remove dirt, insecure coatings, moisture and other substances which would interfere with bond of sealant or caulking compound.
- C. Prime or seal joint surfaces where indicated, and where recommended by sealant manufacturer. Do not allow primer/sealer to spill or migrate onto adjoining surfaces.
- D. Examine joint dimensions and size materials to achieve required width/depth ratio.

3.3 INSTALLATION

- A. Replace all sealant and backer rod at existing masonry control joints and other sealant joints where shown on the drawings.
- B. Set joint filler units at proper width to depth ratio, or as shown on the Drawings, or position in joint to coordinate with other work, including installation of bond breakers, backer rods and sealants. Do not leave voids or gaps between ends of joint filler units.
- C. Install sealant backer rod for liquid elastomeric sealants, except where shown to be omitted or recommended to be omitted by sealant manufacturer for application indicated.
- D. Install bond breaker tape where indicated and where required by manufacturer's recommendations to ensure that elastomeric sealants will perform properly.
- E. Employ only proven installation techniques, which will ensure that sealants are deposited in uniform, continuous ribbons without gaps or air pockets, with complete "wetting" of joint bond surfaces equally on opposite sides. Except as otherwise indicated, fill sealant rabbet to a slightly concave surface, slightly below adjoining surfaces. Where horizontal joints are between a horizontal surface and vertical surface, fill joint to form a slight cove, so that joint will not trap moisture and dirt.

- F. Fill joint solidly with new sealant. Where mortar has not reached the proper depth fill with backer rod as required.
- G. For normal moving joints sealed with elastomeric sealants fill joints to a depth equal to 50% of joint width, but neither more than ½-inch deep nor less than 3/8-inch deep. Control shall be exercised to ensure the proper width to depth ratio recommended by the sealant manufacturer.
- H. Do not allow sealants or compounds to overflow or spill onto adjoining surfaces, or to migrate into voids of adjoining surfaces. Clean adjoining surfaces by whatever means may be necessary to eliminate evidence of spillage
- I. Rake joints to provide slightly convex finish.

3.4 FIELD QUALITY CONTROL

- A. Perform adhesion tests in accordance with manufacturer's instructions and ASTM C1193, Method A, Field-Applied Sealant Joint Hand-Pull Tab.
- B. Sealants failing adhesion test shall be removed, substrates cleaned, sealants re-installed, and re-testing performed.
- C. Maintain test log and submit report to Owner indicating tests, locations, dates, results, and remedial actions.

3.5 CURE AND PROTECTION

Cure sealants and caulking compounds in compliance with manufacturer's instructions and recommendations, to obtain high early bond strength, internal cohesive strength and surface durability. Advise the Architect of procedures required for cure and protection of joint sealers during construction period, so that they will be without deterioration or damage (other than normal wear and weathering) at time of Substantial Completion.

END OF SECTION 07 9100

SECTION 22 0529 - HANGERS AND SUPPORTS

PART 1 - GENERAL

1.1 RELATED DOCUMENTS

- A. Drawings and general provisions of the Contract, including General and Supplementary Conditions and other Division 01 through Division 26 Specification Sections, apply to this Section.

1.2 SUMMARY

- A. Section Includes:
 - 1. Hangers and Support for Plumbing Piping and Equipment as specified herein.
 - 2. Accessory devices and equipment as required and/or as indicated to insure proper operating system.
- B. Related Sections
 - 1. Section 22 1413 - Facility Storm Drainage Piping
 - 2. Section 22 1426 - Roof Drains

1.3 QUALITY ASSURANCE

- A. The installation of Hangers and Support for Plumbing Piping and Equipment shall be performed by an experienced Contractor using materials produced by reputable manufacturers. This installation shall be in strict accordance with the State and Local Codes, as well as with the published standards of the manufacturers of the materials.

1.4 SUBMITTALS

- A. Submit product data for all components to be used on the Project.
- B. Mark each proposed item in product data by circling or highlighting, and affix the corresponding Article and Paragraph designations from this Specification Section. Product data not so marked will be returned without review, for re-submittal complying with the above requirements.

1.6 DELIVERY, STORAGE AND HANDLING

- A. Cover and protect material in transit and at site. Material not properly protected and stored which is damaged or defaced during construction shall and will be rejected.
- B. Store materials in designated areas, out of the way of Owner's on-going operations.

PART 2 - PRODUCTS

2.1 PIPE HANGERS

- A. Pipe hangers shall be of a type suitable for each use. Perforated straps shall not be used in any work. For ferrous pipes up to and including four inches (4") in size malleable iron, adjustable, split ring, swivel hanger. For plumbing piping larger than four inches (4"), use steel clevis hanger. Where several pipes are parallel at the same elevation, trapeze hangers may be used. Where trapeze hangers are used, the pipes shall be supported on rollers. For copper pipes up to and

including three inches (3") in size, use malleable iron, copper plated hangers. For copper pipes larger than three inches (3"), use copper-plated clevis hanger.

- B. All hanger rods shall be double nutted. Hanger rod sizes shall conform to the following schedule:

Pipe up to and including 2"	3/8" rods
Pipe 2 1/2", 3" and 3 1/2"	1/2" rods
Pipe 4" and 5"	5/8" rods
Pipe 6"	3/4" rods

- C. Unless otherwise shown on the Plans, all horizontal runs of ferrous piping shall be suspended from the floor or roof construction, as the case may be, by means of hangers with the following maximum spacing:

Pipe up to and including 1 1/4"	8 feet
Pipe 1 1/2" and 2"	10 feet
Pipe 2 1/2" and 3"	12 feet
Pipe 3 1/2" and 4"	14 feet
Pipe 5" and 6"	16 feet

- D. Unless shown otherwise on the Plans, all horizontal runs of copper piping shall be suspended from the floor or roof construction, as the case may be, by means of hangers with the following maximum spacing:

Pipe up to 3/4" in size	5 feet
Pipe 1" and 1 1/4"	8 feet
Pipe 1 1/2" and larger	10 feet

- E. There shall be a hanger within two feet (2') of each elbow or tee. Additional supports shall be provided for valves, strainers, etc. Cast iron pipe shall have not less than one hanger per length of pipe. Vertical risers shall be supported by approved riser clamps. Vertical pipes within a space shall have not less than two (2) supports.
- F. Supports and hangers shall be installed to permit free expansion and contraction in the piping systems. Hangers shall permit vertical adjustment to maintain proper pitch. Where necessary to control expansion and contraction, the piping shall be guided and firmly anchored. No piping shall be self-supporting; nor shall it be supported from equipment connections.
- G. Inserts shall be used where piping or equipment is to be hung from concrete construction. Inserts shall be wedge type, concrete inserts. All inserts shall be pretreated to prevent rusting. After the forms are removed, clip off all nails flush with the exposed surface of the inserts.
- H. Expansion bolts shall be Ackerman-Johnson.
- I. Beam clamps suitable for use with the type of steel construction involved shall be Grinnell.
- J. All chilled water, domestic cold water piping, horizontal downspouts, where applicable, condensate drain piping, and soil piping receiving cold condensate shall have hangers sized to go around the insulation with saddles being provided to protect the insulation.

- K. Manufacturers: Subject to compliance with requirements, provide products by one of the following:
1. Pipe Hangers:
 - a. B-Line Systems, Inc.
 - b. Grinnell Corp.
 - c. GS Metals Corp.
 - d. PHD Manufacturing, Inc.
 - e. PHS Industries, Inc.
 - f. Piping Technology & Products, Inc.
 2. Channel Support Systems:
 - a. B-Line Systems, Inc.
 - b. Grinnell Corp.; Power-Strut Unit.
 - c. Unistrut Corp.
 3. Thermal-Hanger Shield Inserts:
 - a. PHS Industries, Inc.
 - b. Pipe Shields, Inc.
 - c. Rilco Manufacturing Co., Inc.

2.2 MANUFACTURED UNITS

- A. Pipe Hangers, Supports, and Components. Refer to "Hanger and Support Applications" Article in Part 3 for where to use specific hanger and support types.
1. Galvanized, Metallic Coatings: For piping and equipment that will not have field-applied finish.
 2. Nonmetallic Coatings: On attachments for electrolytic protection where attachments are in direct contact with copper tubing.
- B. Channel Support Systems: factory-fabricated components for field assembly.
1. Coatings: Manufacturer's standard finish, unless bare metal surfaces are indicated.
 2. Nonmetallic Coatings: On attachments for electrolytic protection where attachments are in direct contact with copper tubing.
- C. Thermal-Hanger Shield Inserts: 100-psi (690-kPa) minimum compressive-strength insulation, encased in sheet metal shield.
1. Material for Insulated Piping: ASTM, Type I cellular glass or water-repellent-treated, ASTM, Type I calcium silicate.
 2. For Trapeze or Clamped System: Insert and shield cover entire circumference of pipe.
 3. For Clevis or Band Hanger: Insert and shield cover lower 180 degrees of pipe.
 4. Insert Length: Extend 2 inches (50 mm) beyond sheet metal shield for piping operating below ambient air temperature.

2.3 MISCELLANEOUS MATERIALS:

- A. Structural Steel: ASTM steel plates, shapes, and bars, black and galvanized. All exterior pipe support systems shall be zinc rich hot dip galvanized.
- B. Grout: ASTM, Grade B, factory-mixed and packaged, nonshrink and nonmetallic, dry, hydraulic-cement grout.
- C. Characteristics: Post hardening and volume adjusting; recommended for both interior and exterior applications.
- D. Properties: Non-staining, non-corrosive, and non-gaseous.
- E. Design Mix: 5000-psi (34.5-MPa), 28-day compressive strength.

PART 3 - EXECUTION

3.1 HANGER AND SUPPORT APPLICATIONS:

- A. Hangers for all insulated pipe shall be oversized accordingly to accommodate the outside diameter of the insulation.
- B. Specific hanger requirements are specified in Sections specifying equipment and systems.
- C. Comply with MSS for pipe hanger selections and applications that are not specified in piping system Specification Sections.
- D. Horizontal-Piping Hangers and Supports: Unless otherwise indicated and except as specified in piping system Specification Sections, install the following types:
 - 1. Adjustable Steel Clevis Hangers: For suspension of non-insulated or insulated stationary pipes, NPS 1/2 to NPS 30 (DN15 to DN750).
 - 2. Yoke-Type Pipe Clamps: For suspension of 120 to 450 degrees F (49 to 232 degrees C) pipes, NPS 4 to NPS 16 (DN100 to DN400), requiring up to 4 inches (100 mm) of insulation.
 - 3. Carbon- or Alloy-Steel, Double-Bolt Pipe Clamps: For suspension of pipes, NPS 3/4 to NPS 24 (DN20 to DN600), requiring clamp flexibility and up to 4 inches (100 mm) of insulation.
 - 4. Steel Pipe Clamps: For suspension of cold and hot pipes, NPS 1/2 to NPS 24 (DN15 to DN600), if little or no insulation is required.
 - 5. Pipe Hangers: For suspension of pipes, NPS 1/2 to NPS 4 (DN15 to DN100), to allow off-center closure for hanger installation before pipe erection.
 - 6. Adjustable Swivel Split- or Solid-Ring Hangers: For suspension of non-insulated stationary pipes, NPS 3/4 to NPS 8 (DN20 to DN200).
 - 7. Adjustable Steel Band Hangers: For suspension of non-insulated stationary pipes, NPS 1/2 to NPS 8 (DN15 to DN200).
 - 8. Adjustable Band Hangers: For suspension of non-insulated stationary pipes, NPS 1/2 to NPS 8 (DN15 to DN200).
 - 9. Adjustable Swivel-Ring Band Hangers: For suspension of non-insulated stationary pipes, NPS 1/2 to NPS 2 (DN15 to DN50).
 - 10. Split Pipe-Ring with or without Turnbuckle-Adjustment Hangers: For suspension of non-insulated stationary pipes, NPS 3/8 to NPS 8 (DN10 to DN200).
 - 11. Extension Hinged or Two-Bolt Split Pipe Clamps: For suspension of non-insulated stationary pipes, NPS 3/8 to NPS 3 (DN10 to DN80).
 - 12. U-Bolts: For support of heavy pipe, NPS 1/2 to NPS 30 (DN15 to DN750).
 - 13. Clips: For support of insulated pipes not subject to expansion or contraction.
 - 14. Pipe Saddle Supports: For support of pipes, NPS 4 to NPS 36 (DN100 to DN900), with steel pipe base stanchion support and cast-iron floor flange.
 - 15. Pipe Stanchion Saddles: For support of pipes, NPS 4 to NPS 36 (DN100 to DN900), with steel pipe base stanchion support and cast-iron floor flange and with U-bolt to retain pipe.
 - 16. Adjustable Pipe Saddle Supports: For stanchion-type support for pipes, NPS 2-1/2 to NPS 36 (DN65 to DN900), if vertical adjustment is required, with steel pipe base stanchion support and cast-iron floor flange.
 - 17. Single Pipe Rolls: For suspension of pipes, NPS 1 to NPS 30 (DN25 to DN750), from two rods if longitudinal movement caused by expansion and contraction might occur.
 - 18. Adjustable Roller Hangers: For suspension of pipes, NPS 2-1/2 to NPS 20 (DN65 to DN500), from single rod if horizontal movement caused by expansion and contraction might occur.

19. Complete Pipe Rolls: For support of pipes, NPS 2 to NPS 42 (DN50 to DN1050), if longitudinal movement caused by expansion and contraction might occur but vertical adjustment is not necessary.
 20. Pipe Roll and Plate Units: For support of pipes, NPS 2 to NPS 24 (DN50 to DN600), if small horizontal movement caused by expansion and contraction might occur and vertical adjustment is not necessary.
 21. Adjustable Pipe Roll and Base Units: For support of pipes, NPS 2 to NPS 30 (DN50 to DN750), if vertical and lateral adjustment during installation might be required in addition to expansion and contraction.
- E. Vertical-Piping Clamps: Unless otherwise indicated and except as specified in piping system Specification Sections, install the following types:
1. Extension Pipe or Riser Clamps: For support of pipe risers, NPS 3/4 to NPS 20 (DN20 to DN500).
 2. Carbon- or Alloy-Steel Riser Clamps: For support of pipe risers, NPS 3/4 to NPS 20 (DN20 to DN500), if longer ends are required for riser clamps.
- F. Hanger-Rod Attachments: Unless otherwise indicated and except as specified in piping system Specification Sections, install the following types:
1. Steel Turnbuckles: For adjustment up to 6 inches (150 mm) for heavy loads.
 2. Steel Clevises: For 120 to 450 degrees F (49 to 232 degrees C) piping installations.
 3. Swivel Turnbuckles: For use with MSS Type 11, split pipe rings.
 4. Malleable-Iron Sockets: For attaching hanger rods to various types of building attachments.
 5. Steel Weldless Eye Nuts: For 120 to 450 degrees F (49 to 232 degrees C) piping installations.
- G. Building Attachments: Unless otherwise indicated and except as specified in piping system Specification Sections, install the following types:
1. Steel or Malleable Concrete Inserts: For upper attachment to suspend pipe hangers from concrete ceiling.
 2. Top-Beam C-Clamps: For use under roof installations with bar-joist construction to attach to top flange of structural shape.
 3. Side-Beam or Channel Clamps: For attaching to bottom flange of beams, channels, or angles.
 4. Center-Beam Clamps: For attaching to center of bottom flange of beams.
 5. Welded Beam Attachments: For attaching to bottom of beams if loads are considerable and rod sizes are large.
 6. C-Clamps: For structural shapes.
 7. Top-Beam Clamps For top of beams if hanger rod is required tangent to flange edge.
 8. Side-Beam Clamps For bottom of steel I-beams.
 9. Steel-Beam Clamps with Eye Nuts: For attaching to bottom of steel I-beams for heavy loads.
 10. Linked-Steel Clamps with Eye Nuts: For attaching to bottom of steel I-beams for heavy loads, with link extensions.
 11. Malleable Beam Clamps with Extension Pieces: For attaching to structural steel.
 12. Welded-Steel Brackets: For support of pipes from below or for suspending from above by using clip and rod. Use one of the following for indicated loads:
 - a. Light: 750 lb (340 kg).
 - b. Medium: 1500 lb (675 kg).
 - c. Heavy: 3000 lb (1350 kg).
 13. Side-Beam Brackets: For sides of steel or wooden beams.
 14. Plate Lugs: For attaching to steel beams if flexibility at beam is required.

15. Horizontal Travelers: For supporting piping systems subject to linear horizontal movement where head room is limited.
- H. Saddles and Shields: Unless otherwise indicated and except as specified in piping system Specification Sections, install the following types:
1. Steel Pipe-Covering Protection Saddles: To fill interior voids with insulation that matches adjoining insulation.
 2. Protection Shields: Of length recommended by manufacturer to prevent crushing insulation.
 3. Thermal-Hanger Shield Inserts: For supporting insulated pipe, 360-degree insert of high-density, 100-psi (690-kPa) minimum compressive-strength, water-repellent-treated calcium silicate or cellular-glass pipe insulation, same thickness as adjoining insulation with vapor barrier and encased in 360-degree sheet metal shield.
- I. Spring Hangers and Supports: Unless otherwise indicated and except as specified in piping system Specification Sections, install the following types:
1. Restraint-Control Devices: Where indicated to control piping movement.
 2. Spring Cushions: For light loads if vertical movement does not exceed 1-1/4 inches (32 mm).
 3. Spring-Cushion Roll Hangers: For equipping Type 41 roll hanger with springs.
 4. Spring Sway Braces: To retard sway, shock, vibration, or thermal expansion in piping systems.
 5. Variable-Spring Hangers: Preset to indicated load and limit variability factor to 25 percent to absorb expansion and contraction of piping system from hanger.
 6. Variable-Spring Base Supports: Preset to indicated load and limit variability factor to 25 percent to absorb expansion and contraction of piping system from base support.
 7. Variable-Spring Trapeze Hangers: Preset to indicated load and limit variability factor to 25 percent to absorb expansion and contraction of piping system from trapeze support.
 8. Constant Supports: For critical piping stress and if necessary to avoid transfer of stress from one support to another support, critical terminal, or connected equipment. Include auxiliary stops for erection, hydrostatic test, and load-adjustment capability. These supports include the following types:
 - a. Horizontal: Mounted horizontally.
 - b. Vertical: Mounted vertically.
 - c. Trapeze: Two vertical-type supports and one trapeze member.

3.2 HANGER AND SUPPORT INSTALLATION

- A. Pipe Hanger and Support Installation: Comply with MSS Standards. Install hangers, supports, clamps, and attachments as required to properly support piping from building structure.
- B. Channel Support System Installation: Arrange for grouping of parallel runs of piping and support together on field-assembled channel systems.
1. Field assemble and install according to manufacturer's written instructions.
- C. Heavy-Duty Steel Trapeze Installation: Arrange for grouping of parallel runs of horizontal piping and support together on field-fabricated, heavy-duty trapezes.
1. Pipes of Various Sizes: Support together and space trapezes for smallest pipe size or install intermediate supports for smaller diameter pipes as specified above for individual pipe hangers.
 2. Field fabricate from Standards, steel shapes selected for loads being supported. Weld steel according to AWS Standards.
- D. Install building attachments within concrete slabs or attach to structural steel. Space attachments within maximum piping span length indicated in MSS. Install additional attachments at

concentrated loads, including valves, flanges, guides, strainers, and expansion joints, and at changes in direction of piping. Install concrete inserts before concrete is placed; fasten inserts to forms and install reinforcing bars through openings at top of inserts.

- E. Install hangers and supports complete with necessary inserts, bolts, rods, nuts, washers, and other accessories.
 - F. Install hangers and supports to allow controlled thermal and seismic movement of piping systems, to permit freedom of movement between pipe anchors, and to facilitate action of expansion joints, expansion loops, expansion bends, and similar units.
 - G. Load Distribution: Install hangers and supports so that piping live and dead loads and stresses from movement will not be transmitted to connected equipment.
 - H. Pipe Slopes: Install hangers and supports to provide indicated pipe slopes and so maximum pipe deflections allowed by ASME Standards, is not exceeded.
 - I. Insulated Piping: Comply with the following:
 - 1. Attach clamps and spacers to piping.
 - a. All Insulated Piping: Use thermal-hanger shield insert with clamp sized to match OD of insert.
 - b. Do not exceed pipe stress limits according to ASME Standards.
 - 2. Install MSS protection saddles, if insulation without vapor barrier is indicated. Fill interior voids with insulation that matches adjoining insulation.
 - a. Option: Thermal-hanger shield inserts may be used. Include steel weight-distribution plate for pipe NPS 4 (DN100) and larger if pipe is installed on rollers.
 - J. Install MSS SP-58, Type 40 protective shields on cold piping with vapor barrier. Shields shall span arc of 180 degrees.
 - 1. Option: Thermal-hanger shield inserts may be used. Include steel weight-distribution plate for pipe NPS 4 (DN100) and larger if pipe is installed on rollers.
 - K. Shield Dimensions for Pipe: Not less than the following:
 - 1. NPS 1/4 to NPS 3-1/2 (DN8 to DN90): 12 inches (305 mm) long and 0.048 inch (1.22 mm) thick.
 - 2. NPS 4 (DN100): 12 inches (305 mm) long and 0.06 inch (1.52 mm) thick.
 - 3. NPS 5 and NPS 6 (DN125 and DN150): 18 inches (457 mm) long and 0.06 inch (1.52 mm) thick.
 - 4. NPS 8 to NPS 14 (DN200 to DN350): 24 inches (610 mm) long and 0.075 inch (1.91 mm) thick.
 - 5. NPS 16 to NPS 24 (DN400 to DN600): 24 inches (610 mm) long and 0.105 inch (2.67 mm) thick.
 - L. Pipes NPS 8 (DN200) and Larger: Include wood inserts.
 - M. Insert Material: Length at least as long as protective shield.
 - N. Thermal-Hanger Shields: Install with insulation same thickness as piping insulation.
- 3.3 EQUIPMENT SUPPORTS
- A. Fabricate structural-steel stands to suspend equipment from structure above or to support equipment above floor.

- B. Grouting: Place grout under supports for equipment and make smooth bearing surface.

3.4 METAL FABRICATION

- A. Cut, drill, and fit miscellaneous metal fabrications for heavy-duty steel trapezes and equipment supports.
- B. Fit exposed connections together to form hairline joints. Field-weld connections that cannot be shop-welded because of shipping size limitations.
- C. Field Welding: Comply with AWS procedures for shielded metal arc welding, appearance and quality of welds, and methods used in correcting welding work, and with the following:
 - 1. Use materials and methods that minimize distortion and develop strength and corrosion resistance of base metals.
 - 2. Obtain fusion without undercut or overlap.
 - 3. Remove welding flux immediately.
 - 4. Finish welds at exposed connections so no roughness shows after finishing and contours of welded surfaces match adjacent contours.

3.5 ADJUSTING:

- A. Hanger Adjustment: Adjust hangers to distribute loads equally on attachments and to achieve indicated slope of pipe.

3.6 PAINTING:

- A. Touching Up: Clean field welds and abraded areas of shop paint. Paint exposed areas immediately after erecting hangers and supports. Use same materials as used for shop painting. Comply with SSPC-SP2 requirements for touching up field-painted surfaces.
 - 1. Apply paint by brush or spray to provide:
 - a. Wet mil thickness: 6.0 mils minimum to 10 mils maximum.
 - b. Dry mil thickness: 2.5 mils minimum to 4.0 mils maximum.
 - c. Coverage: 154 square feet per gallon minimum to 247 square feet per gallon maximum.
- B. Galvanized Surfaces: Clean welds, bolted connections, and abraded areas and apply galvanizing-repair paint to comply with ASTM Standards.

END OF SECTION 22 0529

SECTION 22 1413 - FACILITY STORM DRAINAGE PIPING

PART 1 - GENERAL

1.1 RELATED DOCUMENTS

- A. Drawings and general provisions of the Contract, including General and Supplementary Conditions and other Division 01 through Division 26 Specification Sections, apply to this Section.

1.2 SUMMARY

- A. Section Includes:
 - 1. Facility Storm Drainage Piping as specified herein.
 - 2. Accessory devices and equipment as required and/or as indicated to insure proper operating system.
- B. Related Sections
 - 1. Section 22 0529 - Hangers and Supports
 - 2. Section 22 1426 - Roof Drains

1.3 QUALITY ASSURANCE

- A. The installation of Facility Storm Drainage Piping shall be performed by an experienced Contractor using materials produced by reputable manufacturers. This installation shall be in strict accordance with the State and Local Codes, as well as with the published standards of the manufacturers of the materials.

1.4 SUBMITTALS

- A. Submit product data for all components to be used on the Project.
- B. Mark each proposed item in product data by circling or highlighting, and affix the corresponding Article and Paragraph designations from this Specification Section. Product data not so marked will be returned without review, for re-submittal complying with the above requirements.

1.6 DELIVERY, STORAGE AND HANDLING

- A. Cover and protect material in transit and at site. Material not properly protected and stored which is damaged or defaced during construction shall and will be rejected.
- B. Store materials in designated areas, out of the way of Owner's on-going operations.

PART 2 - PRODUCTS

2.1 PVC STORM DRAINAGE PIPING AND ACCESSORIES

- A. PVC, Schedule 40 Pipe: ASTM D 1785.
- B. PVC, Schedule 40 Socket Fittings: ASTM D 2466.
- C. Fire Resistant Wrap: 3M Fire Barrier Plenum Wrap 5A, Thermal Ceramics PlenumWrap, or approved equivalent.

PART 3 - EXECUTION

3.1 PIPING INSTALLATION

- A. Install wall penetration system at each service pipe penetration through exterior wall. Make installation watertight.
- B. Make changes in direction for storm drainage piping using appropriate branches, bends, and long-sweep bends. Do not change direction of flow more than 90 degrees. Use proper size of standard increasers and reducers if pipes of different sizes are connected. Reducing size of drainage piping in direction of flow is prohibited.
- C. Install storm drainage piping at the following minimum slopes, unless otherwise indicated:
 - 1. All Horizontal Storm Drainage Piping: 1 percent downward in direction of flow.
- D. Do not enclose, cover, or put piping into operation until it is inspected and approved by authorities having jurisdiction.

3.2 JOINT CONSTRUCTION

- A. PVC Non-pressure Piping Joints: Join piping according to ASTM D 2665.

3.3 HANGER AND SUPPORT INSTALLATION

- A. Refer to Section 22 05 29 "Hangers and Supports" for pipe hanger and support devices. Install the following:
 - 1. Vertical Piping: Riser clamps.
 - 2. Individual, Straight, Horizontal Piping Runs: According to the following:
 - a. 100 Feet (30 m) and Less: MSS Type 1, adjustable, steel clevis hangers.
 - b. Longer Than 100 Feet (30 m): MSS Type 43, adjustable roller hangers.
 - c. Longer Than 100 Feet (30 m), if Indicated: MSS Type 49, spring cushion rolls.
 - 3. Multiple, Straight, Horizontal Piping Runs 100 Feet (30 m) or Longer: MSS Type 44, pipe rolls. Support pipe rolls on trapeze.
 - 4. Base of Vertical Piping: MSS Type 52, spring hangers.
- B. Install supports according to Section 22 05 29 "Hangers and Supports."
- C. Support vertical piping and tubing at base and at each floor.
- D. Rod diameter may be reduced 1 size for double-rod hangers, with 3/8-inch (10-mm) minimum rods.
- E. Install hangers for horizontal storm drainage piping with the following maximum horizontal spacing and minimum rod diameters:
 - 1. NPS 1-1/2 and NPS 2 (DN 40 and DN 50): 60 inches (1500 mm) with 3/8-inch (10-mm) rod.
 - 2. NPS 3 (DN 80): 60 inches (1500 mm) with 1/2-inch (13-mm) rod.
 - 3. NPS 4 and NPS 5 (DN 100 and DN 125): 60 inches (1500 mm) with 5/8-inch (16-mm) rod.
 - 4. NPS 6 (DN 150): 60 inches (1500 mm) with 3/4-inch (19-mm) rod.
 - 5. NPS 8 to NPS 12 (DN 200 to DN 300): 60 inches (1500 mm) with 7/8-inch (22-mm) rod.
 - 6. Spacing for 10-foot (3-m) lengths may be increased to 10 feet (3 m). Spacing for fittings is limited to 60 inches (1500 mm).
- F. Install supports for vertical storm drainage piping every 15 feet (4.5 m).

3.4 CONNECTIONS

- A. Drawings indicate general arrangement of piping, fittings, and specialties.
- B. Connect storm drainage piping to exterior storm drainage piping. Use transition fitting to join dissimilar piping materials.
- C. Connect storm drainage piping to roof drains and storm drainage specialties.

3.5 FIELD QUALITY CONTROL

- A. During installation, notify authorities having jurisdiction at least 24 hours before inspection must be made. Perform tests specified below in presence of authorities having jurisdiction.
 - 1. Roughing-in Inspection: Arrange for inspection of piping before concealing or closing-in after roughing-in and before setting fixtures.
 - 2. Final Inspection: Arrange for final inspection by authorities having jurisdiction to observe tests specified below and to ensure compliance with requirements.
- B. Reinspection: If authorities having jurisdiction find that piping will not pass test or inspection, make required corrections and arrange for reinspection.
- C. Reports: Prepare inspection reports and have them signed by authorities having jurisdiction.
- D. Test storm drainage piping according to procedures of authorities having jurisdiction or, in absence of published procedures, as follows:
 - 1. Test for leaks and defects in new piping and parts of existing piping that have been altered, extended, or repaired. If testing is performed in segments, submit separate report for each test, complete with diagram of portion of piping tested.
 - 2. Leave uncovered and unconcealed new, altered, extended, or replaced storm drainage piping until it has been tested and approved. Expose work that was covered or concealed before it was tested.
 - 3. Test Procedure: Test storm drainage piping on completion of roughing-in. Close openings in piping system and fill with water to point of overflow, but not less than 10-foot head of water (30 kPa). From 15 minutes before inspection starts to completion of inspection, water level must not drop. Inspect joints for leaks.
 - 4. Repair leaks and defects with new materials and retest piping, or portion thereof, until satisfactory results are obtained.
 - 5. Prepare reports for tests and required corrective action.

3.6 CLEANING

- A. Clean interior of piping. Remove dirt and debris as work progresses. Protect drains during remainder of construction period to avoid clogging with dirt and debris and to prevent damage from traffic and construction work.
- B. Place plugs in ends of uncompleted piping at end of day and when work stops.

END OF SECTION 22 1413

SECTION 22 1426 – ROOF DRAINS

PART 1 - GENERAL

1.1 RELATED DOCUMENTS

- A. Drawings and general provisions of the Contract, including General and Supplementary Conditions and other Division 01 through Division 26 Specification Sections, apply to this Section.

1.2 SUMMARY

- A. Section Includes:
 - 1. Facility Storm Drainage Piping as specified herein.
 - 2. Accessory devices and equipment as required and/or as indicated to insure proper operating system.
- B. Related Sections
 - 1. Section 22 0529 - Hangers and Supports
 - 2. Section 22 1413 - Facility Storm Drainage Piping

1.3 QUALITY ASSURANCE

- A. The installation of Roof Drains shall be performed by an experienced Contractor using materials produced by reputable manufacturers. This installation shall be in strict accordance with the State and Local Codes, as well as with the published standards of the manufacturers of the materials.

1.4 SUBMITTALS

- A. Submit product data for all components to be used on the Project.
- B. Mark each proposed item in product data by circling or highlighting, and affix the corresponding Article and Paragraph designations from this Specification Section. Product data not so marked will be returned without review, for re-submittal complying with the above requirements.

1.6 DELIVERY, STORAGE AND HANDLING

- A. Cover and protect material in transit and at site. Material not properly protected and stored which is damaged or defaced during construction shall and will be rejected.
- B. Store materials in designated areas, out of the way of Owner's on-going operations.

PART 2 - PRODUCTS

2.1 ROOF DRAINS

- A. General.
 - 1. If required by roof construction, furnish extension/flange and drain extension. Refer to Drawings for roof construction details and location of roofing membrane.
 - 2. Furnish all drains with factory applied and performed coating; field or shop galvanize in the field as specified.

- B. New Roof Drains. Furnish a coated cast iron roof drain, equivalent to Zurn Z100 or approved equivalent, including:
 - 1. Flashing flange
 - 2. Combination membrane flashing ring/clamp with gravel stop
 - 3. Bottom outlet type
 - 4. Underdeck clamp
 - 5. Stainless steel, locking nuts to secure clamping ring to drain assembly.
 - 6. Extension ring sized to accommodate insulation thickness
 - 7. Coated cast iron, vandal proof mushroom dome.
- C. Field Applied Coating: Rustoleum Professional Flat Gray Cold Galvanizing Compound
- D. Overflow Discharge Nozzle: Wall mounted downspout nozzle, nickel bronze body and threaded outlet with wall anchor flange and countersunk holes. Provide MIFAB R1940 or equivalent.
 - 1. Anchors: stainless steel anchors, rated for use in existing wall substrate, sized to fit mounting holes provided at anchor flange.
 - 2. Sealant: Provide continuous bead of silicone sealant between anchor flange and wall substrate, Dow 790 or equivalent.
 - 3. Adapter for No-Hub connections: MIFAB MI-850 Series or equivalent.

PART 3 - EXECUTION

3.1 INSTALLATION

- A. Install components in accordance with Drawings, manufacturer's instructions and approved product data submittals.
- B. Set roof drains plumb, level, and rigid.
- C. Water test new and/or existing roof drains in accordance with the City of Belton Plumbing Code, inserting plug below level of new drain to existing pipe connection. Notify Engineer a minimum of two (2) days prior to test, and provide report of test results to Engineer for review.

END OF SECTION 22 1426

SECTION 23 0530 - MECHANICAL PROVISIONS

PART 1 - GENERAL

1.1 RELATED DOCUMENTS

- A. Drawings and general provisions of the Contract, including General and Supplementary Conditions and other Division 01 through Division 26 Specification Sections, apply to this Section.

1.2 SUMMARY

- A. This Section includes:
 - 1. Mechanical disconnection and re-connection.
 - 2. Moving and/or relocation of mechanical equipment.
 - 3. Modification of gas lines.
- B. Related Sections
 - 1. Section 26 0530 - Electrical Provisions

1.3 REFERENCES

- A. ANSI - American National Standards Institute
- B. ASME - American Society of Mech. Engineers.
- C. ASTM - American Society of Testing Materials.
- D. Uniform Plumbing Code.

1.4 WORK INCLUDED

- A. The work of this section consists of providing labor, materials, products, and all operations required for the complete operation and re-installation of all existing mechanical systems where shown and specified, in strict conformance with applicable drawings, specifications, terms and conditions of the contract and all applicable codes and ordinances governing the installation of the various mechanical systems. Contractor shall provide all equipment and materials necessary and usually furnished in connection with such work and systems whether or not specifically mentioned in the specifications or on the drawings. All work shall be coordinated with the work of other trades.
- B. Relocation, movement, disconnection and re-connection of mechanical equipment, gas lines, condensate lines, ductwork, etc.
- C. Pre-checking of all existing roof mounted HVAC, ventilation, and related equipment. Owner will verify that all mechanical equipment is in working order prior to Work starting. The Contractor shall pre-check each unit prior to the Work and provide a written report to the Architect prior to any disruption of the units.
- D. Demolition work: All demolition work for major equipment shall be performed by the prime contractor. All controls demolition work shall be performed by the controls contractor.
- E. Modification of existing gas lines with matching sizes, configuration, valves, support system, etc., as required. The Contractor shall test all gas lines in the presence of the Owner prior to the start of Work. Repair of any leaks or anomalies identified during this pre-check will be made by the

Owner or by change order issued to the Contractor.

- F. Testing of roof drains in the presence of the Owner or Owner's representative prior to the start of Work. Required repairs or opening of blockages identified during this process shall be performed by the Owner or by change order issued to the Contractor.
- G. All heating, air conditioning and ventilation Work shown in the Drawings and as indicated herein, or as may be implied by the Work.
- H. Lifting, moving, re-setting and/or modifications to existing equipment and curbs, including gas, condensation and electrical service lines, etc., whether shown on the Drawings or not.
- I. Installation of all sleeves and the cutting and patching of all holes necessary for the convenient and proper installation or disconnects and reconnections of the Work.
- J. Any Work installed without regard to the Work of other trades which must, in the opinion of the Architect, be relocated to permit the installation of other Work, shall be moved and reinstalled as a part of this Work without additional cost to the Owner.
- K. Existing conditions such as pavements, sidewalks, interior and exterior finishes and other Work shall be restored to their original or better condition where disturbed by Work of this Section.

1.4 QUALITY CONTROL

- A. The Mechanical and Plumbing Contractor(s) performing Work under this Section shall be a company qualified in the respective trade(s) with a minimum of five (5) years documented experience in working with the systems currently existing or herein specified. The company proposed to accomplish the Work shall show the successful completion of a minimum of five (5) similar projects of matching scope and monetary size accomplished by the company over the preceding three (3) year period.
- B. The Mechanical Contractor shall carry a State of Texas Class "B" license which shall be in effect at the time the project is bid and shall be maintained throughout the duration of the project. All requirements of the license and its administration shall be met in full.
- C. All Work shall be in strict conformance to the requirements of the latest accepted edition of the Uniform Mechanical and Plumbing Codes and any other codes which might be in force in the jurisdiction in which the Work is performed.
- D. The Plumbing and Mechanical Contractors shall be licensed by the State of Texas, provide proof of having such license prior to accessing the Work site, and properly display the appropriate license numbers where required in accordance with State law.
- E. Disconnection and reconnection of all HVAC controls must be performed by a qualified controls contractor. The controls contractor shall properly disconnect the controls before removal and reconnect the controls after the unit is set back in place.
 - 1. LAN cables must be disconnected as to not cause communications loss to other parts of the campus.
 - 2. Where LAN cables are found to be of insufficient length after raised rooftop unit curbs, cables shall be replaced in their entirety. Splicing cables in not allowed.

1.5 PRODUCT DELIVERY, STORAGE AND HANDLING

- A. Materials shall be delivered in bulk as necessary so as to provide continuous operations and no

delay in the progression of the Work. Schedule and coordinate with the Owner all necessary deliveries so as to cause the least inconvenience to the Owner's daily activities. All deliveries and unloading or loading activities shall be the responsibility of the Contractor; the Owner will not assume any responsibility for such activities.

- B. Store products in accordance with manufacturer's instructions, with seals and labels intact and legible. Store materials subject to weather and water damage in fully enclosed, watertight trailers. Maintain materials within temperature and humidity ranges required by manufacturer's instructions.
- C. For exterior storage of products, place on sloped supports above ground. Cover products subject to deterioration with impervious sheet covering. Provide ventilation and any required heating or cooling to avoid condensation.
- D. Store flammable products away from the building with all cans having sealed lids. Provide manufacturer's safety data sheets for all products delivered to the jobsite. Band together all loose pipe sections and stack no more than one pallet high. Store all loose fittings in marked boxes by size and type.
- E. Arrange storage to provide access for inspection. Periodically inspect to assure products are undamaged and are maintained under required conditions.
- F. Advise the Architect in writing a minimum of seventy-two (72) hours in advance of the shutdown of any equipment or service.

1.6 SUBMITTALS

- A. Submit product data and certificates under provisions of the applicable Division 01 Section. Provide manufacturers printed data on all materials provided including, but not limited to the following:
 - 1. Piping and fittings.
 - 2. Pipe insulation.
 - 3. Pipe sealers, adhesives and insulation.
 - 4. Ductwork.
 - 5. Duct insulation.
 - 6. Hangers and fasteners for piping and ductwork.
- B. Where significant relocation of mechanical equipment is anticipated submit shop drawings indicating the following at a minimum. Shop drawings shall be to scale and shall show all materials, fittings, new and/or existing equipment, and all incidentals to the Work required.
 - 1. Layout of ductwork and/or piping.
 - 2. Riser diagrams.
 - 3. Hanger diagrams indicating proposed attachment and locations.
 - 4. Ductwork jointing and all special sheet metal and insulating conditions.
 - 5. Mechanical curb extensions.
- C. Submit a schedule, indicating proposed time of disconnection and reconnection of existing condition, and proposed time each piece of equipment is proposed to be out of operation.
- D. Submit a plan of equipment removal and reinstallation indicating all procedures including method of evacuation and capture of fluorocarbons, controls maintenance, start-up after reinstallation, hoisting and lifting, and any other items specific to the equipment being affected.
- E. Building permits from the City of Austin, Texas are required for all mechanical, plumbing and

electrical Work. Copies shall be provided to the Architect per the applicable Division 01 Section.

1.7 CLOSEOUT PROCEDURES AND WARRANTY

- A. Prior to Substantial Completion submit operation and maintenance instructions in accordance with the provisions of the applicable Division 01 Section.
- B. Maintain record drawings of conditions throughout construction indicating deviations from the original Construction Documents and/or shop drawings. Prior to Substantial Completion submit two (2) record copies of red-marked prints of the original Drawings and Shop Drawings to the Owner indicating all changes.
- C. All Work provided under this Section shall be warranted for a period of not less than one-year, beginning on the Date of Substantial Completion for the entire project.

1.8 SCHEDULING

- A. Notify the Architect and Owner's representative a minimum of 72-hours in advance of the disconnection or re-location of any mechanical, plumbing or electrical line or appliance. Notification shall be weekdays only, and not include weekends.
- B. Disconnects and outages of existing mechanical equipment, ductwork, gas lines, etc., shall be scheduled at times convenience to the Owner. Times for shutdowns will be coordinated with the Contractor's and Owner's schedules beginning at the pre-roofing conference and as needed during the course of the Work.

PART 2 - PRODUCTS

2.1 MATERIAL AND PIPING SYSTEMS

- A. Piping Materials:
 - 1. Copper Tubing: ASTM B75-76.
 - 2. Wrought Copper Solder Fittings: ANSI B16.22.
 - 3. Steel Pipe: ASTM A53B.
 - 4. Malleable Iron Threaded Fittings: ANSI B16.3.
 - 5. PVC Piping: Schedule 40
 - 6. PVC Fittings: Schedule 40.
 - 7. Unions in Copper or Brass Lines: 125 pound all brass, screwed pattern, ground joint; Chase, Crane, Mueller, or an approved equal.
 - 8. Mechanical Couplings: Victaulic Style 77.
- B. Natural Gas Piping:
 - 1. Pipe 4 inches and smaller shall be either ASTM A53, Type F (continuous weld), Grade A, or B (Electric Resistance Weld) black carbon steel. Piping shall be a minimum Schedule 40, and of domestic (U.S.) manufacture.
 - 2. Piping shall be provided from the factory with end caps which shall remain in place until pipe is prepared for installation at the site. Materials found on the site without end caps shall be removed and replaced.
 - 3. Fittings for steel pipe shall be threaded for pipe 2 inches and smaller. For pipe larger than 2-inches fittings shall be butt welding type. Flanges shall be welding neck type. Fittings shall be long-radius type, and of domestic (U.S.) manufacture.
- C. Ductwork: New ductwork shall be minimum 24-gauge and heavier as required by existing

conditions. Ductwork shall be manufactured and sealed air and watertight. Ductwork construction shall strictly adhere to provisions of SMACNA.

- D. HVAC Unit Curb Extensions: Where unit curbs must be extended provide 18-gauge curb extensions with fully welded joints. Seal curb extensions to existing curb and to HVAC unit to prevent air leakage. Insulate to match existing curb.

PART 3 - EXECUTION

3.1 EXAMINATION

- A. Verify existing equipment conditions, dimensions, roof openings, wall penetrations and existing utility services are acceptable to receive Work of this Section.
- B. Verify conditions of existing utility piping, penetration, points and connections are acceptable to receive Work of this Section.
- C. Routing of piping as indicated in the Drawings is for general guidance. The Contractor shall coordinate his Work with the Architect and/or Owner and shall provide necessary deviations in routing as far as ten (10) feet from those shown or referred to in this Section to provide systems as specified or implied, without interference and pursuant to these requirements, at no additional cost to the Owner.

3.2 PREPARATION

- A. Protect interior finishes from damage prior to beginning demolition.
- B. Gain access to the underside of the roof deck as follows:
 - 1. Provide protective covering over all interior finishes in the areas of Work.
 - 2. Remove existing suspended ceiling panels and store for later re-installation. Replace all panels damaged with new material to match undamaged existing.
 - 3. Provide all required scaffolding and other supports required for safe access.
 - 4. Clean and remove all evidence of operations upon completion of Work each day.
 - 5. Re-install suspended ceiling panels upon completion of Work each day.
- C. Lay out drain piping routing on the underside of the deck, with locations marked for each support bracket. Advise the Architect in writing of obstructions which may require re-direction or alteration of the piping routing prior to proceeding with the Work.

3.3 PIPING INSTALLATION

- A. Install piping as indicated on the Drawings or where it currently exists and as is necessitated by the moving of associated mechanical units. The location of rooftop lines are shown schematically on the Drawings. The Contractor shall be responsible for variances of up to 5'-0" from the locations shown on the Drawings, and for any and all additional bends, fittings and supports that may be required for a complete project. The Contractor shall be responsible for determining the extent of Work required above and below the deck for any piping relocation or modifications.
- B. All systems shall be straight and true and properly graded for correct flow of contained materials, and to provide drainage. Cut pipes accurately to measurements established at the building and Work into place without forcing or springing.
- C. Make all changes in pipe sizes with reducing fittings. Use no long screws or bushings.

3.4 HOISTING

The Contractor shall be responsible for hoisting all materials and equipment to be furnished, modified, relocated or installed under this Section. All hoisting shall be compliant with all OSHA, state and federal codes and regulations.

3.5 GAS PIPING

A. General:

1. Precautions shall be taken at all times to prevent the entry of dirt or debris into the gas lines or other parts of the system. Remove end caps only immediately prior to installation of the piping on the roof. Clean piping by purging with clean compressed air. Store pipe on hard surfaces, or in trailers at the site until ready for use. Prior to installation each pipe, fitting and valve shall be visually inspected and cleaned.
2. Cut pipe accurately to measurements established at the site and Work into place without springing or forcing. Remove burrs by reaming and install so as to permit free expansion and contraction without damage to joints or supports. Fittings are required for all changes in direction. Install piping with sufficient pitch to ensure adequate drainage and venting.
3. Piping connections to equipment shall be provided with unions or flanges. Open ends of pipelines or equipment shall be properly capped or plugged during installation to keep dirt and other foreign material out of the system. Run cleaning swab through all pipe immediately prior to installation.

B. Joints:

1. Screw Joints: Made with threads properly cut conforming to NFP A54 and ASME B31.2 requirements. Joints shall be made tight with a thread joint compound resistant to and compatible with the natural gas being supplied.
2. Welded Joints: Fusion-welded in accordance with ASME B31.2 - Fuel Gas Piping, unless otherwise required.
3. Changes in Direction of Piping: Made with factory fabricated screw or weld fittings only. Mitering, or notching pipe to form elbows and tees or other similar construction will not be permitted. Branch connections shall be made with factory fabricated screw or weld tees.
4. Field and Shop Bevels: Provide for butt joints of straight pipe runs and execute in accordance with the recognized standards and shall be done by mechanical means or flame cutting. Where beveling is done by flame cutting, surfaces shall be cleaned of scale and oxidation prior to welding.
5. Component Parts to be Welded: Align before welding so that no strain is placed on the weld when finally positioned. Height shall be so aligned. Elbows and branches shall be true. Alignment shall be preserved during the welding operation.
6. Flanges and Unions: Faced true, provided with appropriate gaskets, and made square and tight. Union or flange joints shall be provided in each line immediately preceding the connection to each piece of equipment requiring maintenance such as heat exchangers, air conditioning units and other similar items.
7. Temperature: Where the temperature of the component parts being welded reaches 32°F or lower, the material shall be heated to approximately 100°F for a distance of 3 feet on each side of the weld before welding, and the weld shall be finished before the material cools to 32°F.
8. Electrodes: Stored in a dry heated area and shall be kept free of moisture or dampness during fabrication operations. Electrodes that have lost part of their coating shall be discarded.
9. Movement Control: Provide approved anchors and suitable swing joints to control the movement of all piping subject to expansion, contraction, vibration, and flow forces.

- C. Welder's Qualifications: Provide written certification that every welder employed on the job has passed qualification tests for the piping systems to be installed as prescribed by the National Certified Pipe Welding Bureau or other reputable testing laboratory using ASME or American Welding Society procedures. Any defect found as a result of Owner directed testing shall be cause for dismissal of the welder from the project. All costs of such tests shall be borne by the Owner unless welder's test coupon or coupons fails such test, and then costs shall be paid by the Contractor.
- D. Unions and Flanges: Provide unions or flanges as applicable in piping systems at points of connection to items of equipment and elsewhere as indicated or required to permit proper connections. Locate unions or flanges so that equipment may be removed without disturbing piping system.
- E. Expansion of Piping: Provide approved anchors and suitable swing joints to control the movement of all piping subject expansion, contraction, vibration, and flow forces.
- F. Testing:
 - 1. Following completion of the gas system on each side of the building the Contractor shall, at his own expense, test the gas piping installation per these Specifications and applicable local codes. All leaks shall be immediately remedied and the testing reapplied. Testing shall be repeated until all leaks are repaired.
 - 2. Pressurize gas piping system from the nearest available isolation valve which was not a part of any portion of the natural gas piping system revisions and the various existing natural gas fired equipment to 15 inches of mercury with compressed air. Valve-off the system from the air source and observe for one (1) hour. If pressure loss occurs, determine the location of the leak(s) with soap film, repair leak and re-test.
 - 3. All gas lines shall be tested by the City of Austin upon completion of that segment of the Work. Coordination with the Owner's maintenance personnel shall be made in advance to allow them to be present to observe the tests.

3.6 ACOUSTICS AND VIBRATION

- A. All items, new or reinstalled under this Section, which are a source of noise and/or mechanical vibration generation, shall be installed with proper attenuation provision, including absorbers, isolators or mufflers as required to prevent objectionable noises and vibrations within the building.
- B. Where absorbers or isolators are found to be deteriorated or damaged prior to equipment relocation, such conditions shall be called to the attention of the Architect and Work shall not proceed until such time as the issue is addressed. Where these devices are determined to be in good condition they shall be reinstalled in working order.

3.7 REMOVED MECHANICAL EQUIPMENT

- A. All mechanical equipment, wiring, copper components and controls determined to not be reused remain the property of the Owner and shall be delivered to its designated storage location on the day of removal. Any materials lost in transit shall have its value restored to the Owner. Any equipment designated to be removed and not returned to the Owner and any conduit or steel piping not reused by the Contractor shall be disposed of as part of the Contract.

3.8 TESTING OF RELOCATED MECHANICAL EQUIPMENT AND LINES

- A. All HVAC and ventilation equipment which is moved or disturbed shall be tested prior to its removal and again following re-installation.

1. Testing shall be performed prior to the equipment being disturbed. A written report containing all procedures and deficiencies identified shall be provided to the Architect prior to disturbing or moving the equipment.
 2. The Contractor shall be solely responsible for the proper operation of all roof mounted equipment following completion of the Work, with the exception of items noted in the initial inspection report.
- B. Roof Drain Testing and Procedures:
1. Prior to start of Work all roof drains shall be tested by the Contractor in the presence of the Owner, Owner's representative or Architect. If testing shows leakage of a drain line or blockage the Contractor will immediately provide a letter to the Architect documenting the condition. Once Work begins responsibility for the roof drains regarding any leakage and blockages shall rest with the Contractor.
 2. The Contractor shall be responsible for the watertight integrity of all roof drains to drain lines.
 3. All roof drains shall be tested for a period of one hour following completion of the Work and prior to Substantial Completion. Final testing will occur only in the presence of the Owner's designated representative. It is the sole responsibility of the Contractor's to schedule and conduct this testing.
 4. Replace all missing roof drain strainers and drain bolts at no additional cost to the Owner, whether they were noted on the Drawings or not.
 5. After all components of the drainage and pipe system are installed all drains shall be water tested. Flood each assembly with water in the presence of the Architect, or his designated representative, for a period of not less than one (1) hour.
- C. Pressure Testing:
1. The refrigerant piping shall be tested before any covering is applied, using carbon dioxide or dry nitrogen, and Freon under pressure as hereinafter specified. The high side shall be tested at 300 psig for R-12 and 450 psig for R-22. The low side shall be tested at 150 psig.
 2. Tests shall be accomplished in accordance with procedures recommended by the equipment manufacturer. The Owner shall be notified 24-hours in advance of any testing.
 3. With the test pressure in the system, all joints shall be sharply tapped with a rubber or rawhide mallet sufficiently hard to break loose any defective joints. Every joint shall then be swabbed with a soap solution. After testing, the solution shall be wiped off each joint.
 4. If any leaks are found, the pressure shall be relieved from the system; the leaking joint shall be disassembled, thoroughly cleaned, and remade as a new joint. Tests shall then be conducted again in the same order as listed above.
 5. After the system is found to be leak-free by the aforementioned process, Freon shall be introduced with an inert gas at the same pressures, hereinbefore specified, at a rate of 0.5 lb. per ton of refrigeration. All joints shall then be carefully tested with a halide torch or electronic leak detector and any leaks found shall be repaired as specified above. After the system is found to be tight, it shall be allowed to stand under test pressure, disconnected from the pressure source, for a period of 24-hours. If the system loses pressure, other than that caused by temperature changes, then further tests for leaks shall be made.
- D. System Evacuation:
1. After completion of the above pressure tests, the system shall be evacuated using an approved auxiliary vacuum pump.
 2. Connections for evacuation shall be in accordance with the specific equipment manufacturer's recommendations.
 3. A vacuum dehydration indicator shall be used. Dial-type gauges are not acceptable.
 4. The vacuum pump shall be operated until a vacuum in excess of 150 microns is obtained and has been maintained for a period of at least four hours. The vacuum shall then be broken with Freon and the system shall again be evacuated as specified.

5. Evacuation shall not be undertaken when the ambient temperature around the equipment is lower than 70 degrees F.
- E. Charging of the systems shall be given through the charging valve in the high side passing all liquid refrigerants through a charging dehydrator. All charging lines and gauges shall be purged of air prior to connection with the system. The refrigerant shall be unused and shall be delivered in clean drums. After the system is fully charged, it shall be started and while in operation tested again for leaks with a halide torch or electronic leak detector. After successful completion of all tests, the piping will be insulated with new materials and the system placed in full operation.
- F. The Contractor shall keep accurate records of all testing and charging of the system and deliver the records to the Owner upon completion of the charging of each unit.

END OF SECTION 23 0530

SECTION 26 0530 - ELECTRICAL PROVISIONS

PART 1 - GENERAL

1.1 RELATED DOCUMENTS

- A. Drawings and general provisions of the Contract, including General and Supplementary Conditions and other Division 01 Specification Sections, apply to this Section.

1.2 SUMMARY

- A. This Section includes:
 - 1. Electrical disconnection and re-connection.
- B. Related Sections:
 - 1. Section 23 0530 - Mechanical Provisions

1.3 WORK INCLUDED

- A. All labor, materials, equipment and related items required to disconnect and re-connect all equipment, electrical relocations as required to accommodate proper roof flashings, and to complete the Work within the intent of the Drawings and Specifications, whether or not specifically mentioned or shown therein. For this reason, the Contractor shall visit the site before submitting his bid and familiarize himself with the areas in which Work is to be done.
- B. Electrical Work necessary for this project includes but is not limited to the resetting of conduit for building and HVAC units, removal of unused conduits, the disconnecting and reconnecting of electrical supply to HVAC and other mechanical units scheduled to receive new or modified curbs, etc., all in accordance and necessary to achieve proper flashing heights and details.
- C. Modifications to the existing communications cables (fiber optics) will be accomplished by the Owner. No disruption may occur in these lines without minimum 72-hour written notice to the Architect and Owner and granting of approval.
- D. Set all sleeves and cut and patch all miscellaneous holes necessary for the convenient and proper installation of the Work as applicable. Required holes through existing masonry construction with an area of less than 35 square inches shall be considered miscellaneous holes.
- E. Any Work installed without regard to the Work of other crafts which must, in the opinion of the Architect, be moved to permit the installation of other Work, shall be moved and replaced as part of this Work without extra charge.
- F. Removed conduits shall have all associated wire and cables taken back to associated circuit breaker, fuse box or other such junction so as to allow for complete removal with no exceptions taken with regards to safety or code requirements.
- G. All Work shall be accomplished within the scheduled shutdown times arranged in accordance with provisions in Section 23 0530, Article 1.8.
- H. Follow and be responsible for all necessary contract closeouts, hoisting, caulking and sealants, hangers and related items pertaining to this contract.

1.4 REFERENCES

- A. ANSI/NFPA 70 – National Electrical Code.

1.5 SUBMITTALS

- A. Submit under provisions of Section 01 3300.
- B. Submit shop drawings and product data grouped to include complete submittals of related systems, products, and accessories in a single submittal.
- C. Mark dimensions and values in units to match those specified.
- D. Proposed Products List: Include Products specified in this Section and all Products required for execution of Work:
- E. Schedule: List each area of Work and all systems or equipment affected. Indicate proposed time of disconnection, re-connection, and durations for shutdowns.
- F. Closeout Submittals: Submit under provisions of Section 01 7800.
- G. Project Record Documents: Accurately record exact location of roof penetrations and any items installed but not visible after installation of roofing system or other Products.

1.6 QUALIFICATIONS

- A. Installer: Company specializing in installing the Work of this Division with a minimum of five (5) years documented experience working with the systems and Products in place and proposed or required. Licensed by jurisdiction having authority to perform the required Work.

PART 2 - PRODUCTS

2.1 MATERIALS

- A. Where mechanical items must be disconnected and re-connected as necessary by the re-roofing of specified areas at these facilities, all wires, conduits, panels, motor starters, raceways, switches, stations, etc., shall be replaced or renewed to match existing if damaged, cut or needing extension, etc. All materials shall meet the minimum standards of the National Electrical Code; latest edition adopted by the City of Austin, Texas.
- B. Prior to installation, coordinate all necessary Work with associated trades and Owner.

PART 3 - EXECUTION

3.1 PERFORMANCE

Work shall be performed by a qualified electrical contractor, licensed to do Work in the City of Austin, Travis County and the State of Texas. All workmanship shall be in compliance with all code requirements and shall be inspected as required by all governing authorities. All Work shall meet the minimum standards of the latest edition of the National Electrical Code.

3.2 ELECTRICAL WIRING AND SYSTEMS REPAIRS

- A. Verify need and extent of all repairs with Owner's Representative. Coordinate shut-down and start-up requirements for each system and each occurrence.
- B. Remove conduit and associated materials from point of damaged to nearest pull box or other connection point in both directions, unless instructed otherwise by Owner's Representative.
- C. Replace existing wiring with new conduit and wiring of same diameter and gage as original.
- D. Use screwed or welded connections to match existing conditions.
- E. After repairs are completed, but prior to covering or concealing repaired elements, test repairs at full load or power, under observation by Owner's Representative.
- F. Seal all connections watertight, including those between new and existing materials.

3.3 SCHEDULING

- A. All Work necessary shall be in compliance with Owner's requests for proper scheduling so that the least amount of interference with daily production and school duties is required. Work requiring the disconnection or re-connection of any electrical or communication line(s) must be coordinated through the Architect with a minimum of 72-hours written notice.
- B. All electrical disconnects shall be accomplished during periods when school will not be disrupted by power outages.

END OF SECTION 26 0530

AUSTIN INDEPENDENT SCHOOL DISTRICT



AISD PROJECT NO. 18-0023-HOUST ROOF REPLACEMENT HOUSTON ELEMENTARY SCHOOL 5409 PONCIANA DR. AUSTIN, TX 78744

LIST OF MEMBERS OF BOARD OF TRUSTEES

GERONIMO M. RODRIGUEZ, JR., VICE PRESIDENT, DISTRICT 6
 JULIE COWAN, SECRETARY, DISTRICT 4
 EDMUND T. GORDON, DISTRICT 1
 JAYME MATHIAS, DISTRICT 2
 ANN TEICH, DISTRICT 3
 AMBER ELEN, DISTRICT 5
 YASMIN WAGNER, DISTRICT 7
 CINDY ANDERSON, AT-LARGE POSITION 8
 AT-LARGE POSITION 9 - VACANT

PAUL CRU, P.E., SUPERINTENDENT
 BOB CERVI, EXECUTIVE DIRECTOR OF CONSTRUCTION MANAGEMENT AND FACILITIES
 JACK PEARCE, DIRECTOR OF PROJECT MANAGEMENT
 NICOLE CONLEY JOHNSON, CHIEF FINANCIAL OFFICER

SITE LOCATOR LEGEND

SYMBOL	DESCRIPTION
	HOUSTON ELEMENTARY SCHOOL 5409 PONCIANA DR. AUSTIN, TX 78744

SHEET INDEX

SHT. NO.	DESCRIPTION
R0	COVER SHEET
R1	KEY PLAN, WIND ZONE PLAN, PARTIAL ROOF PLANS, ROOFING SCHEDULES
R2	PARTIAL ROOF PLAN
R3	PARTIAL ROOF PLAN
R4	ROOFING DETAIL
R5	ROOFING DETAIL
R6	ROOFING DETAIL
R7	ROOFING DETAIL

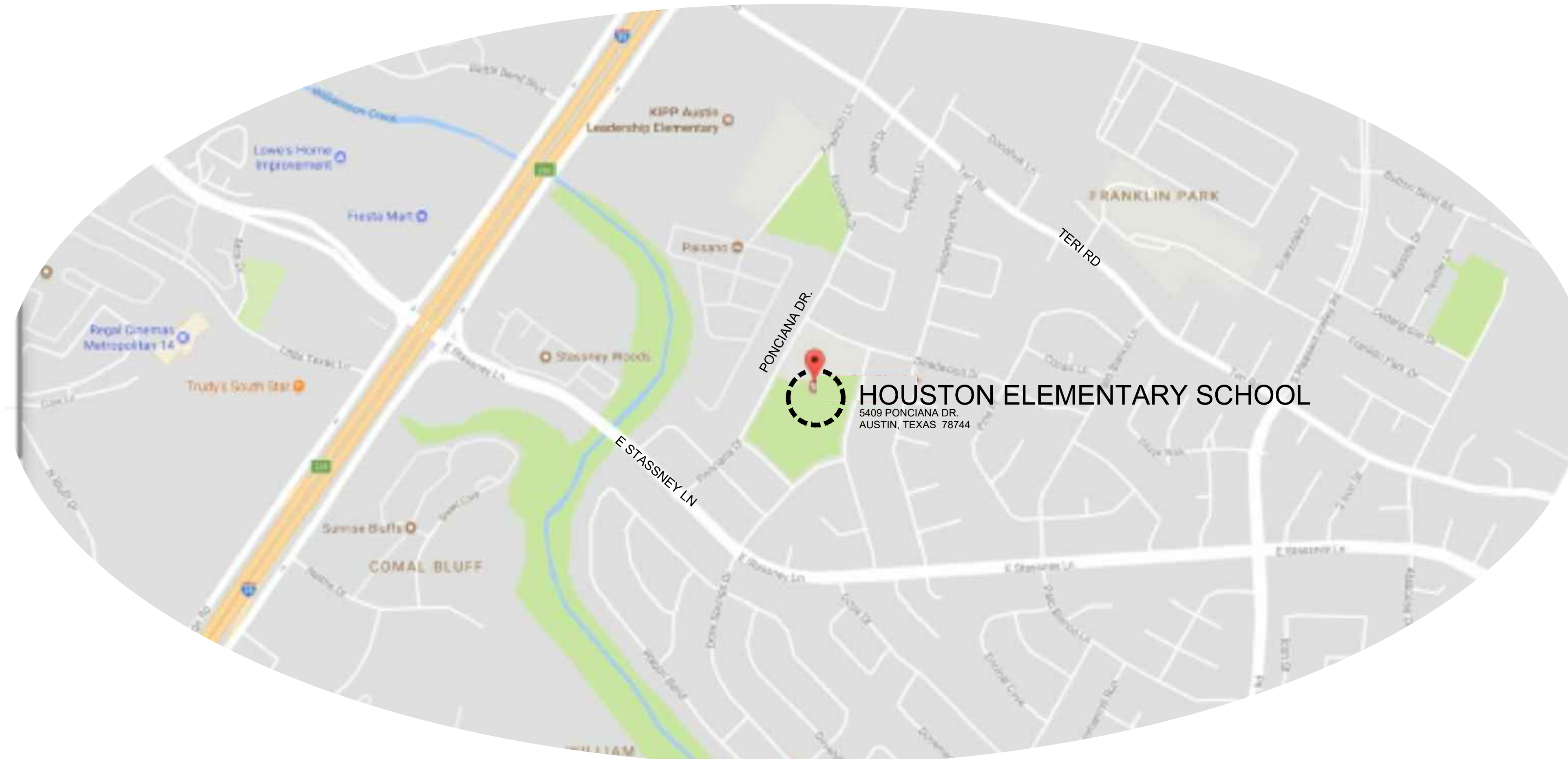

SITE MAP - HOUSTON ELEMENTARY SCHOOL
NOT TO SCALE
PLAN NORTH

h c
g
hollon
+cannon
group, inc.
11800 Highland Oaks Trl | Austin, TX 78750
P: 512.300.0432
www.holloncannon.com

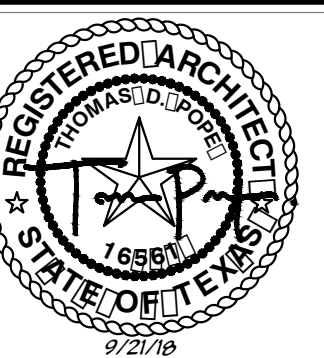

COVER SHEET
 DRAWN BY: TDP
 CHECKED BY: CANNON J
 DATE: 09/21/18
 SHEET:

SET NO.

R0

2. FIELD MEASUREMENTS ARE REQUIRED FOR BIDDING PURPOSES.
3. REMOVE BITUMEN DRIFTAGE FROM MASONRY WALL SURFACES BELOW AWARDED ROOFING SECTIONS.
4. CONTRACTOR IS RESPONSIBLE FOR VERIFICATION OF EXISTING ROOFING SYSTEM DRAINAGE:
- CRICKETS / BATTLES SHALL BE TWICE THE ADJACENT ROOF SLOPE.
 - PROVIDE TAPERED CRICKETS ON HIGH SIDE OF CURBED PENETRATIONS AS RESP'D TO DRECT DRAINAGE AROUND PENETRATION.
 - CONTRACTOR SHALL FIELD VERIFY EXACT CRICKET SIZE AND PROFILE IN THE FIELD TO ENSURE POSITIVE DRAINAGE AROUND CURBED PENETRATIONS.
 - PROVIDE DOWNPOUTS WHERE SHOWN ON PLAN, AND AT LOCATIONS TO MATCH EXISTING WHETHER SHOWN ON THE PLAN OR NOT.
- ROOF TOP EQUIPMENT / PENETRATIONS:
- CONTRACTOR SHALL VERIFY OPERATIONAL STATUS OF ROOF TOP EQUIPMENT W/ OWNER PRIOR TO COMMENCING WITH THE WORK.
 - ABANDONED EQUIPMENT AND CURBS SHALL BE REMOVED FROM THE BUILDING, AND DEPOSED OF. REPAIR DECKING AT ABANDONED PENETRATIONS (NOT EXCLUDED ON THE DRAWINGS FOR REMOVAL) PER UNIT PRICING, DETAILS AND SPECIFICATIONS.
 - EXISTING GAS, CONDENSATE, ELECTRICAL, HYDRONIC PIPING, ETC. SHALL BE RECONNECTED, RAISED AND RECONNECTED AS RESP'D TO ACCOMMODATE NEW ROOF SYSTEM THICKNESS AND MEMBRANE FLASHING HEIGHT REQUIREMENTS.
 - EXISTING ROOF TOP EQUIPMENT SHALL BE DISCONNECTED, RAISED AND RECONNECTED AS RESP'D TO PROVIDE MEMBRANE BASE FLASHING HEIGHTS SPECIFIED.
 - EXISTING FLUCT WORK SHALL BE DISCONNECTED, RAISED AND RECONNECTED AS RESP'D TO ACCOMMODATE NEW ROOF SYSTEM THICKNESS AND MEMBRANE FLASHING HEIGHT REQUIREMENTS.
 - LOCATION AND ROUTING OF PIPING / CONDUIT SHOWN ON ROOF PLAN IS SCHEMATIC. CONTRACTOR TO FIELD VERIFY LOCATION AND ROUTING EQUIPMENT / PIPING SUPPORTS:
- APPROPRIATE PIPE SUPPORTS ARE DETERMINED BY OUTSIDE DIAMETER OF PIPING / CONDUIT. RE SPECIFICATION SECTION 07 7200 FOR DESCRIPTIONS OF DESIGNATED ROOF TOP PIPE SUPPORTS:
 - TYPE "A" - FIXED HEIGHT PIPE SUPPORT RE. DETAIL 1/RS
 - TYPE "A" - ADJUSTABLE HEIGHT PIPE SUPPORT RE. DETAIL 2/RS
 - TYPE "B" - ADJUSTABLE HEIGHT PIPE SUPPORT RE. DETAIL 3/RS
 - TYPE "C" - HANGING PIPE SUPPORT RE. DETAIL 4/RS
 - TYPE "D" - CURB MOUNTED PIPE SUPPORT RE. DETAIL 5/RS
 - PIPING OR CONDUIT INSTALLATION SHALL PROVIDE A MINIMUM CLEARANCE OF 12" ABOVE FINISHED ROOF SURFACE FOR SUPPORT TYPES "A", "B", "C".
 - ELEVATION OF PIPING / CONDUIT ABOVE FINISHED ROOF SURFACE SHALL BE COORDINATED WITH FLASHING HEIGHT OF ASSOCIATED EQUIPMENT SUPPORT CURB FOR SUPPORT TYPE "D".
- TREATED WOOD BLOCKING
- PROVIDE ISOLATION TAPE BETWEEN TREATED WOOD BLOCKING AND METAL COMPONENTS, WHETHER SHOWN IN DRAWINGS OR NOT.
- PAINTING:
- SCRAPE, PRIME AND PAINT GAS LINES
 - SCRAPE, PRIME AND PAINT STEEL LADDERS
 - SCRAPE, PRIME AND PAINT STEEL FRAMES
- TRAFFIC PROTECTION:
- PROVIDE TRAFFIC PROTECTION PADS AT ROOF ACCESS POINTS AND ON ALL SIDES OF ROOF TOP UNITS.

○			2/R4
○	PB	PENETRATION SEAL	1/R4
○	V	FLANGED VENT	3/R4
○	HD	HOT STACK	6/R4
○	RP	PRIMARY ROOF DRAIN	4/R6
○	RP	SUPPLEMENTAL DRAIN	3/R6
□	HP	HOOPER PENETRATION	7/R4
⊗	EF	EXHAUST FAN	3/R4
⊗	VT	CURBED VENT	3/R4
⊗	EP	SPLASH PAN	9/R4
⊗	AB	ABAND. EQUIPMENT	13/R4
⊗	EPB	ELECT. DISCONNECT	8/R4
□	CU	CONDENSING UNIT	5/R4
▨	RTU	ROOF TOP UNIT	
—	C	CONDENSATE LINE	
—	E	ELECTRICAL LINE	SECTION 07 7200
—	G	GAS LINE	
—		TAPERED INSULATION	
—		DRAINAGE SLOPE	
—		NOT IN CONTRACT	
—		ROOF SECTION CONTINUED ON SEPARATE PAGE	
—		INDICATED LOCATION OF 1/2" / FT. TAPERED INSULATION	
—		TAPERED CRICKET	
—		TRAFFIC PAD	

- METAL DECK
- 2-3/4" FIBERGLASS INSULATION
- 4-PLY BUILT-UP ROOFING MEMBRANE
- ASPHALT FLOOD COAT AND GRAVEL
- 3/4" PERLITE RECOVER BOARD
- 2-PLY MODIFIED BITUMEN ROOFING MEMBRANE
- ROOF SECTIONS: A03 □ □ A10
- METAL DECK
- 2-3/4" POLYISOCYANURATE INSULATION
- 3/4" PERLITE INSULATION
- 2-PLY MODIFIED BITUMEN ROOFING MEMBRANE

- HOUSTON ELEMENTARY SCHOOL
NEW ROOF ASSEMBLY SCHEDULE**
- ROOF SYSTEM NO. 1: □ □ □ A10
DETAIL 2/R1:
- REMOVE EXISTING ROOFING SYSTEM TO METAL DECKING
- FLAT, 1/8" PH. ± 1/2" TH. TAPERED POLYISOCYANURATE INSULATION W/ 4.5" STARTING THICKNESS - MECHANICALLY FASTENED (SEE ROOF PLAN FOR LOCATION OF TAPERED INSULATION)
- 1/2" GYPSUM COVER BOARD - SET IN ADHESIVE
- 888 MODIFIED BITUMEN BASE FLY - TORCH APPLIED
- 888 MODIFIED BITUMEN CAP SHEET - TORCH APPLIED

- KEYED NOTES TO CONTRACTOR**
- PRIMARY ROOF DRAIN PER DETAIL 4/R6
 - SUPPLEMENTAL ROOF DRAIN PER DETAIL 3/R6
 - DOWNPOUT PER DETAIL 1/R6 - 888. CONDUIT DOWNPOUT DOWN TO ROOF BELOW PROVIDE SPLASH PAN PER DETAIL 9/R4
 - DOWNPOUT PER DETAIL 1/R6. CONDUIT DOWNPOUT DOWN TO GRADE PROVIDE DOWNPOUT BOOT PER DETAIL 2/R6
 - LADDER PER DETAIL 3/R7. PROVIDE 3'-0"x6'-0" TRAFFIC PROTECTION PAD AT BOTH TOP AND BOTTOM OF LADDER
 - RELOCATE UNIT AS SHOWN. MODIFY CONDUIT AND UNIT ACCESSORIES AS RESP'D. PROVIDE EQUIPMENT SUPPORTS PER DETAIL 5/R4. SUPPORTS SHALL BE SPAN A MINIMUM OF TWO JOISTS.
 - PROVIDE NEW ALUMINUM LADDER WITH MOUNTING END @ PLANE OF NEW WALL PANELS. EXTEND FLUETING AND ACCESSORIES AS RESP'D.
 - REMOVE AND DEPOSE OF ABANDONED EQUIPMENT. PROVIDE DECK REPAIR PER DETAIL 13/R4
 - OVERFLOW SCUPPER PER DETAIL 5/R7
 - EXTEND EXPANSION JOINT CURBS TO BUILDING PERIMETER. ENSURE EXPANSION JOINT IS CONTINUOUS TO ROOF EDGE. PROVIDE EJ TERMINATION PER DETAIL 6/R5 OR 7/R5

ROOF SYSTEM WIND UP-LIFT PRESSURES AND PERIMETER DIAGRAM

<p>MEAN ROOF HEIGHT ≈ 60 Ft.</p> <p>ZONE 1 = FIELD ZONE 2 = PERIMETER ZONE 3 = CORNER</p> <p>SAMPLE PLAN VIEW OF ROOF</p> <p>a = 10% OF LEAST HORIZONTAL DIMENSION OF BUILDING OR 0.4 ft, WHICHEVER IS SMALLER, BUT NOT LESS THAN EITHER 4% OF LEAST HORIZONTAL DIMENSION OR 3 Ft.</p>	<p>MEAN ROOF HEIGHT ≈ 60 Ft.</p> <p>ZONE 1 = FIELD ZONE 2 = PERIMETER ZONE 3 = CORNER</p> <p>SAMPLE PLAN VIEW OF ROOF</p> <p>a = 10% OF LEAST HORIZONTAL DIMENSION OF BUILDING, BUT NOT LESS THAN 3 Ft.</p>	<p>DESIGN ASSUMPTIONS (CONTRACTOR SHALL VERIFY ASSUMPTIONS W/ MANUFACTURER)</p> <p>BASIC WIND SPEED = 120 MPH</p> <p>EXPOSURE CATEGORY = B</p> <p>CLASSIFICATION OF ENCLOSURE = PARTIALLY ENCLOSED</p> <p>RISK CATEGORY = III</p> <p>TOPOGRAPHIC FACTOR = 1</p> <p>WIND UP-LIFT PRESSURES (P_{WF}) (CONTRACTOR SHALL VERIFY PRESSURES W/ MANUFACTURER)</p> <table border="1"> <thead> <tr> <th>BUILDING HEIGHT</th> <th>FIELD</th> <th>PERIMETER</th> <th>CORNER</th> </tr> </thead> <tbody> <tr> <td>0 to 30'-0"</td> <td>-34.0</td> <td>-51.6</td> <td>-73.5</td> </tr> <tr> <td>30'-0" to 40'-0"</td> <td>-36.9</td> <td>-56.0</td> <td>-79.8</td> </tr> <tr> <td>40'-0" to 50'-0"</td> <td>-39.4</td> <td>-59.7</td> <td>-85.1</td> </tr> </tbody> </table> <p>DESIGN UP-LIFT PRESSURE (P_{WF}) INSTALLED WIND UP-LIFT RESISTANCE VALUES SHALL BE TWO (2) TIMES THE SPECIFIED WIND UP-LIFT PRESSURES</p>	BUILDING HEIGHT	FIELD	PERIMETER	CORNER	0 to 30'-0"	-34.0	-51.6	-73.5	30'-0" to 40'-0"	-36.9	-56.0	-79.8	40'-0" to 50'-0"	-39.4	-59.7	-85.1
BUILDING HEIGHT	FIELD	PERIMETER	CORNER															
0 to 30'-0"	-34.0	-51.6	-73.5															
30'-0" to 40'-0"	-36.9	-56.0	-79.8															
40'-0" to 50'-0"	-39.4	-59.7	-85.1															

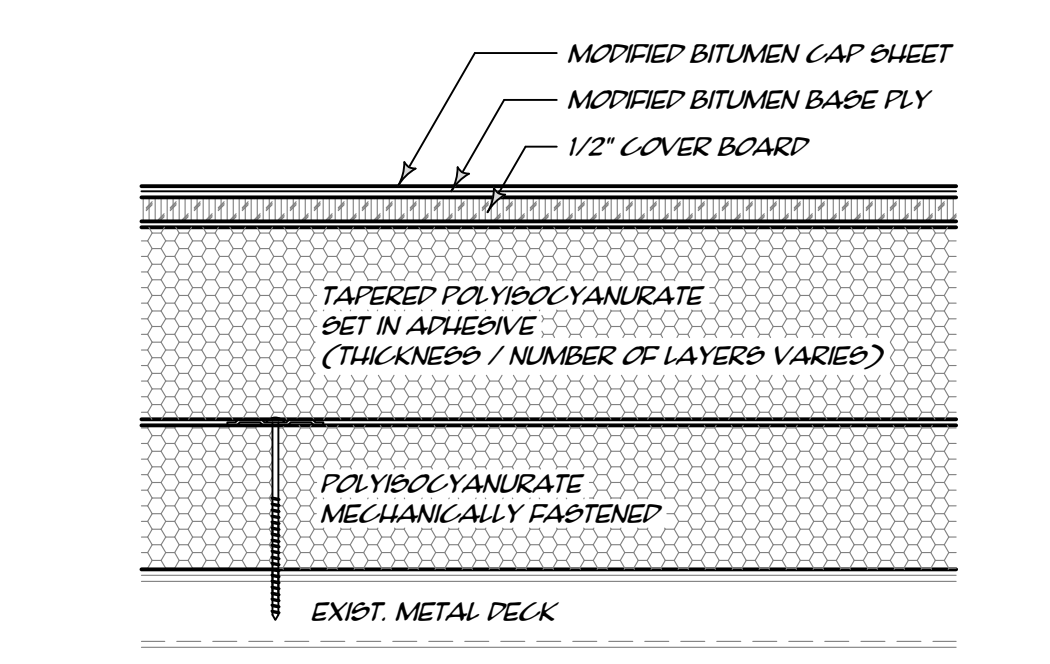

**SECTION THRU ROOF ASSEMBLY
ROOF SYSTEM NO. 2**

2
R1 3" = 1'-0"

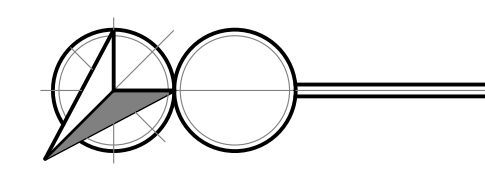
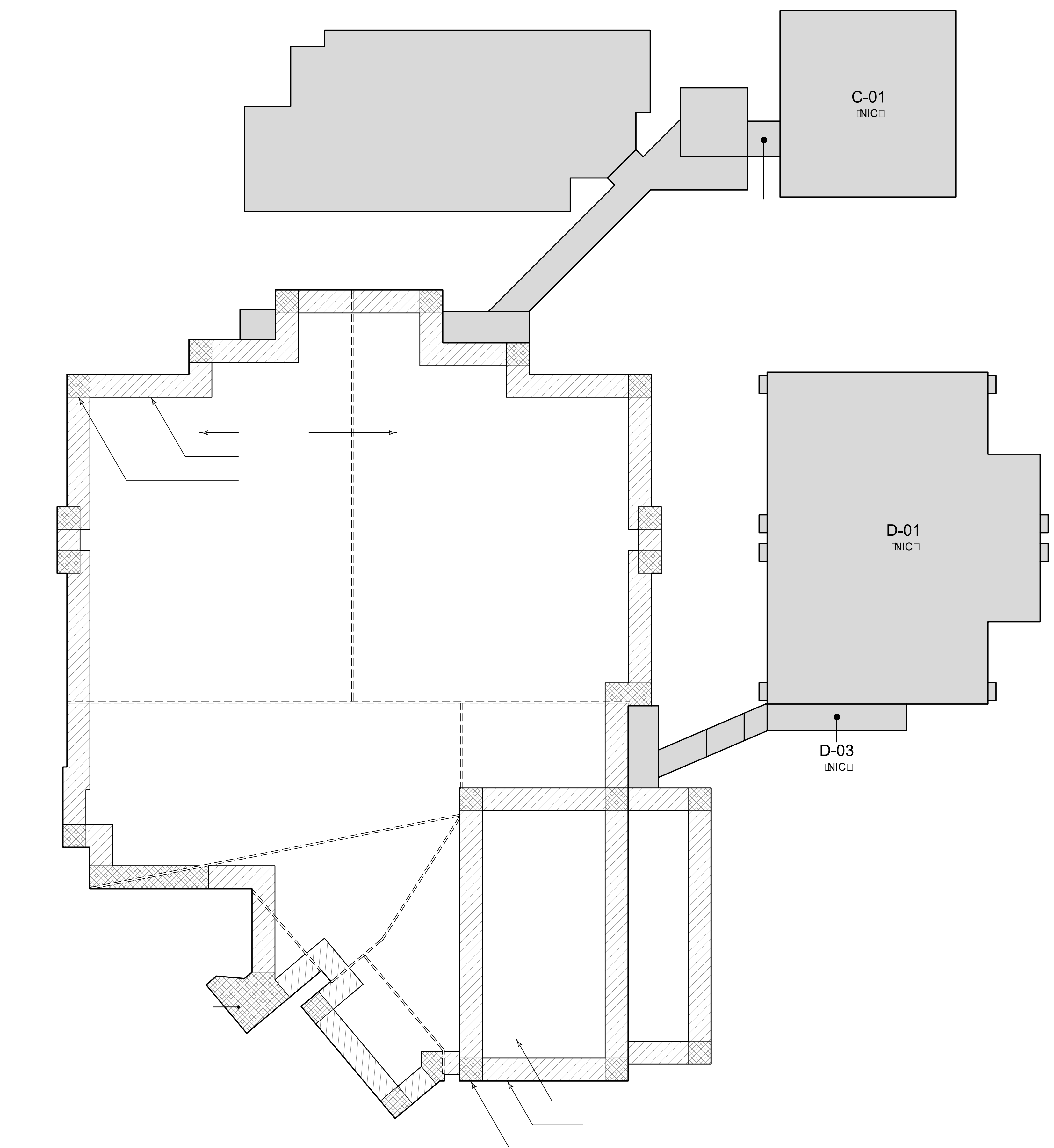

REVISION SCHEDULE:

1.	
2.	
3.	
4.	
5.	
6.	
7.	

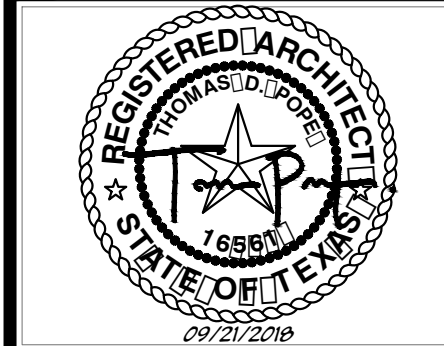

WIND ONE PLAN SCHEDULES, NOTES AND DETAILS

DRAWN BY:
MWH

CHECKED BY:
JC

DATE:
09/21/2018

SHEET:

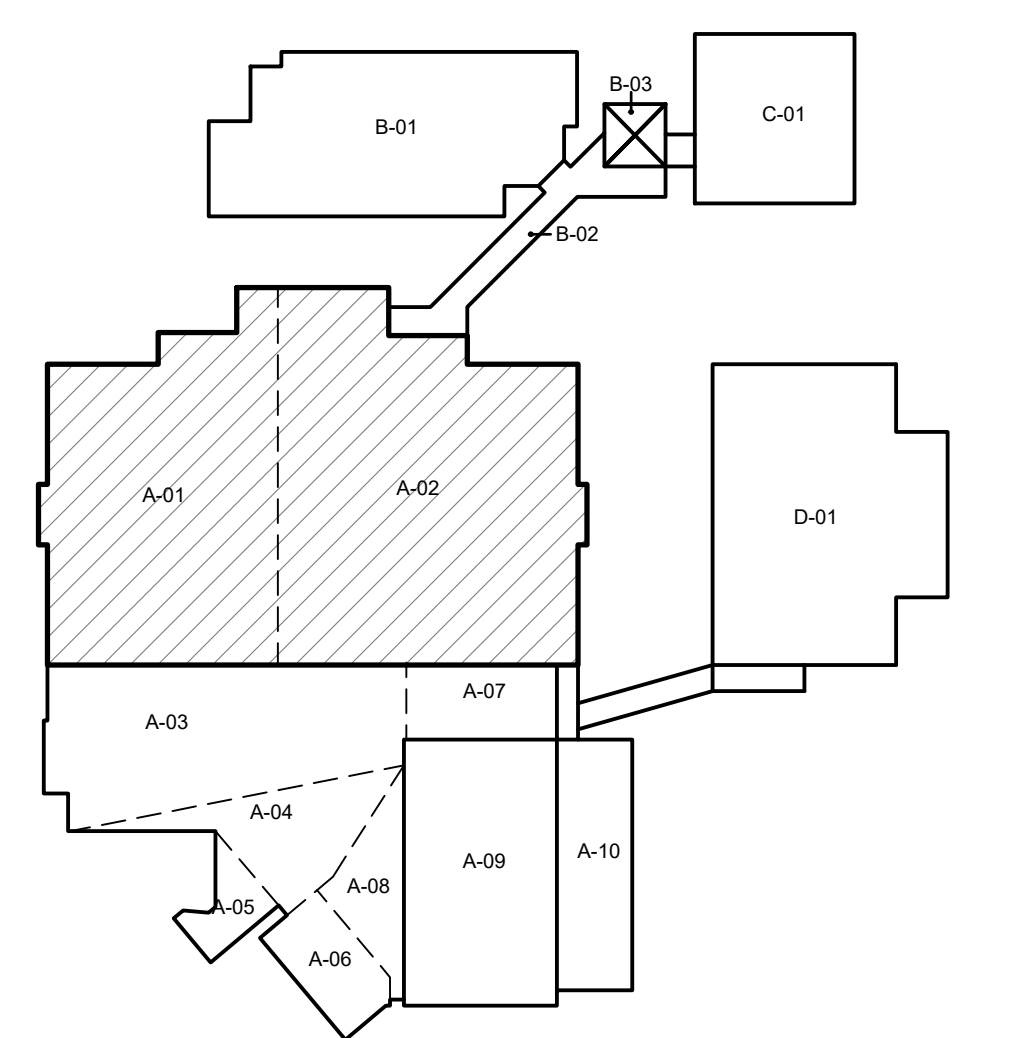
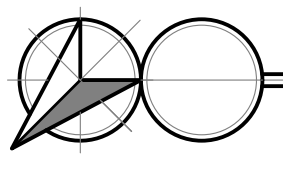
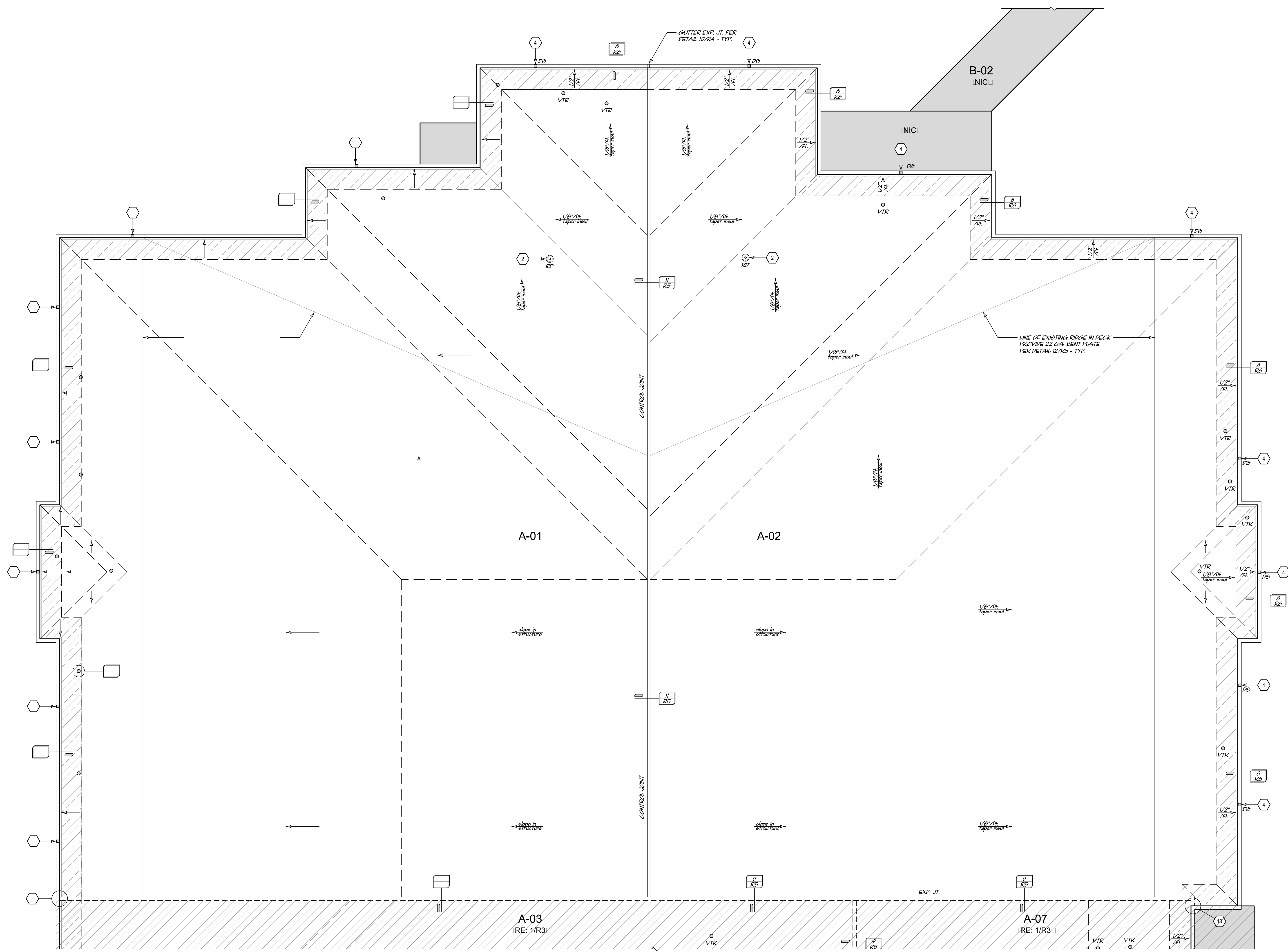

KEY PLAN
HOUSTON ELEMENTARY SCHOOL
NOT TO SCALE
PLAN NORTH

AUSTIN INDEPENDENT SCHOOL DISTRICT
ROOF REPLACEMENT
HOUSTON ELEMENTARY SCHOOL
5409 PONCIANA DR. AUSTIN, TX 78744
AISD PROJECT NO.: 18-0023-HOUST

REVISION SCHEDULE:

1.	
2.	
3.	
4.	
5.	
6.	
7.	



PARTIAL ROOF PLAN

DRAWN BY:
MWH
CHECKED BY:
JC
DATE:
09/21/2018
SHEET:

R2
OF
7

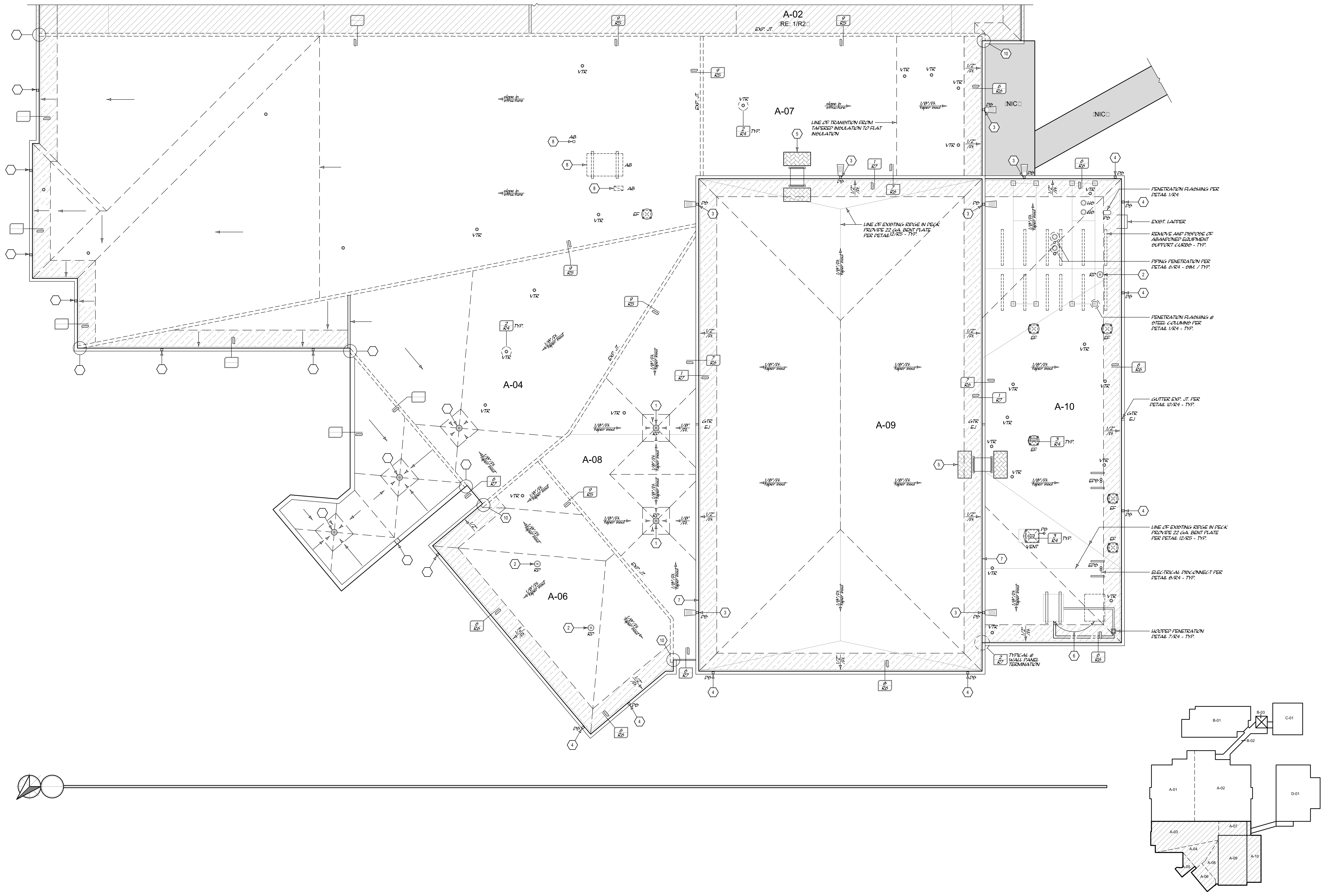

AUSTIN INDEPENDENT SCHOOL DISTRICT
ROOF REPLACEMENT
HOUSTON ELEMENTARY SCHOOL
5409 PONCIANA DR, AUSTIN, TX 78744
AISD PROJECT NO.: 18-0023-HOUST

REVISION SCHEDULE:

1.	
2.	
3.	
4.	
5.	
6.	
7.	



PARTIAL ROOF PLAN

DRAWN BY:
MWH
CHECKED BY:
JC
DATE:
09/21/2018
SHEET:

R3
OF
7



KEY PLAN
HOUSTON ELEMENTARY SCHOOL
NOT TO SCALE
PLAN NORTH

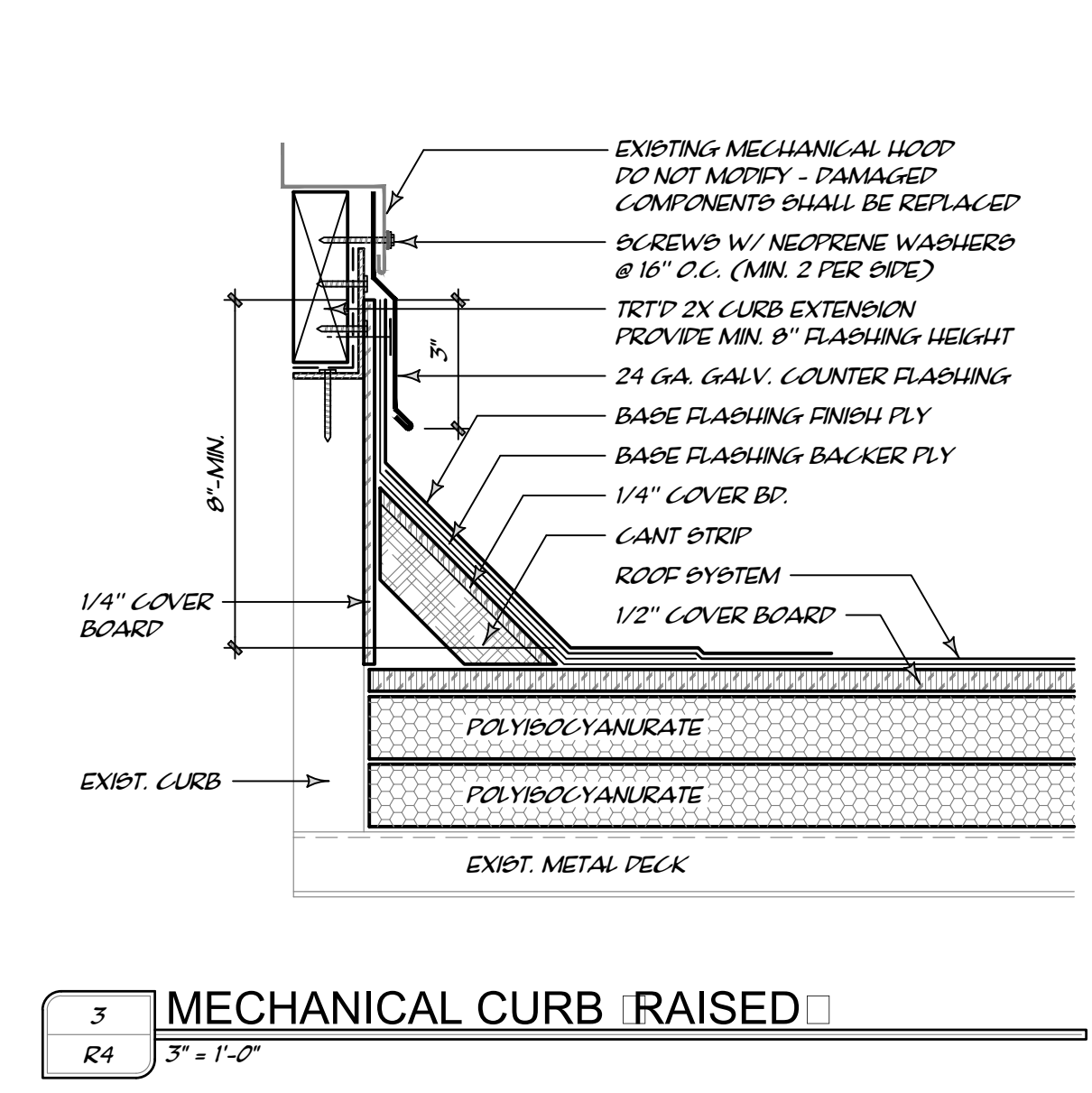
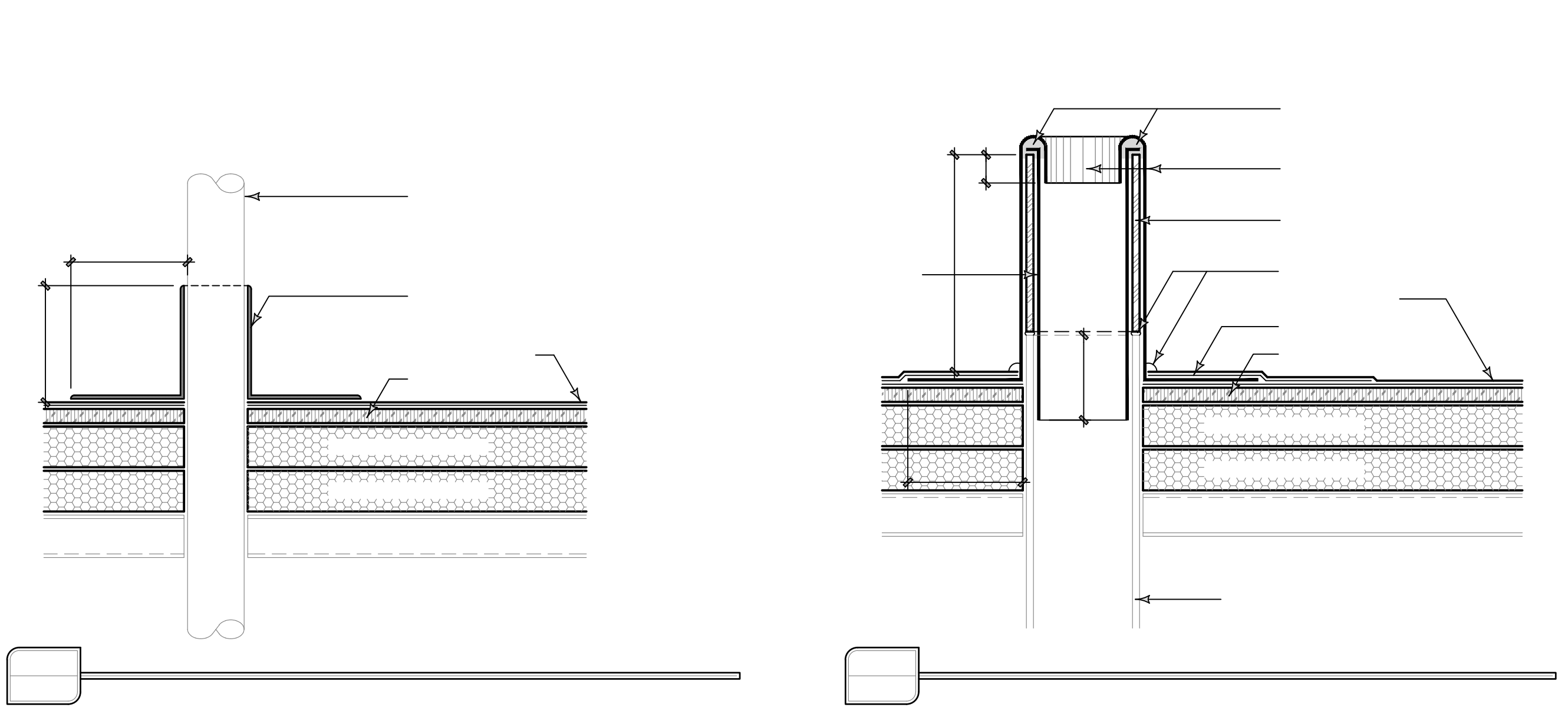

3 MECHANICAL CURB RAISED
R4 3" x 1'-0"

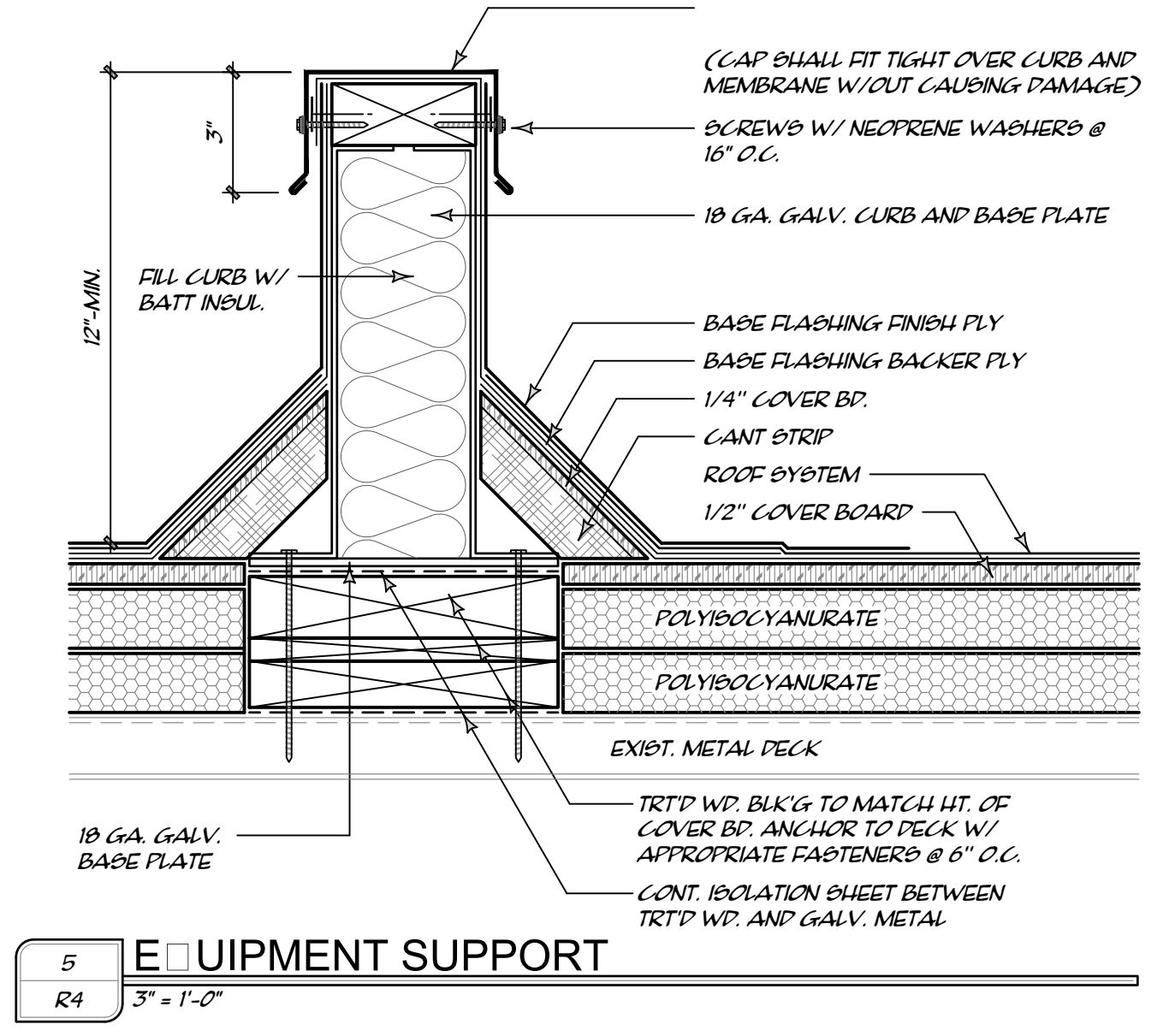

5 EQUIPMENT SUPPORT
R4 3" x 1'-0"

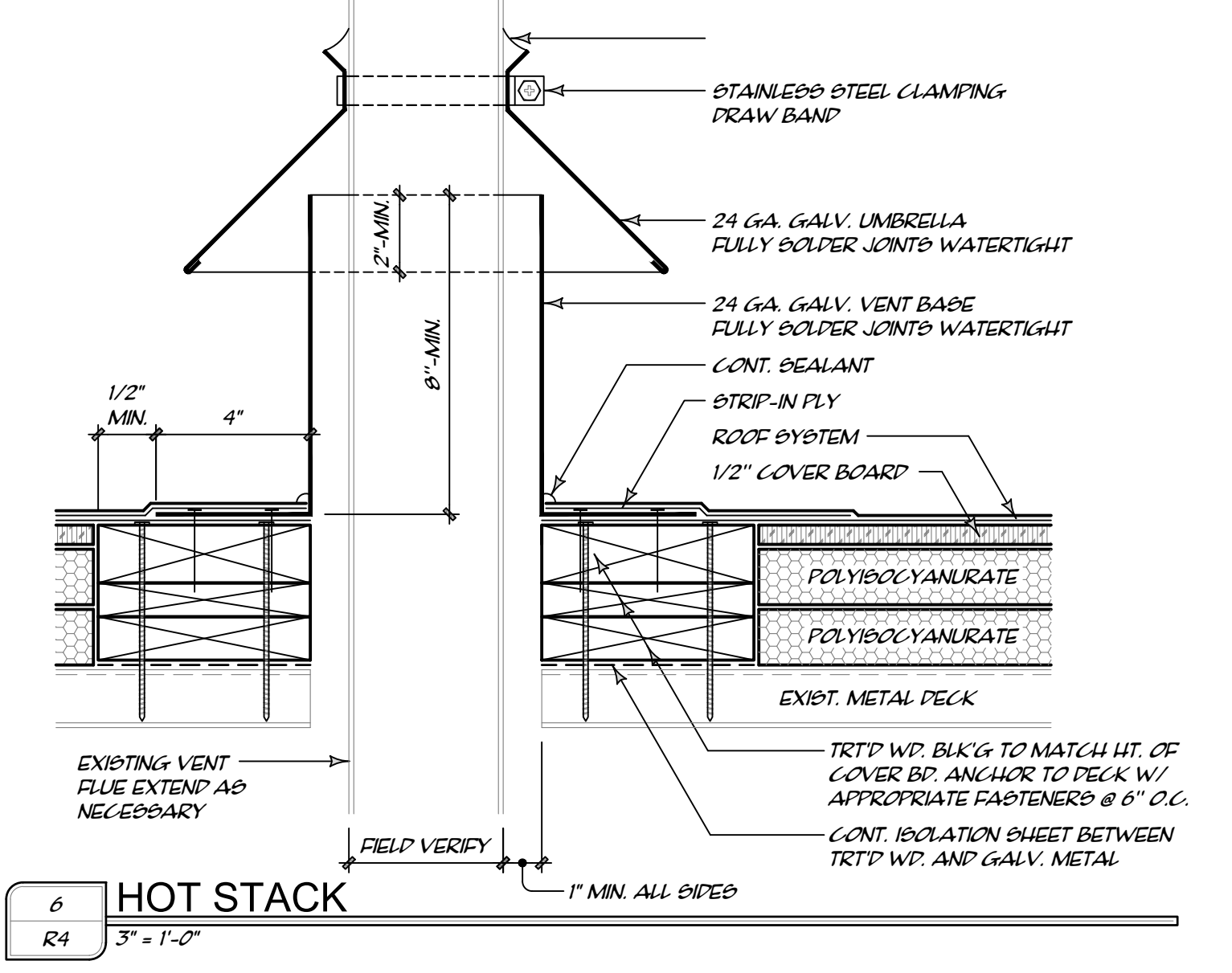

6 HOT STACK
R4 3" x 1'-0"

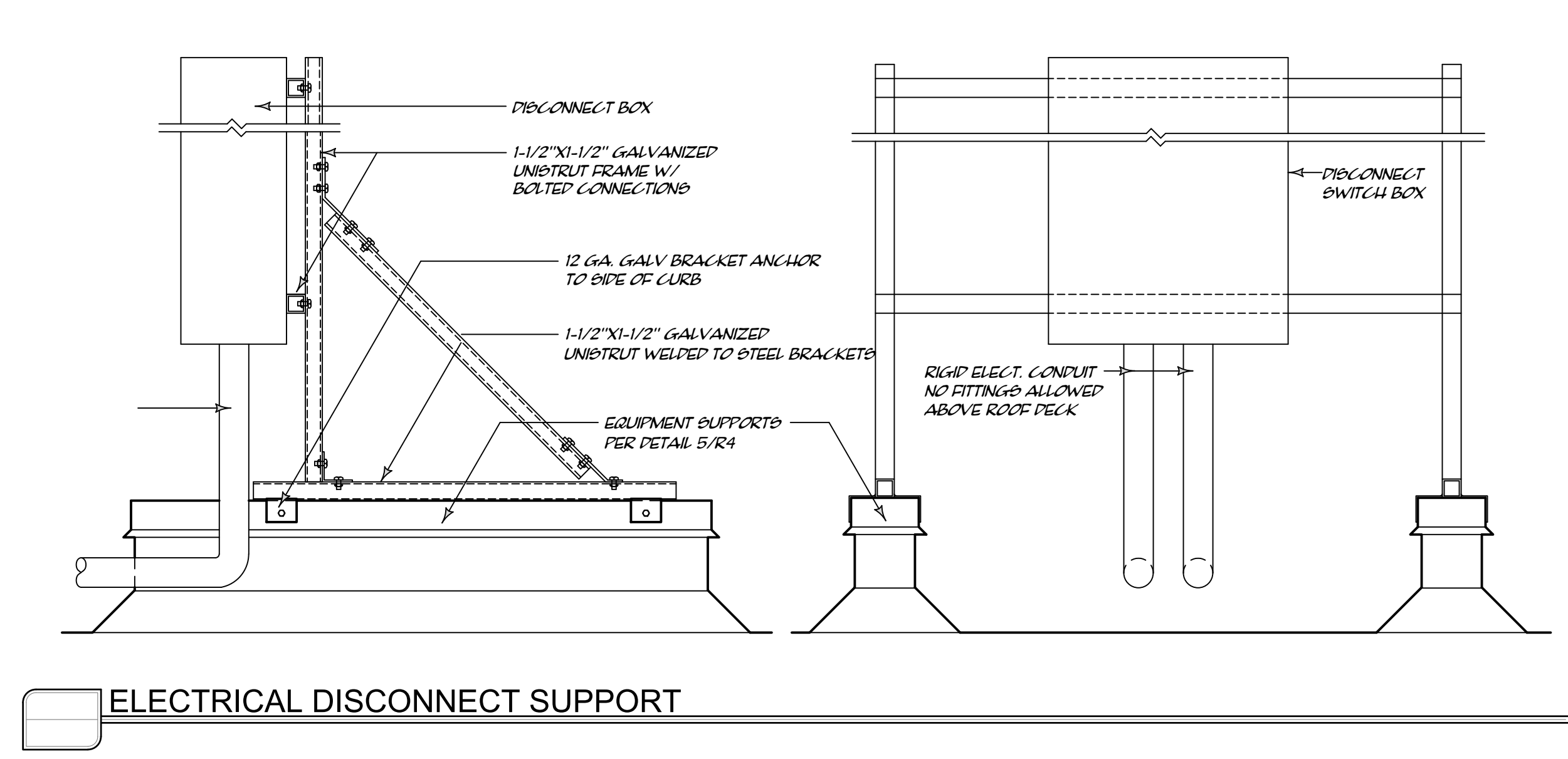
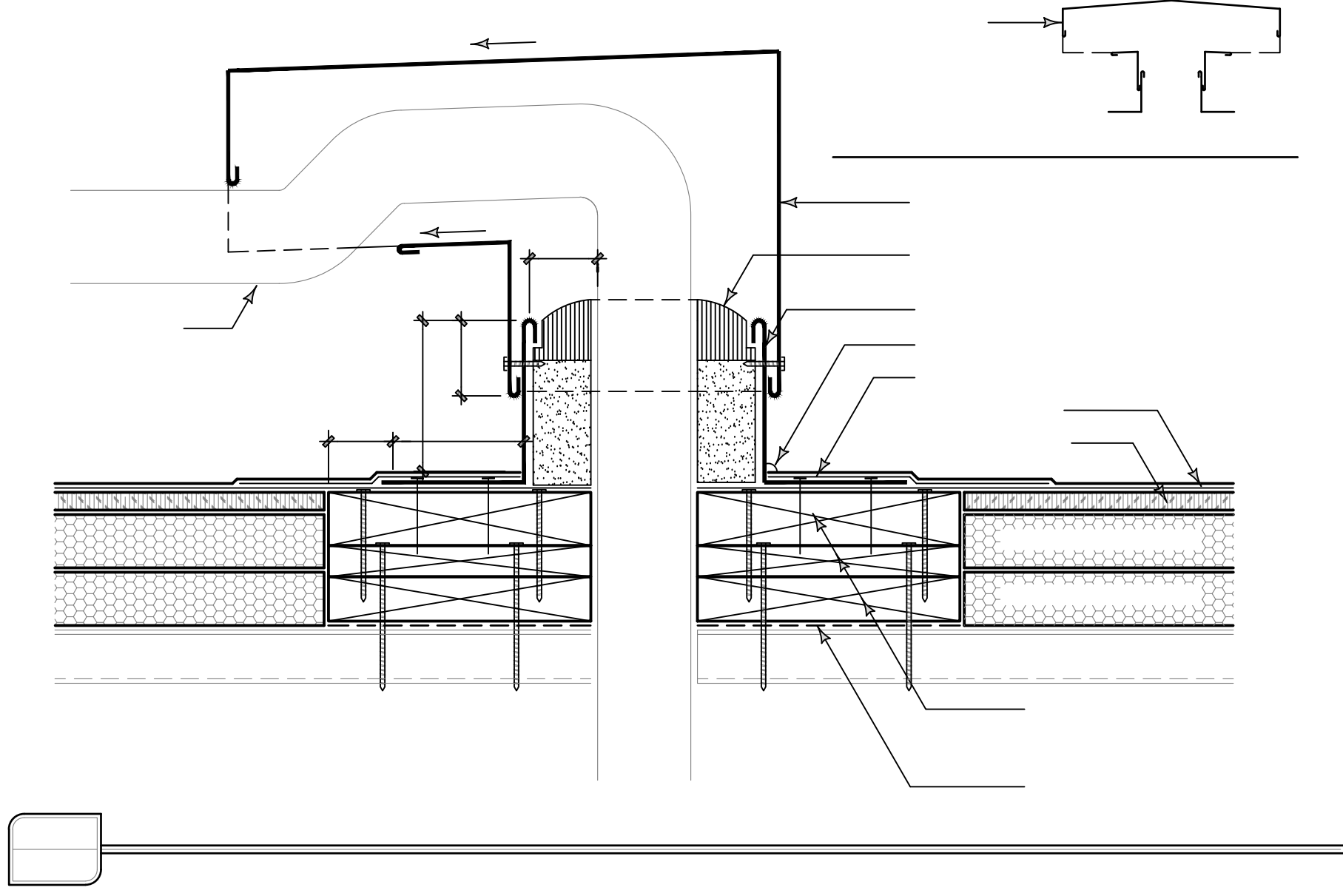

ELECTRICAL DISCONNECT SUPPORT

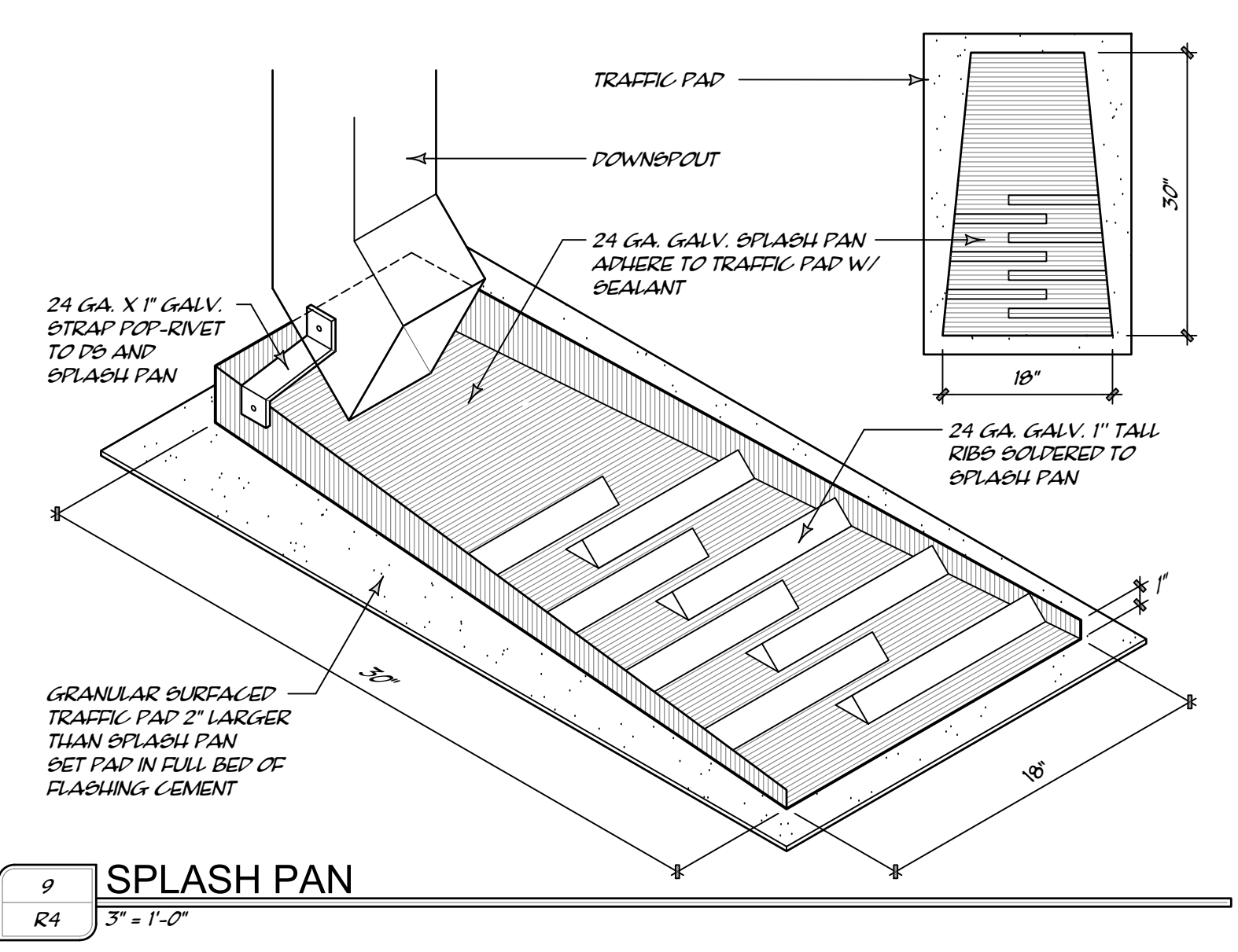

9 SPLASH PAN
R4 3" x 1'-0"

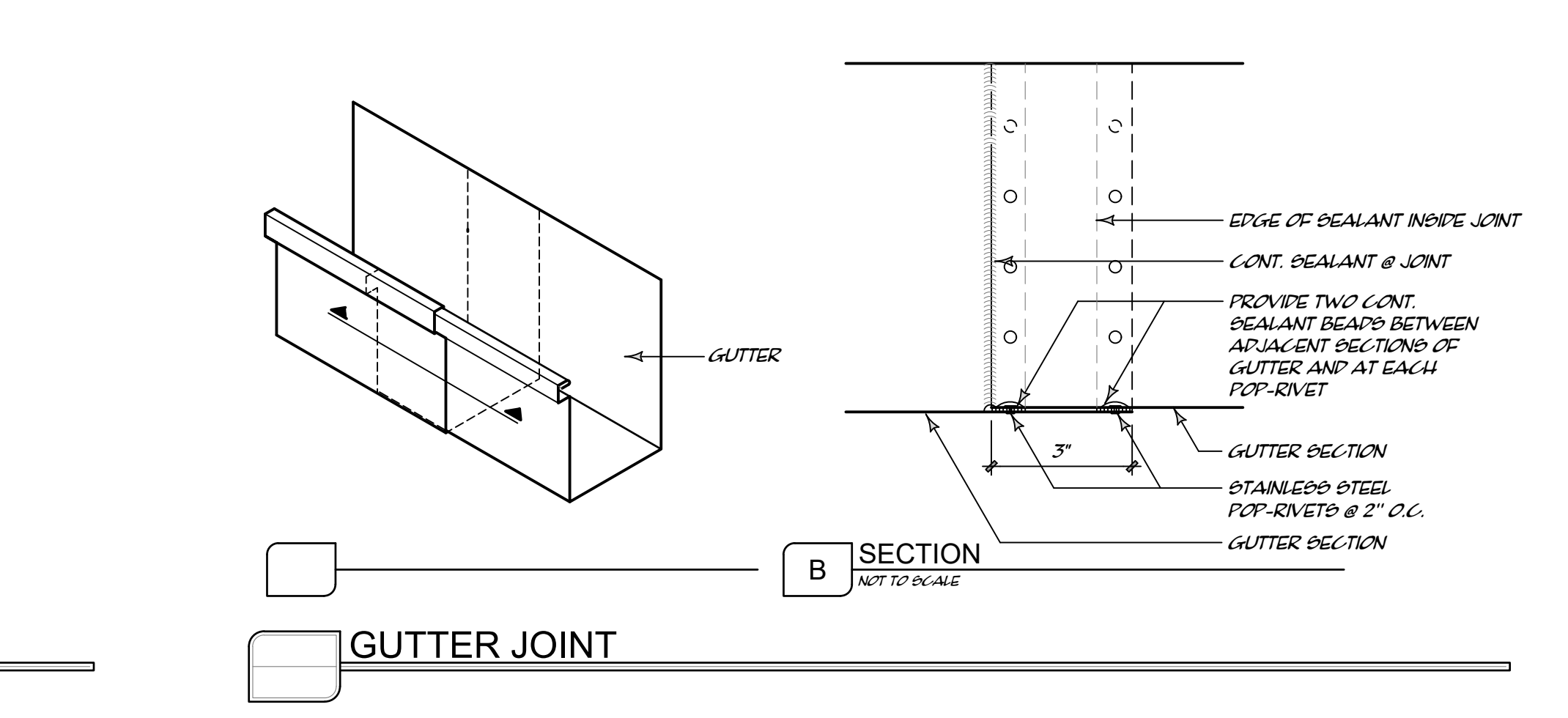
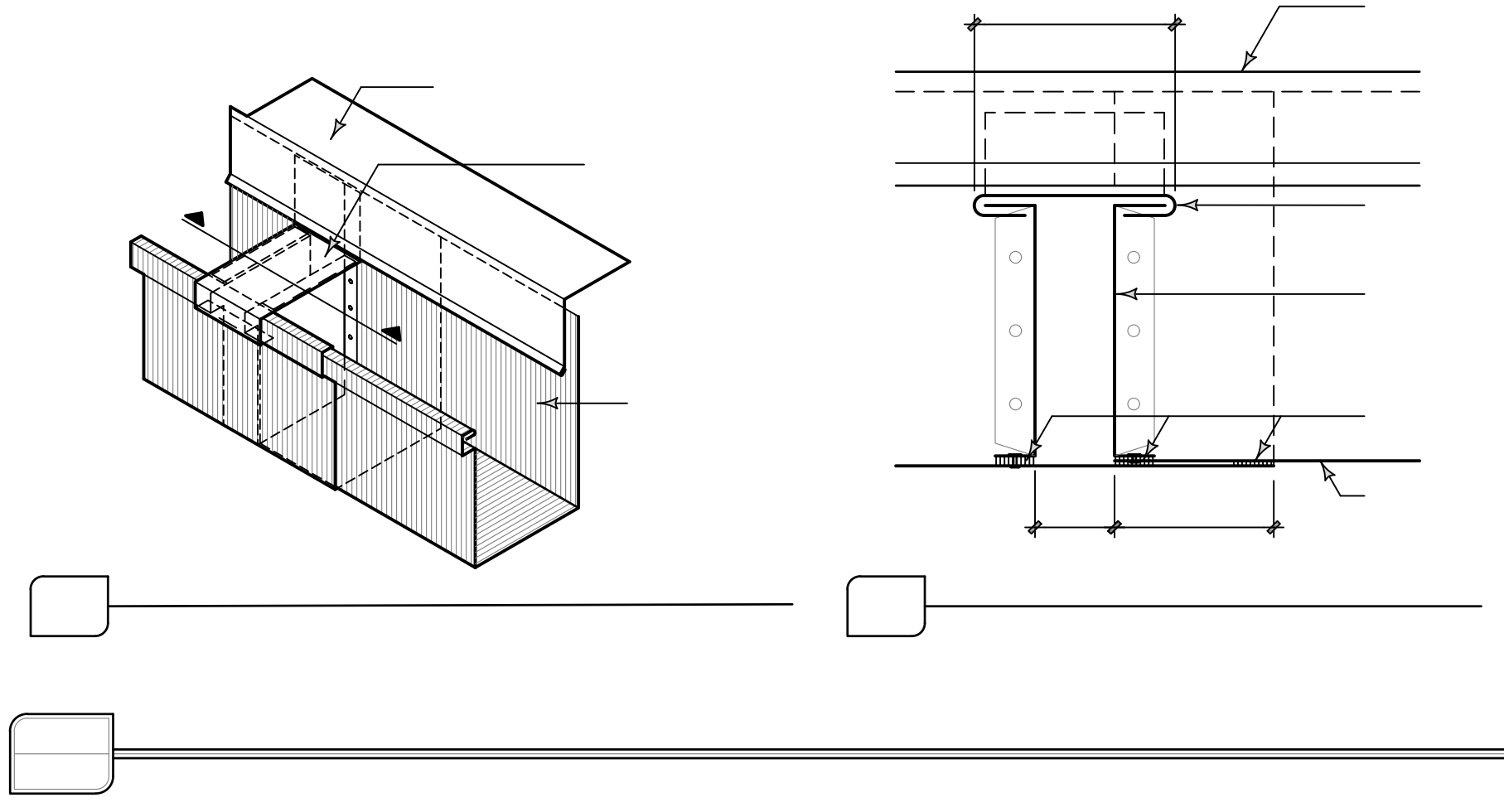

B SECTION NOT TO SCALE
GUTTER JOINT

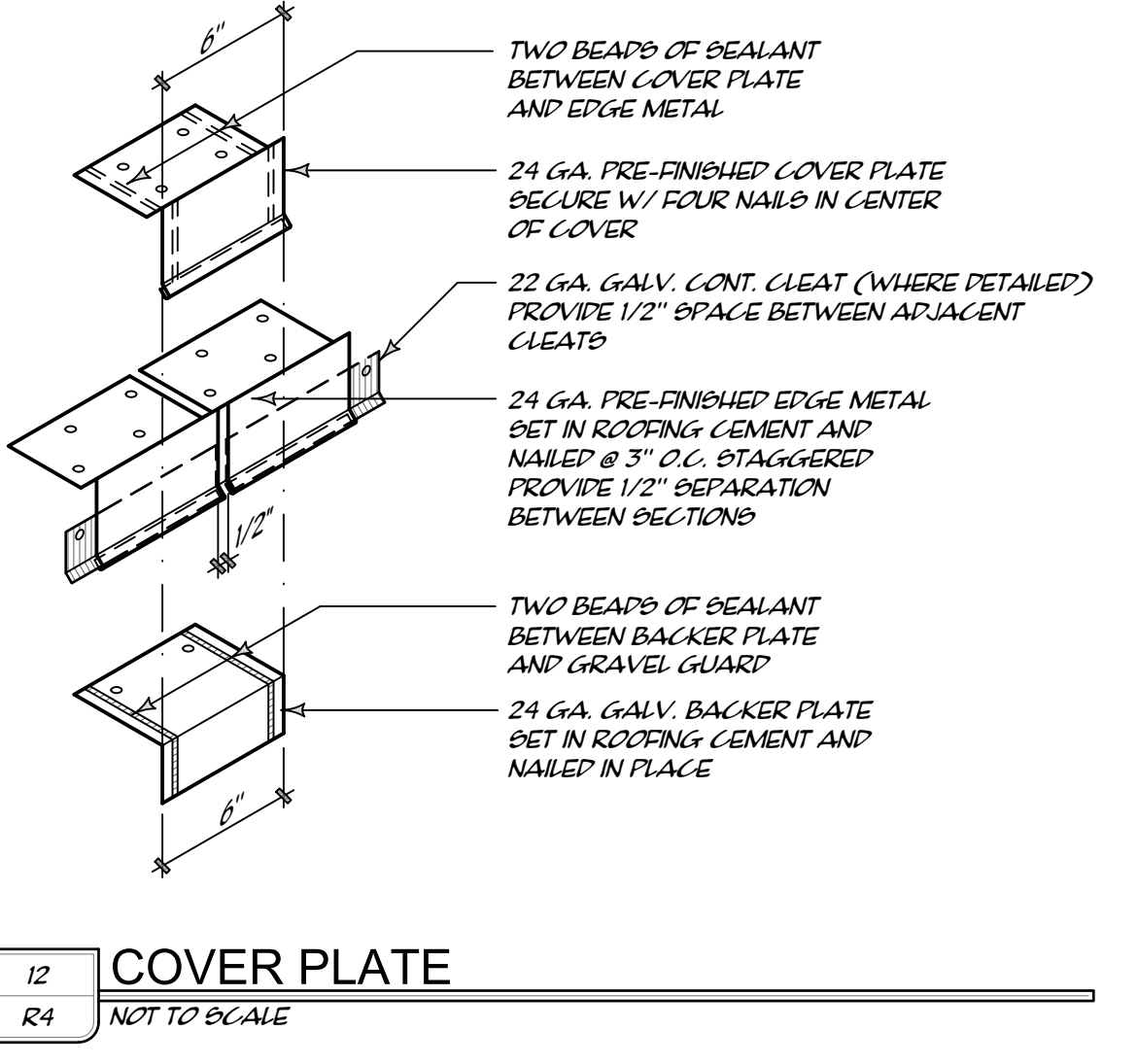

12 COVER PLATE
R4 NOT TO SCALE

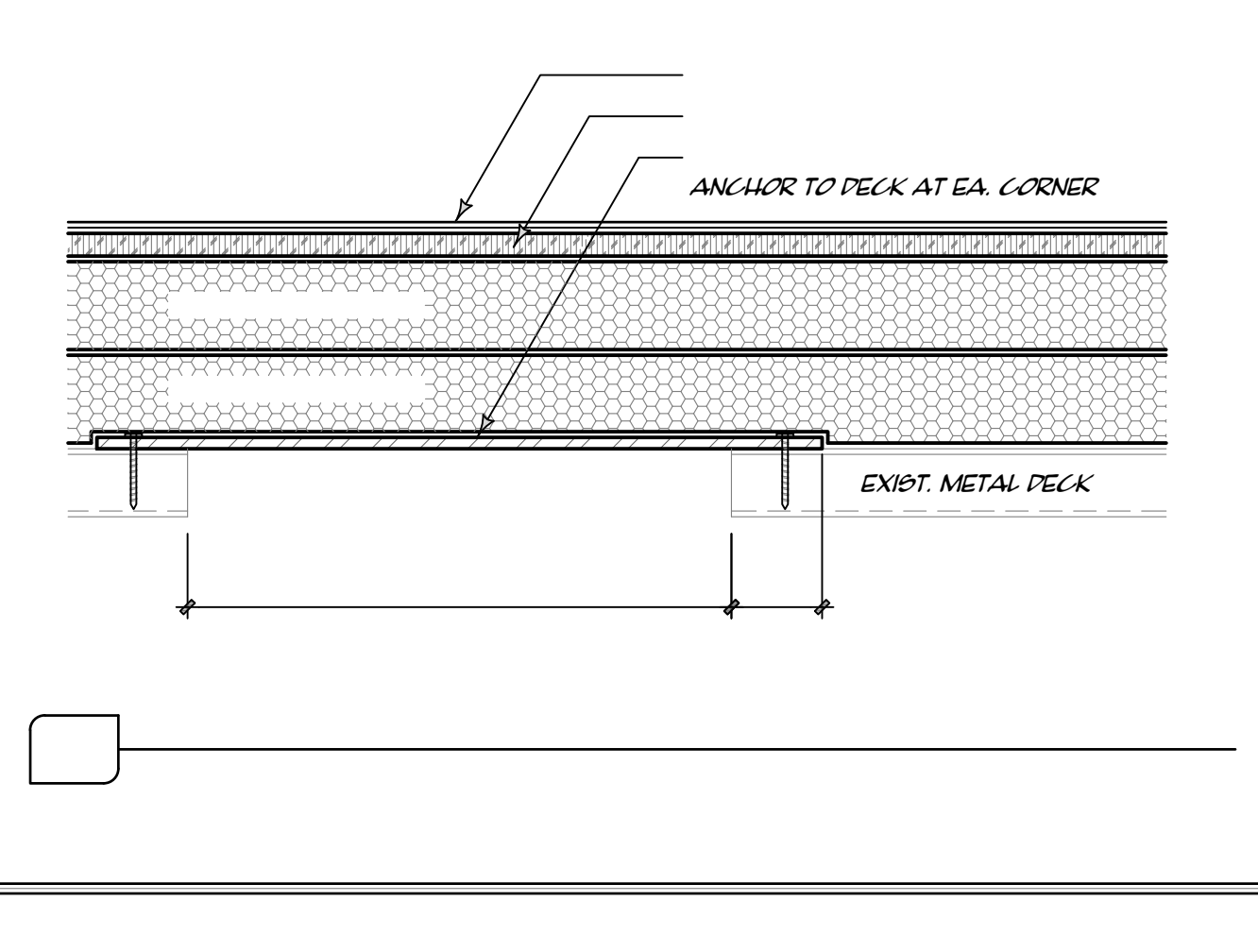
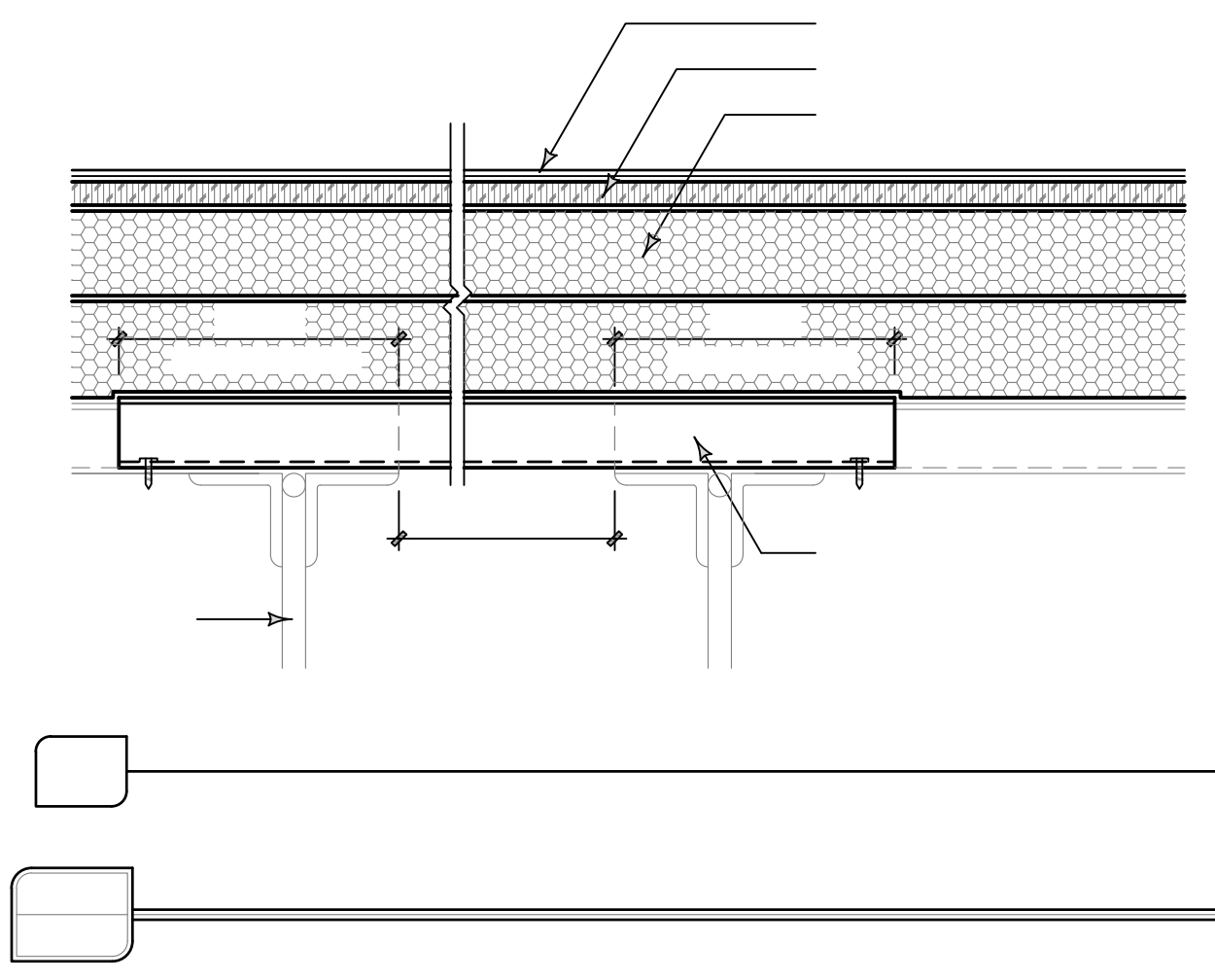

AUSTIN INDEPENDENT SCHOOL DISTRICT
ROOF REPLACEMENT
HOUSTON ELEMENTARY SCHOOL
5409 PONCIANA DR, AUSTIN, TX 78744
AUSD PROJECT NO.: 18-0023-HOUST

REVISION SCHEDULE:

1.	
2.	
3.	
4.	
5.	
6.	
7.	



DISCONNECT, RAISE AND RECONNECT EXISTING GAS LINES, ELECTRICAL LINES, ETC. AS REQUIRED TO ACCOMMODATE HEIGHT OF PIPE SUPPORT.
2. SPACE PIPE SUPPORTS @ 8'-0" O.C.
3. PROVIDE PIPE SUPPORTS WITHIN 12"-18" OF CORNERS AND/OR TEE INTERSECTIONS
4. PROVIDE PIPE RETAINER BRACKETS

DISCONNECT, RAISE AND RECONNECT EXISTING CONDENSATE LINES, ETC.

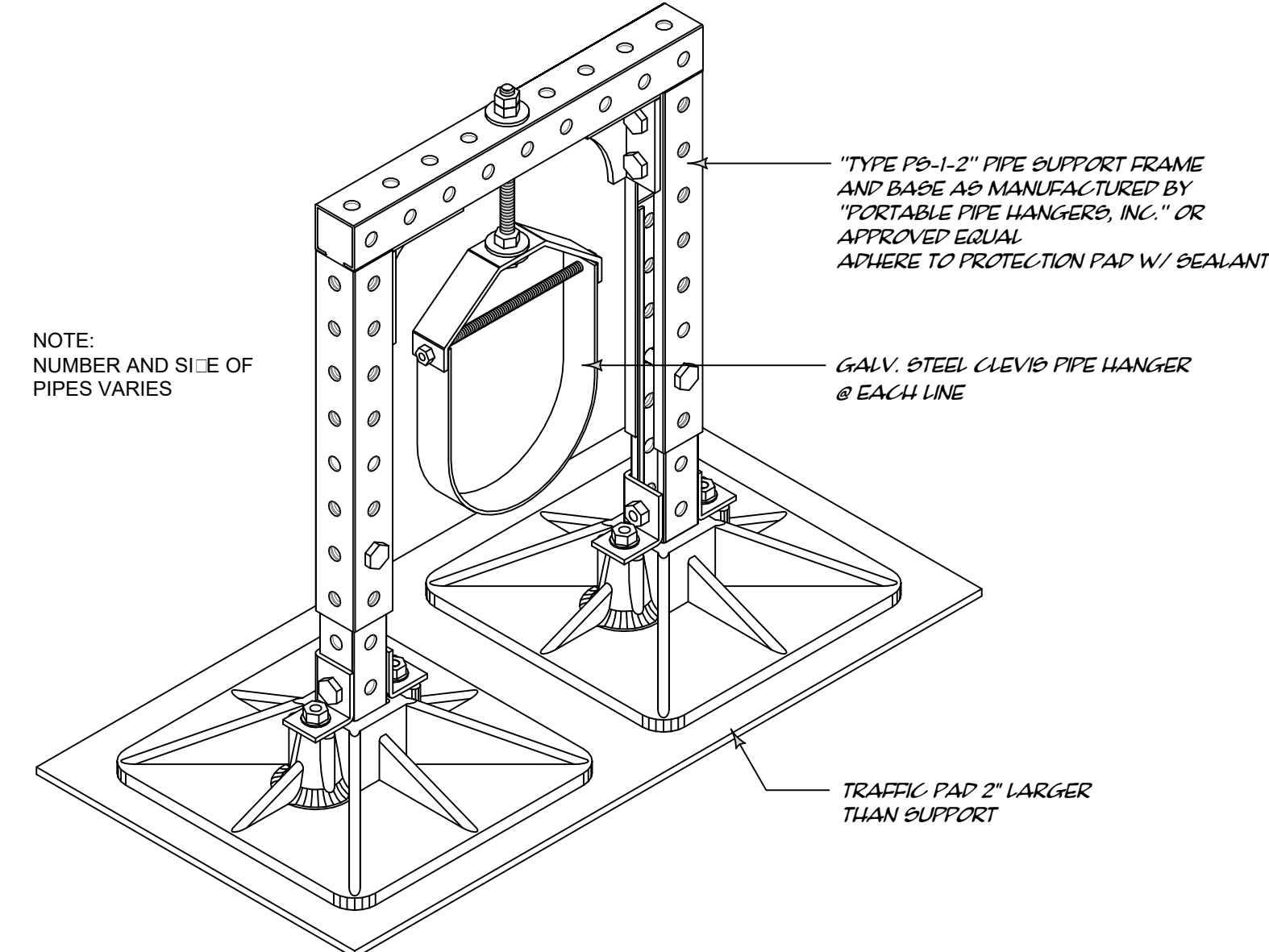
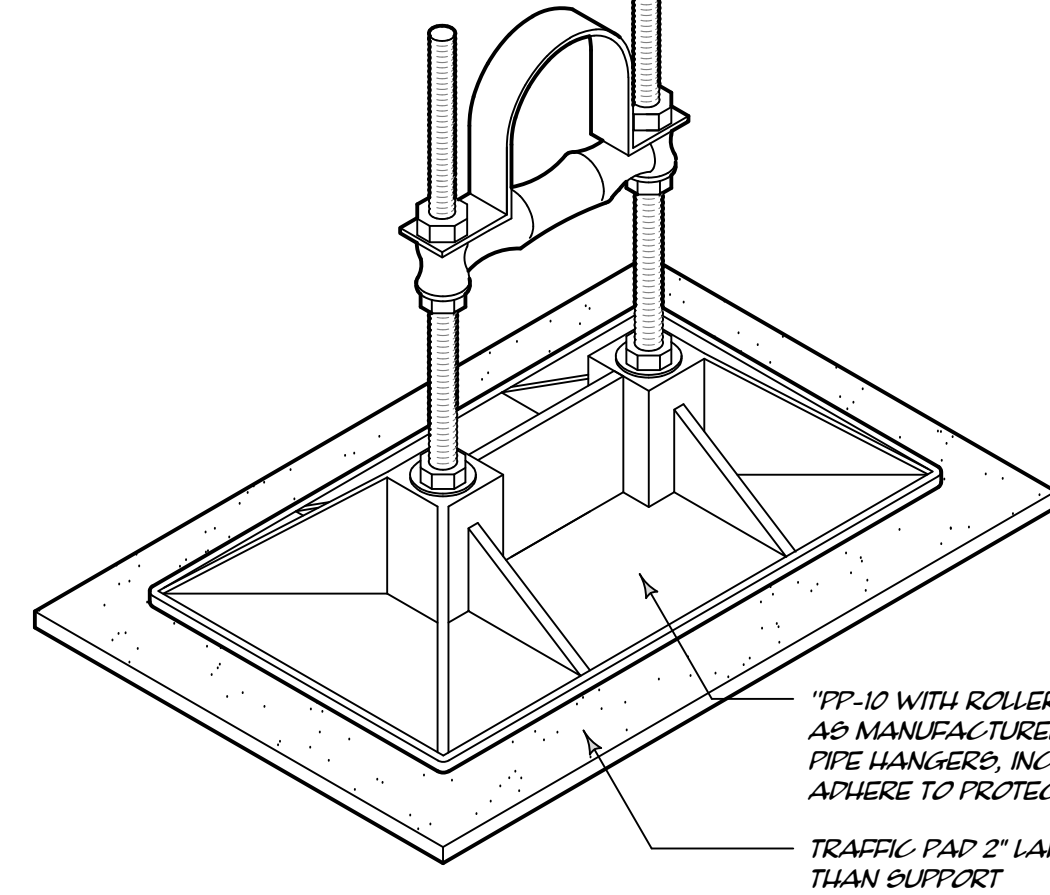
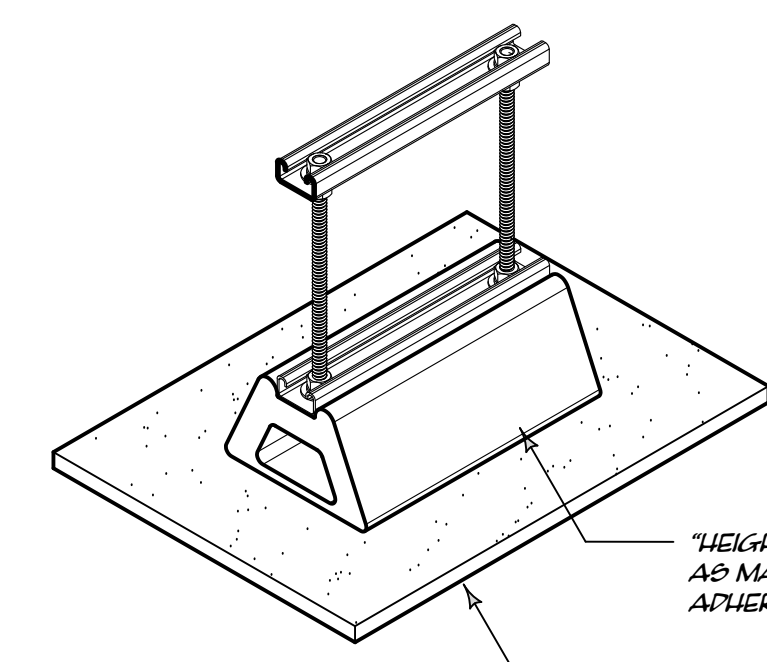
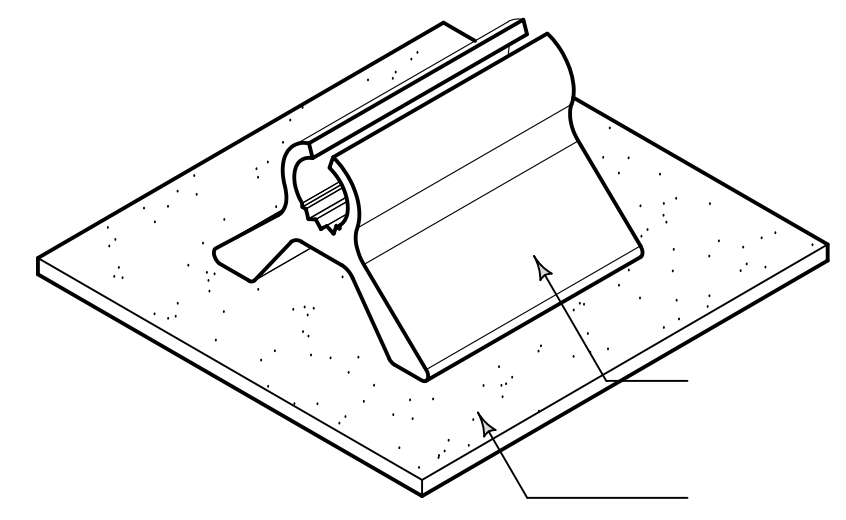

PIPE SUPPORT - ADJUSTABLE HEIGHT TYPE "A"
RS 3" x 1'-0"

PIPE SUPPORT - ADJUSTABLE HEIGHT TYPE "B"
RS 3" x 1'-0"

PIPE SUPPORT - ADJUSTABLE HEIGHT TYPE "B"
RS 3" x 1'-0"

HANGING PIPE SUPPORT TYPE "C"
RS NOT TO SCALE

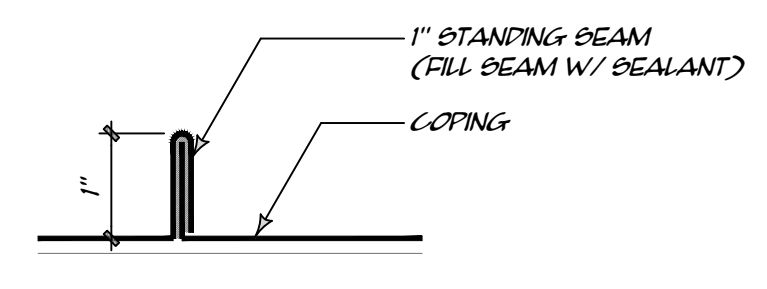
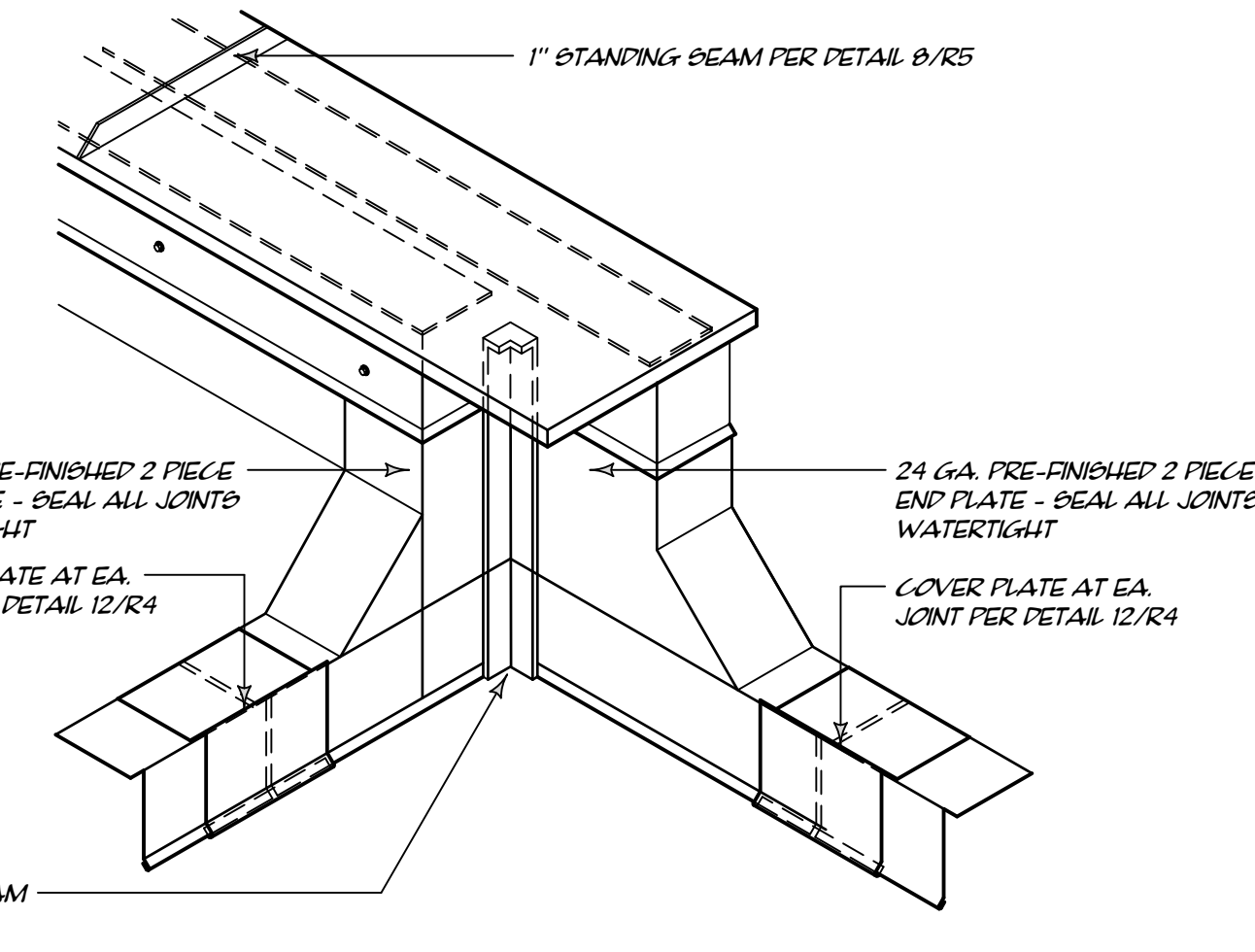
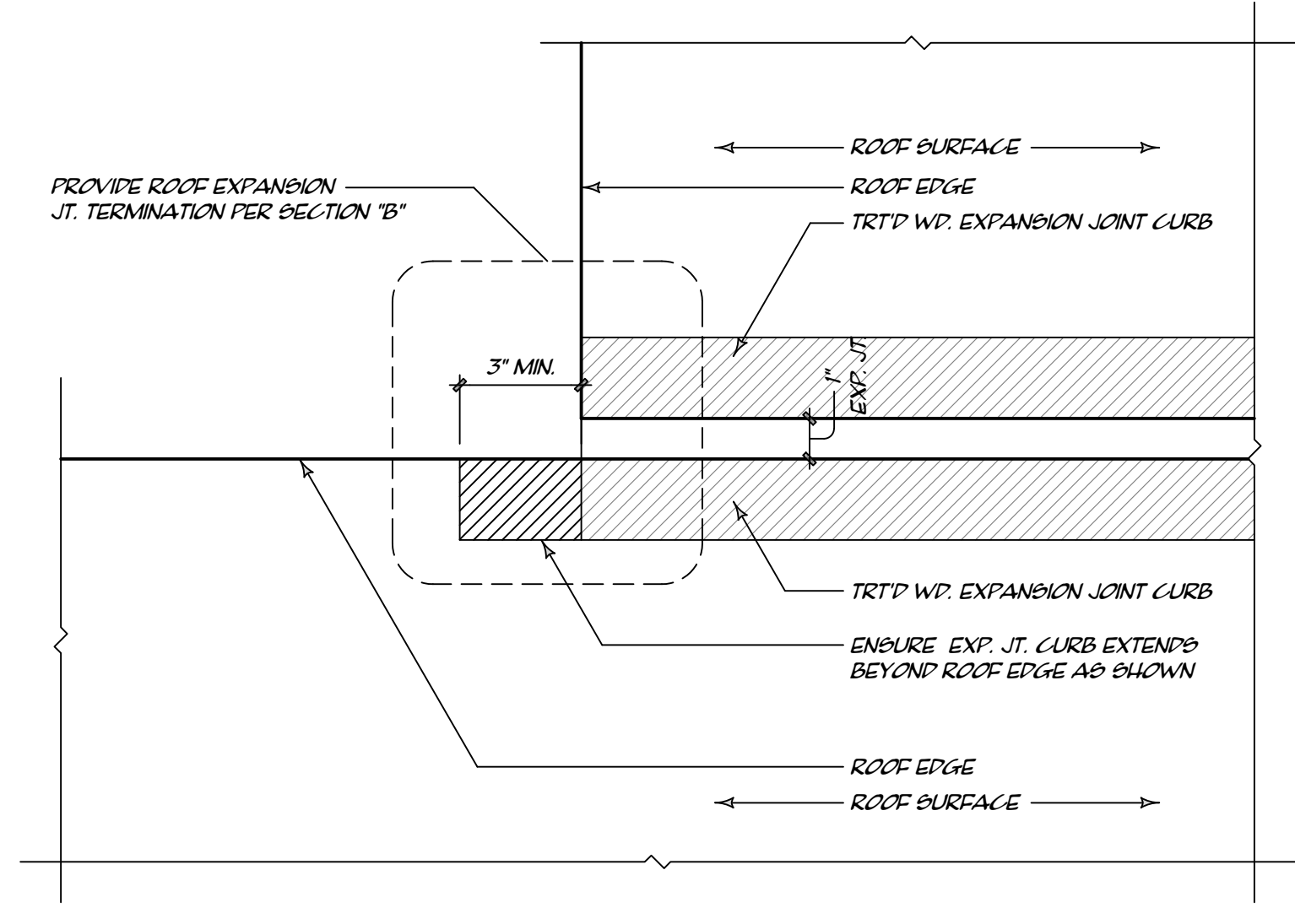
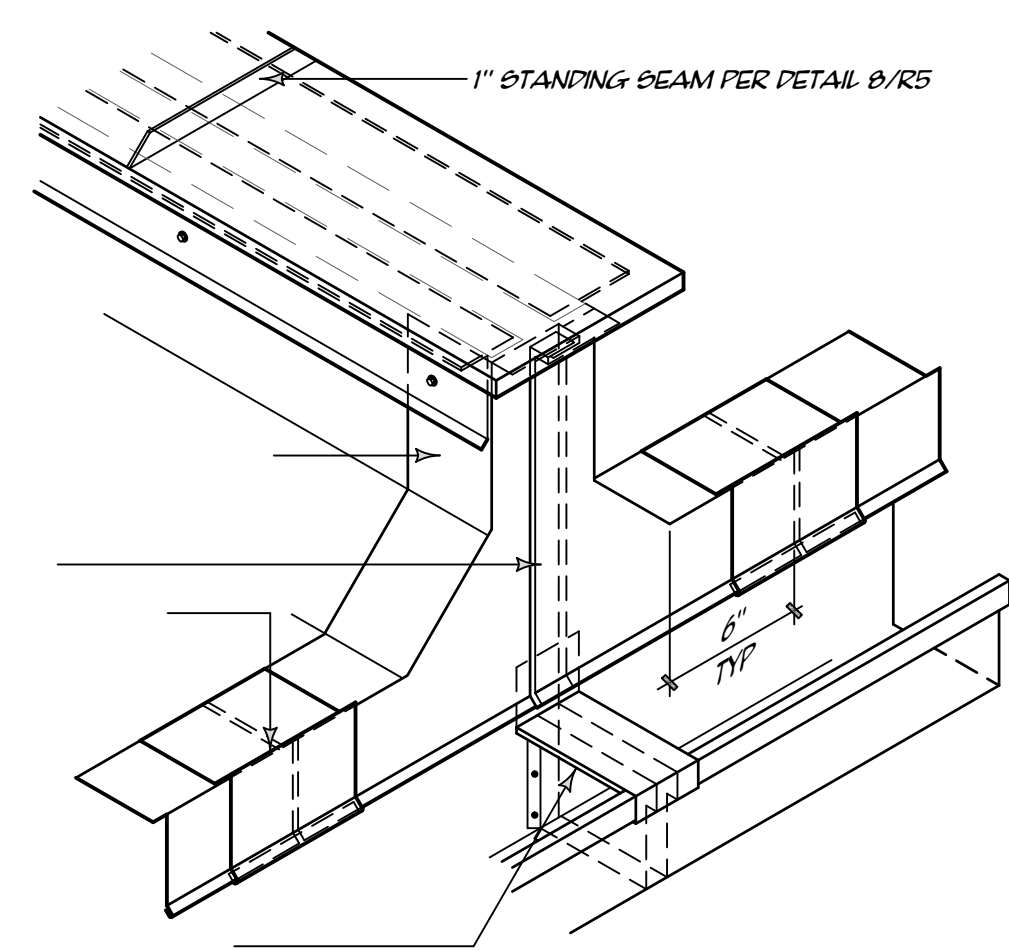
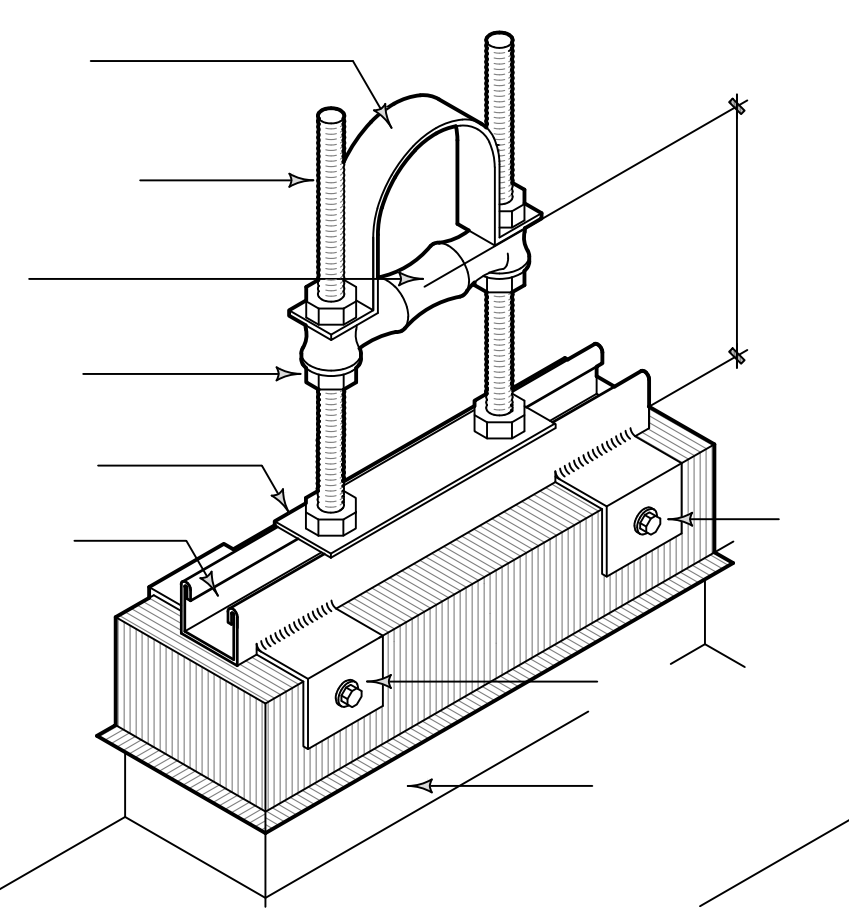

EXPANSION JOINT TERMINATION
RS 3" x 1'-0"

EXPANSION JOINT TERMINATION
RS 3" x 1'-0"

PLAN VIEW
NET TO SCALE
7 ROOF TO ROOF EXP. JT. TERMINATION @ INSIDE CORNER
RS 3" x 1'-0"

ISOMETRIC
NET TO SCALE
8 STANDING SEAM JOINT
RS NOT TO SCALE

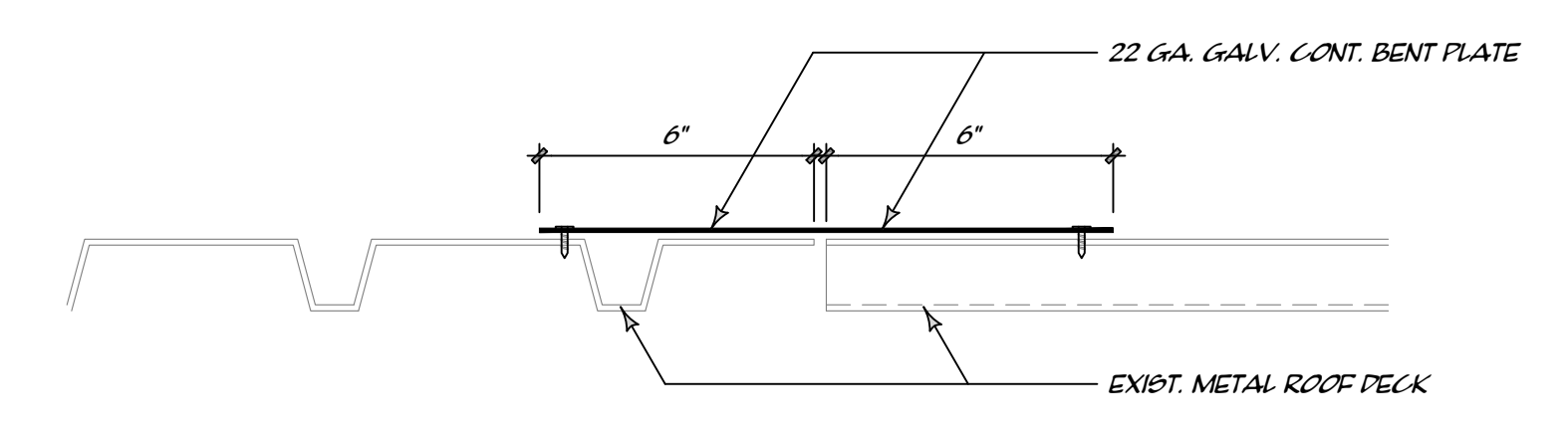
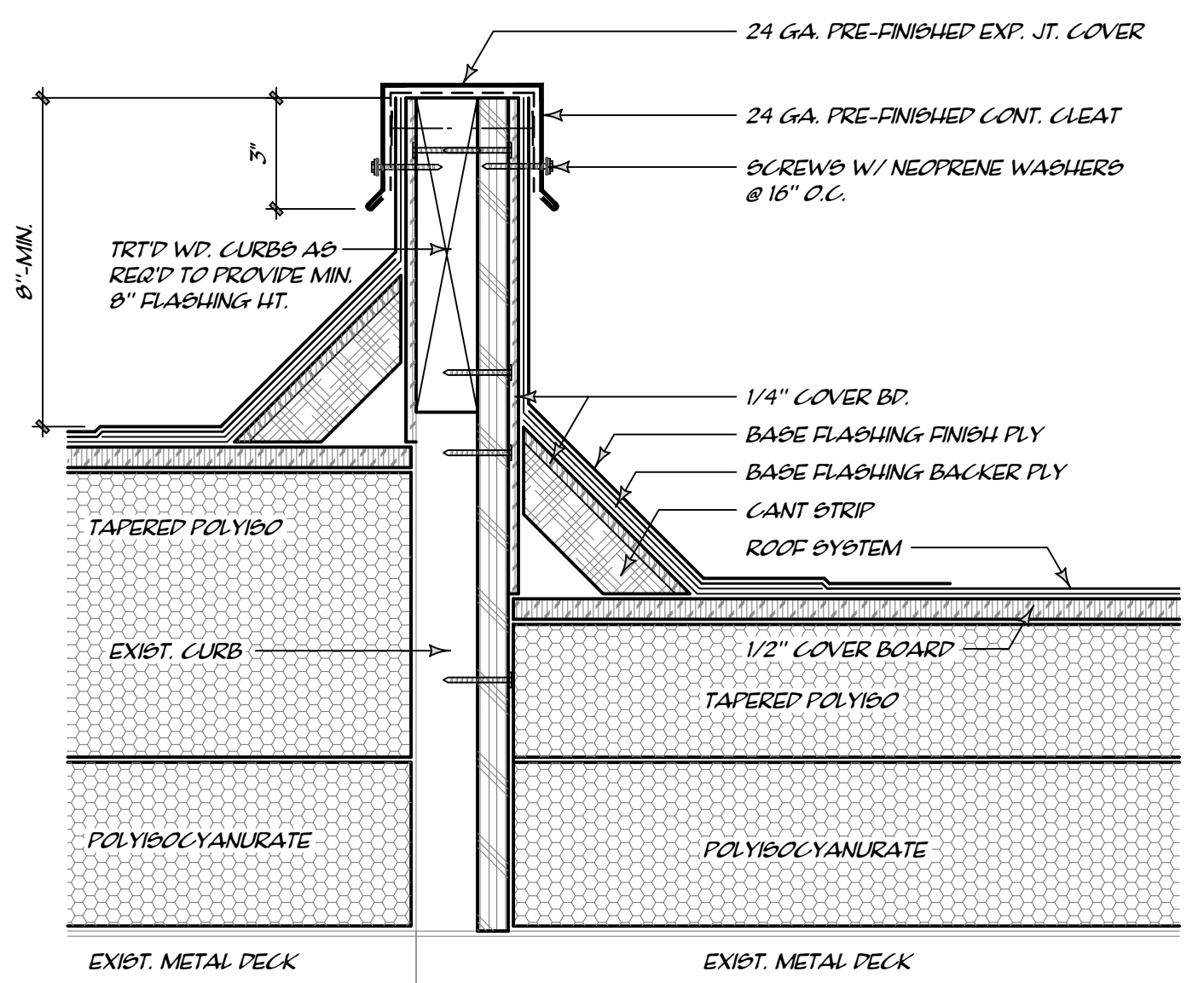
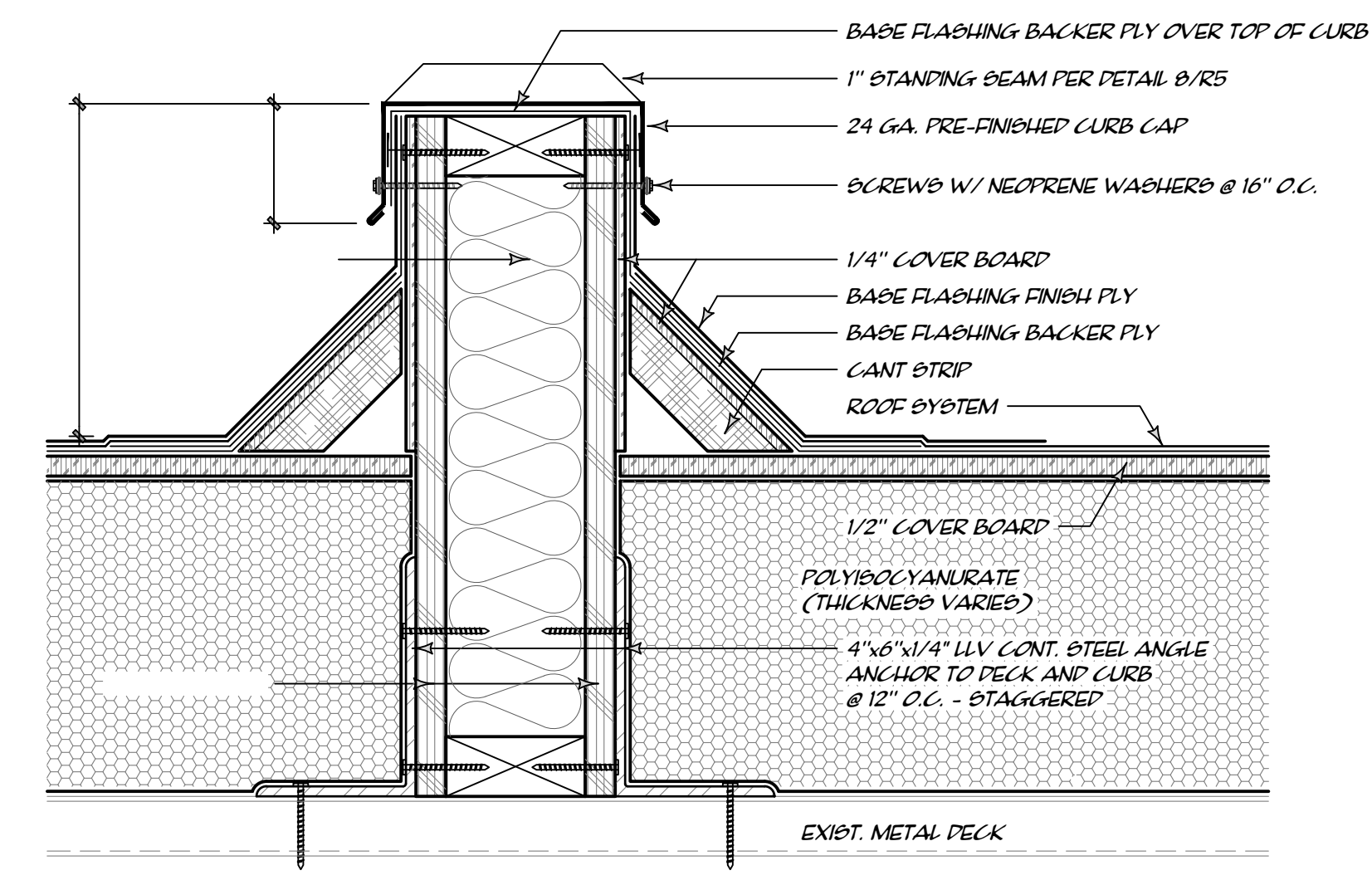
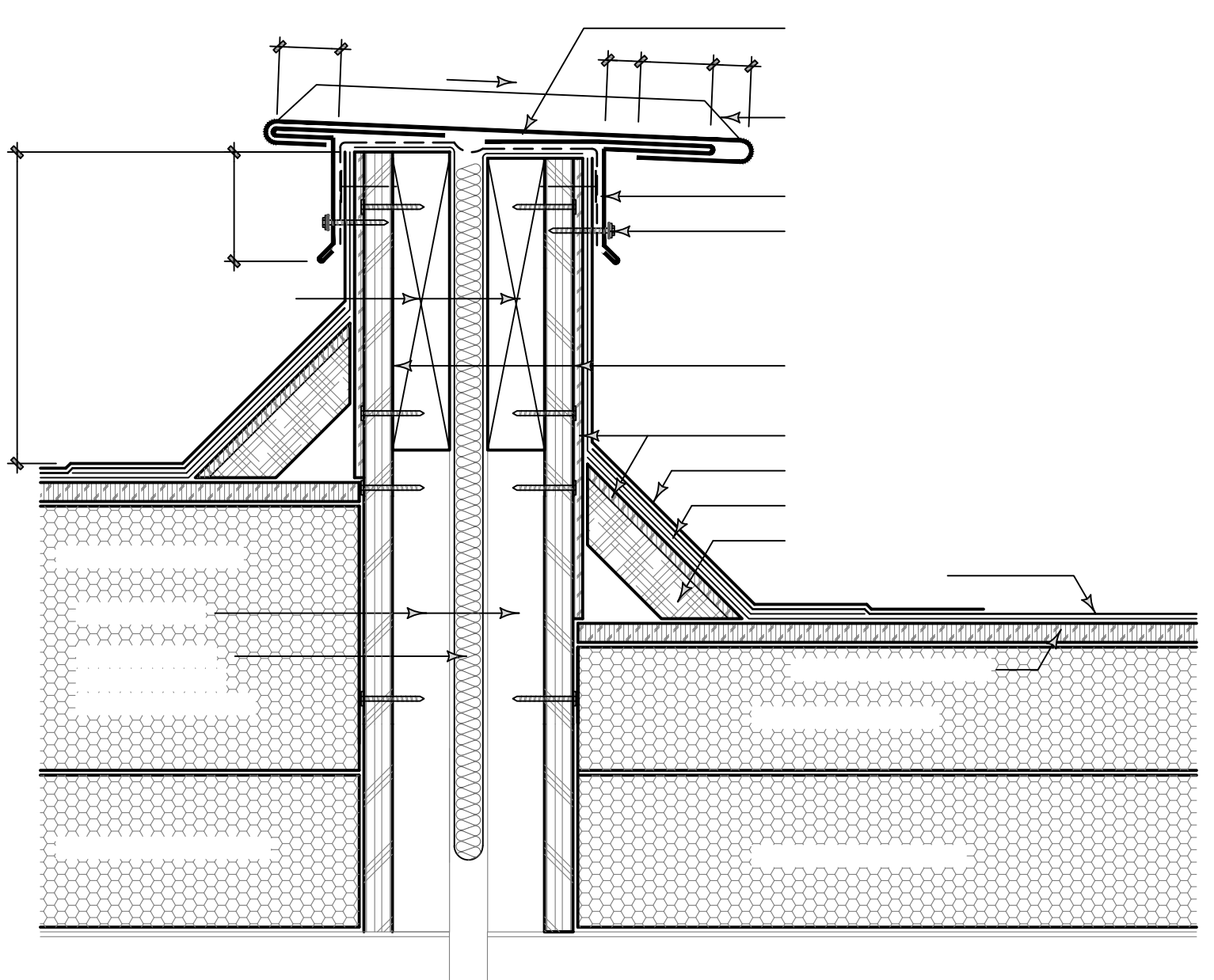

CONTROL JOINT
RS 3" x 1'-0"

CONTROL JOINT
RS 3" x 1'-0"

CONTROL JOINT
RS 3" x 1'-0"

TRANSITION IN DECK
RS 3" x 1'-0"

AUSTIN INDEPENDENT SCHOOL DISTRICT
ROOF REPLACEMENT
HOUSTON ELEMENTARY SCHOOL
5409 PONCIANA DR, AUSTIN, TX 78744
AUSD PROJECT NO.: 18-0023-HOUST

REVISION SCHEDULE:	
1.	
2.	
3.	
4.	
5.	
6.	
7.	



ROOFING DETAILS
DRAWN BY: MWH
CHECKED BY: JC
DATE: 09/21/2018
SHEET:

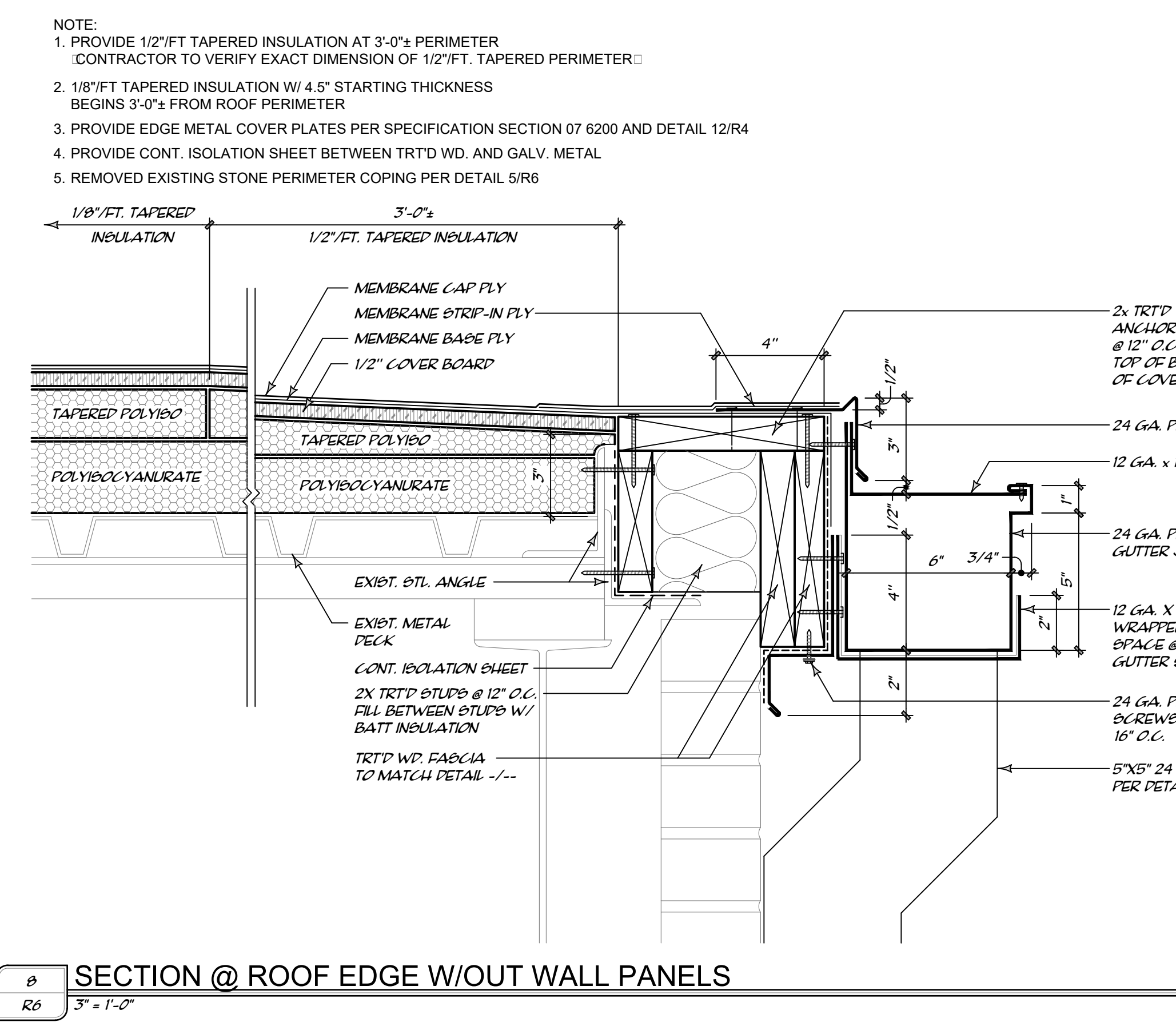
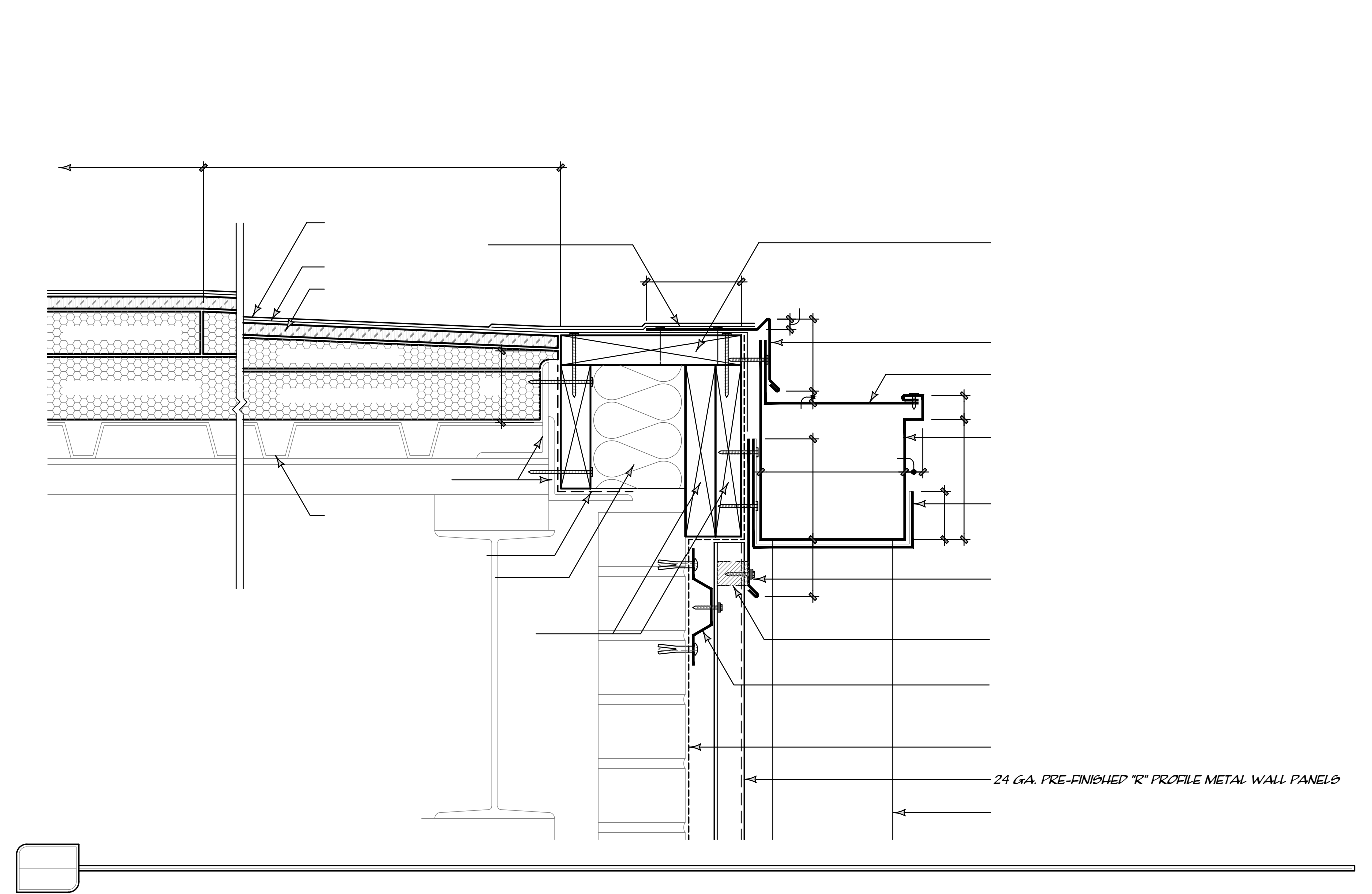
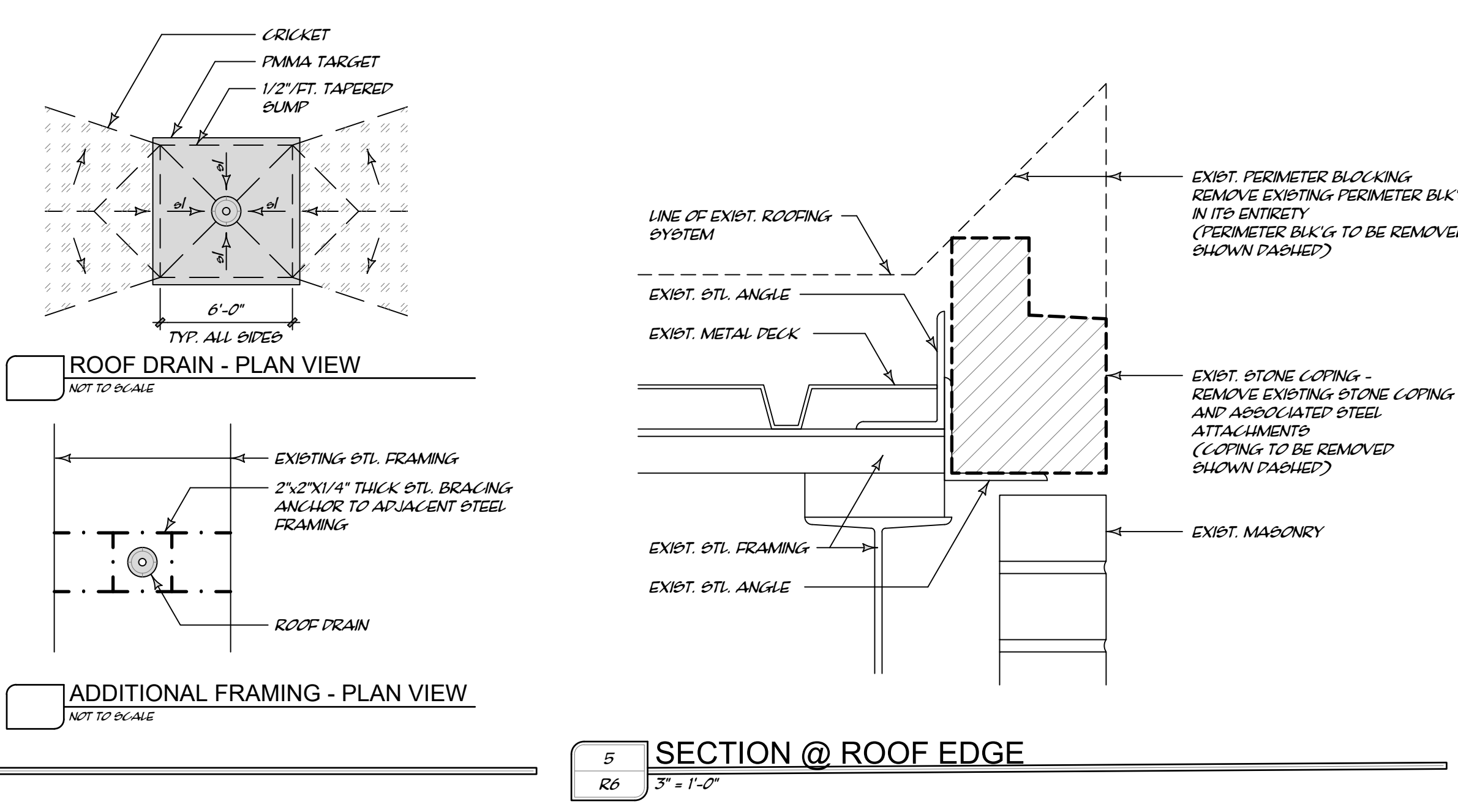
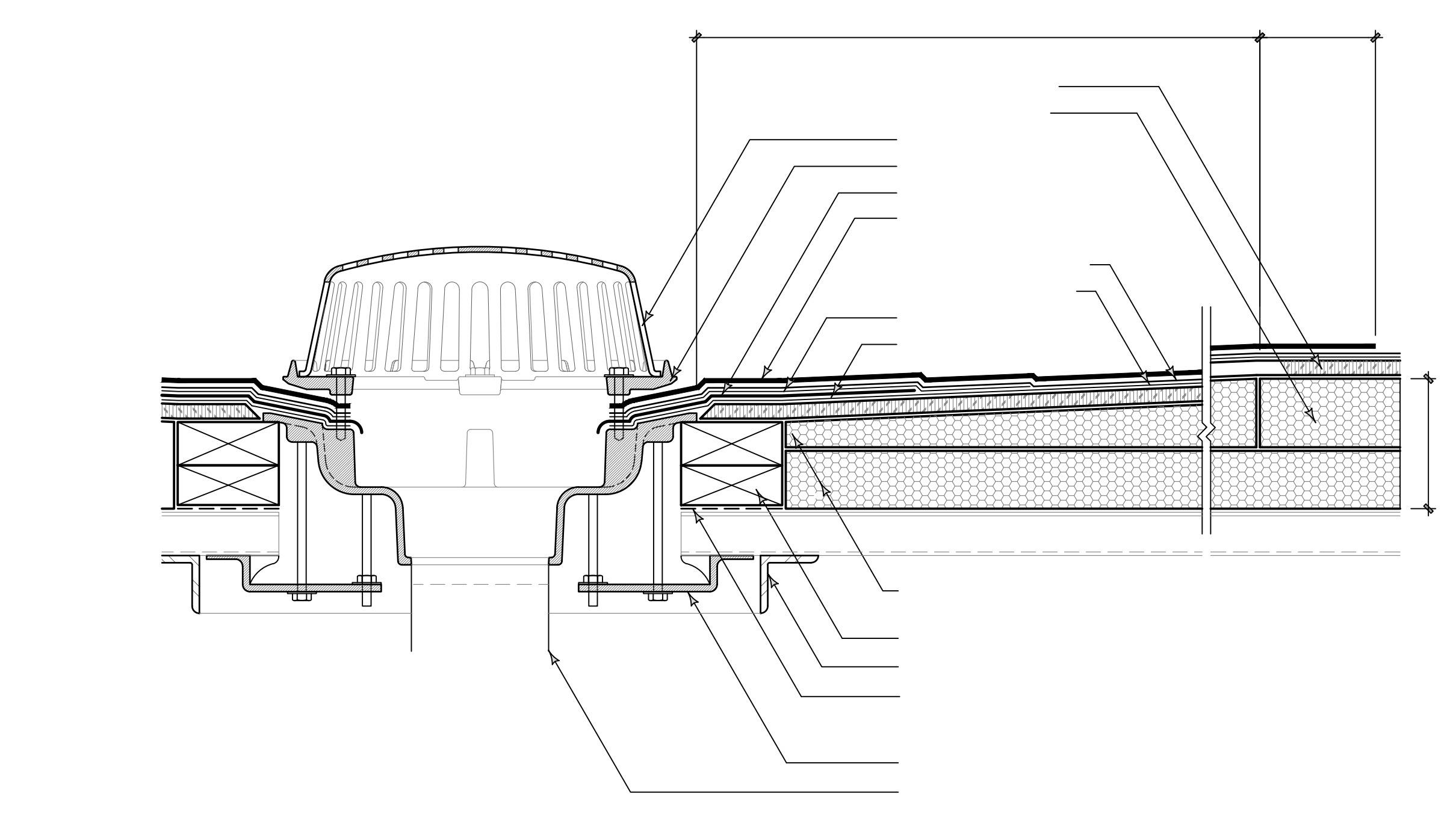
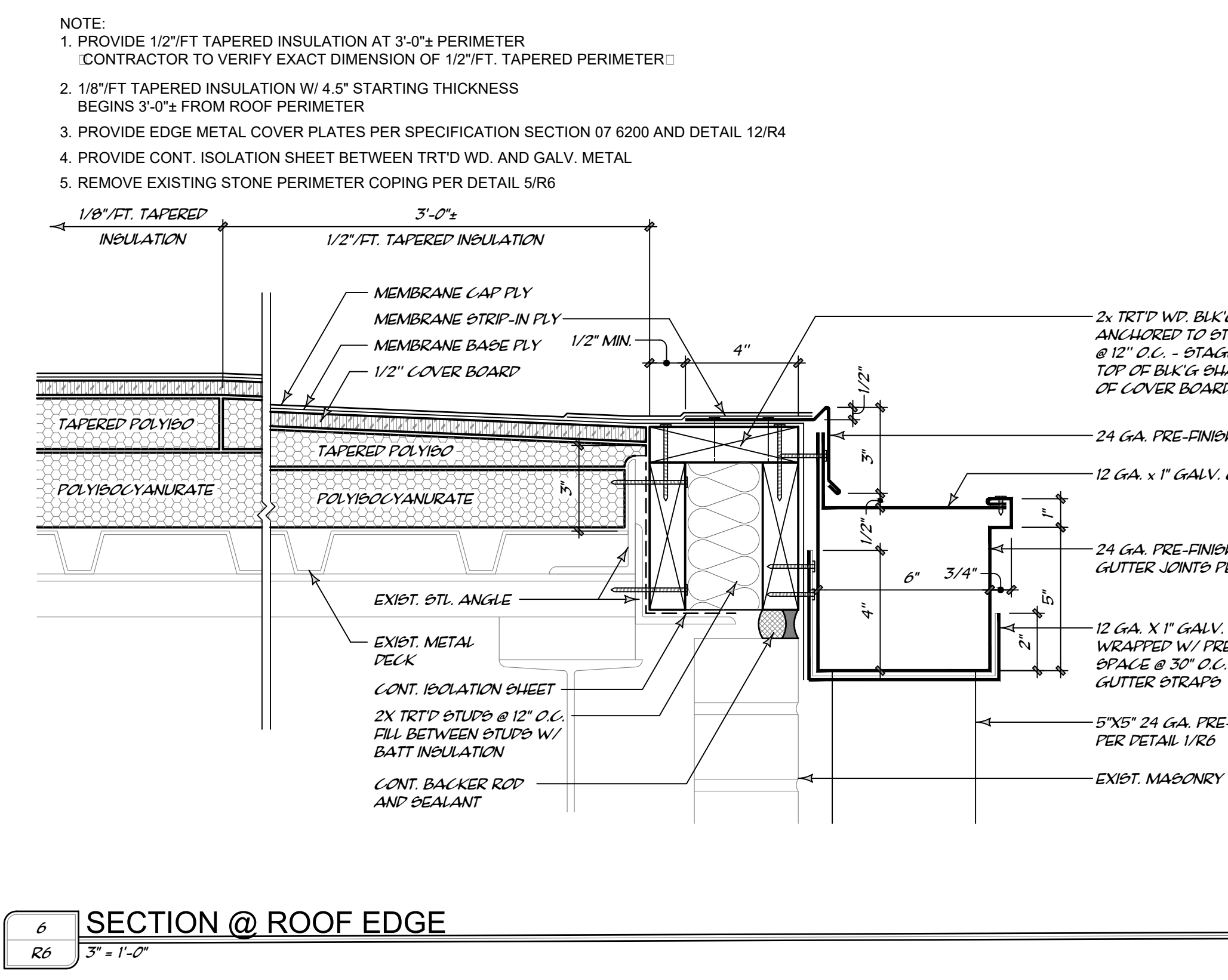
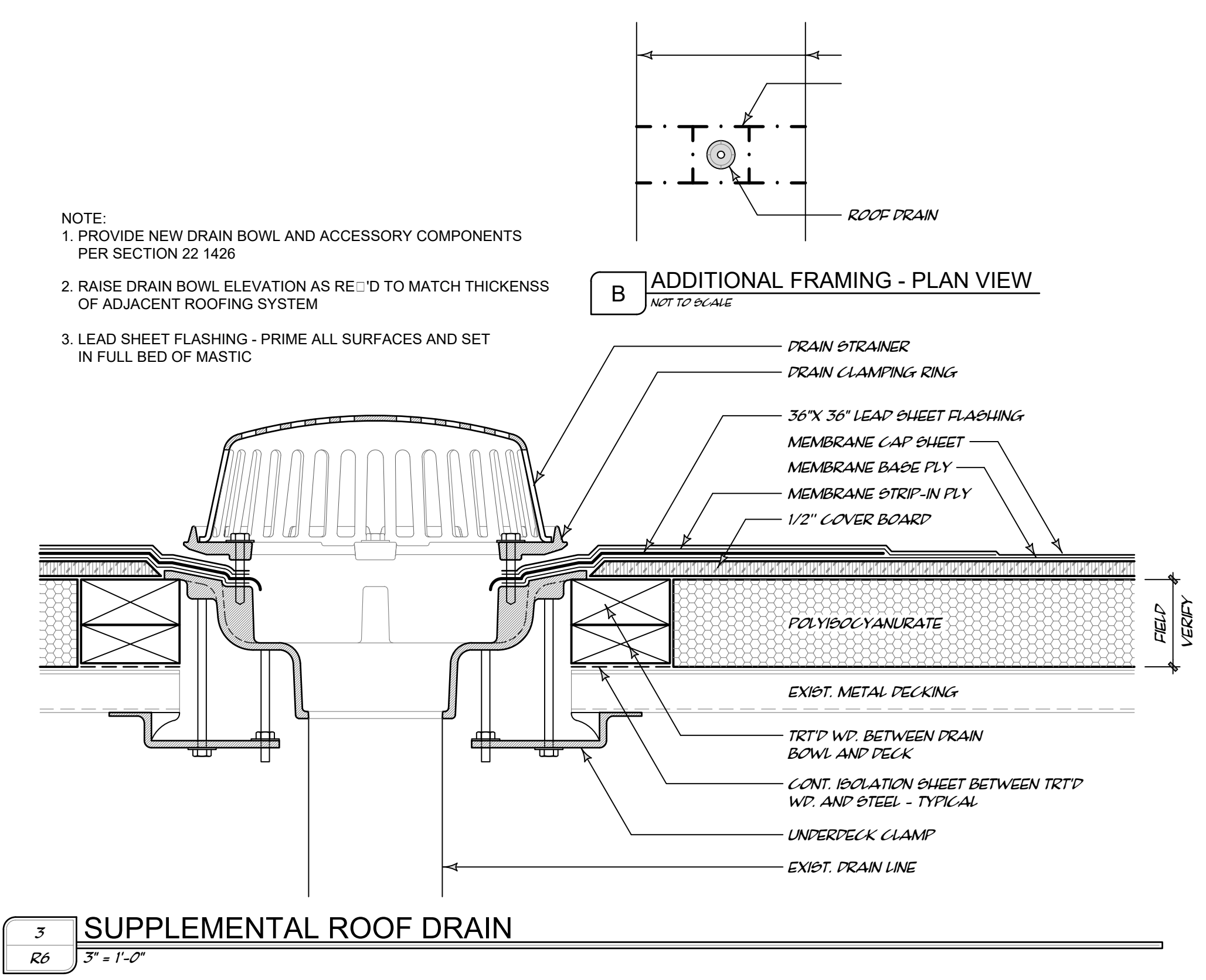
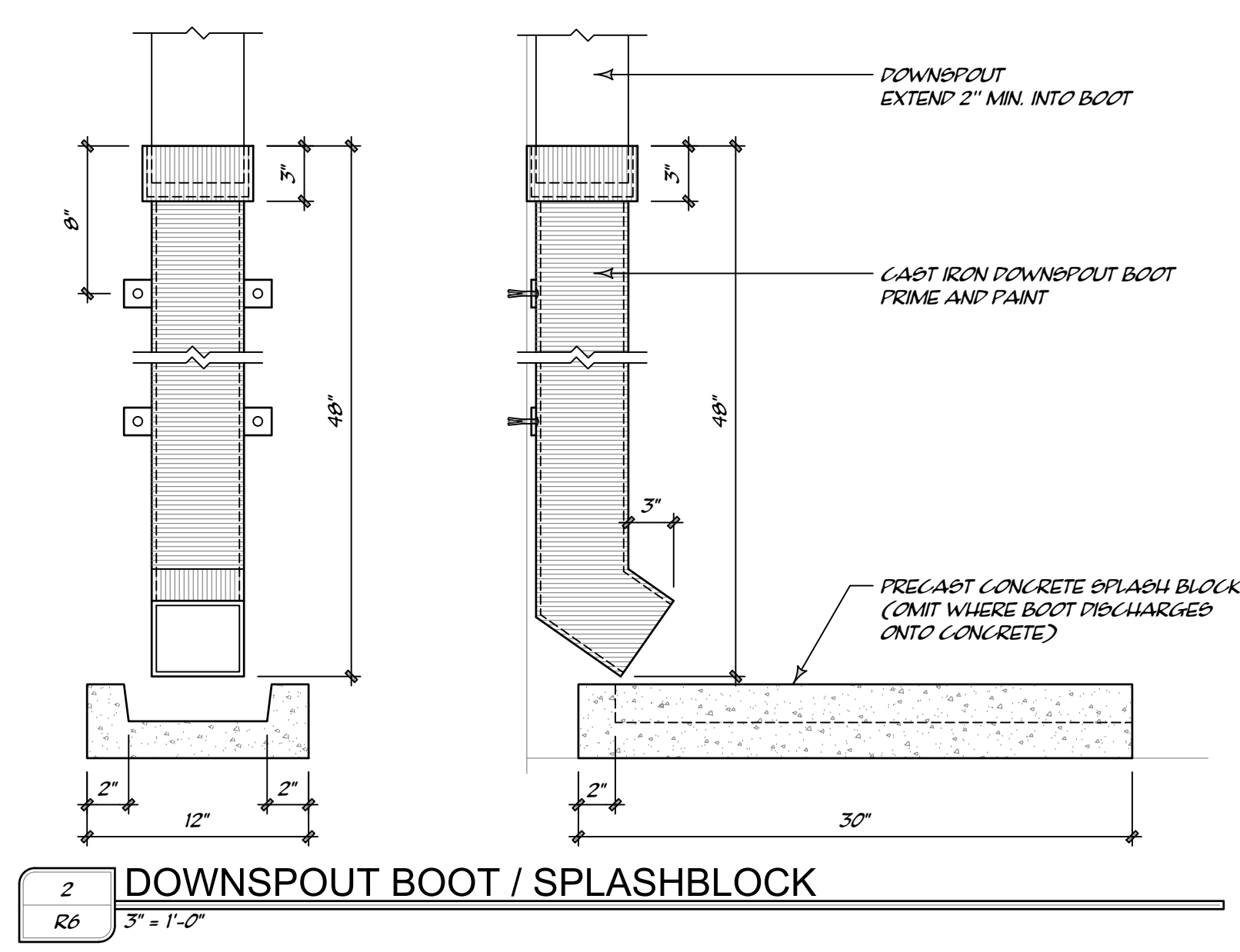
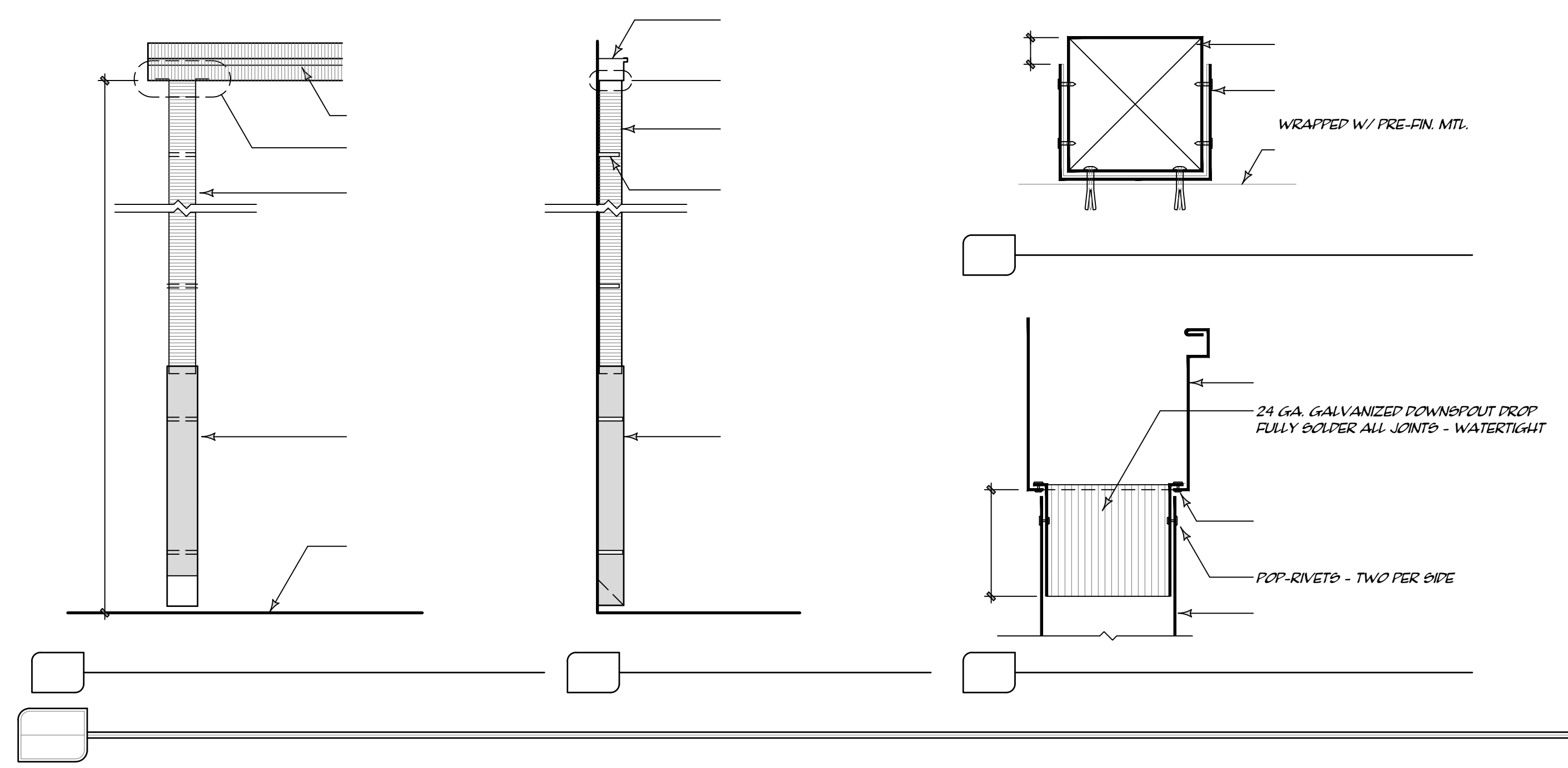

AUSTIN INDEPENDENT SCHOOL DISTRICT
ROOF REPLACEMENT
HOUSTON ELEMENTARY SCHOOL
5409 PONCIANA DR, AUSTIN, TX 78744
AISD PROJECT NO.: 18-0023-HOUST

REVISION SCHEDULE:

1.	
2.	
3.	
4.	
5.	
6.	
7.	



ROOFING DETAILS

DRAWN BY: MWH
CHECKED BY: JC
DATE: 09/21/2018
SHEET: R6 OF 7

REVISION SCHEDULE:	
1.	
2.	
3.	
4.	
5.	
6.	
7.	



ROOFING DETAILS

DRAWN BY:	MWH
CHECKED BY:	JC
DATE:	09/21/2018
SHEET:	

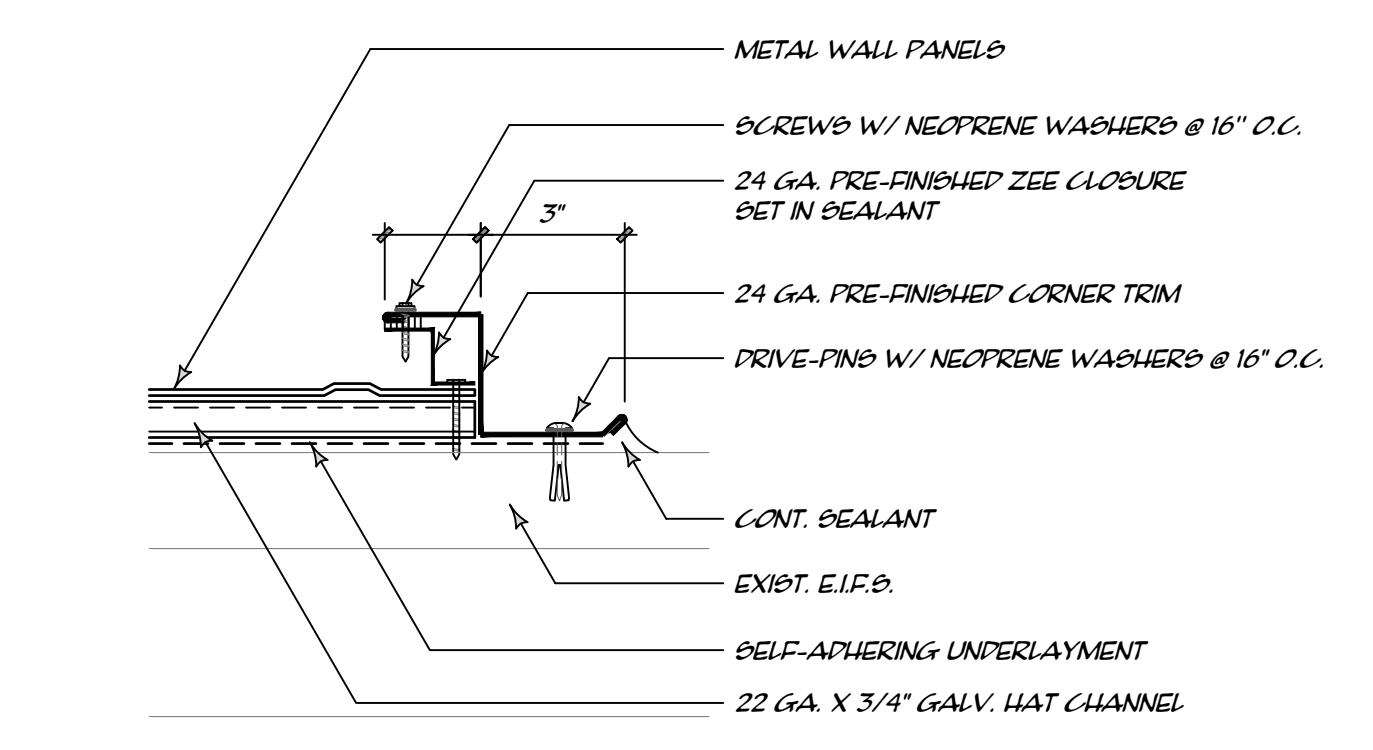
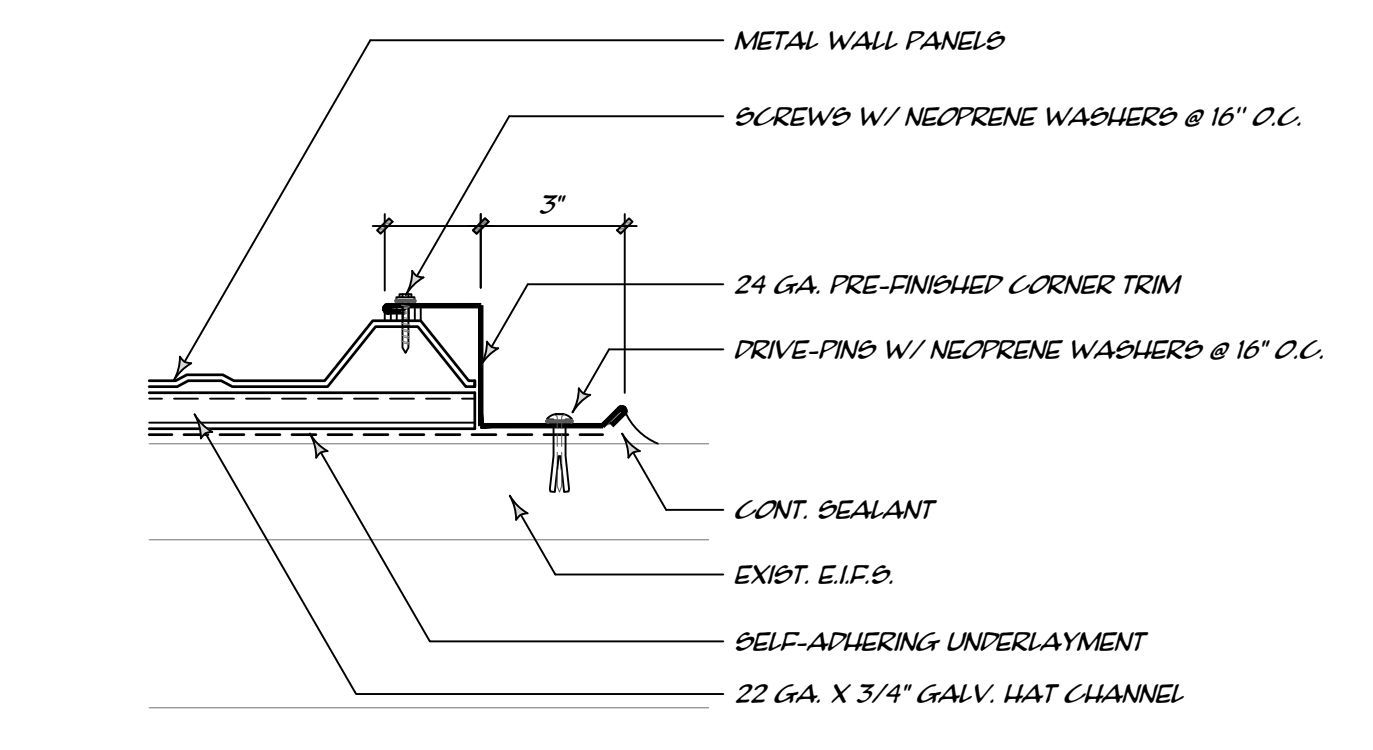
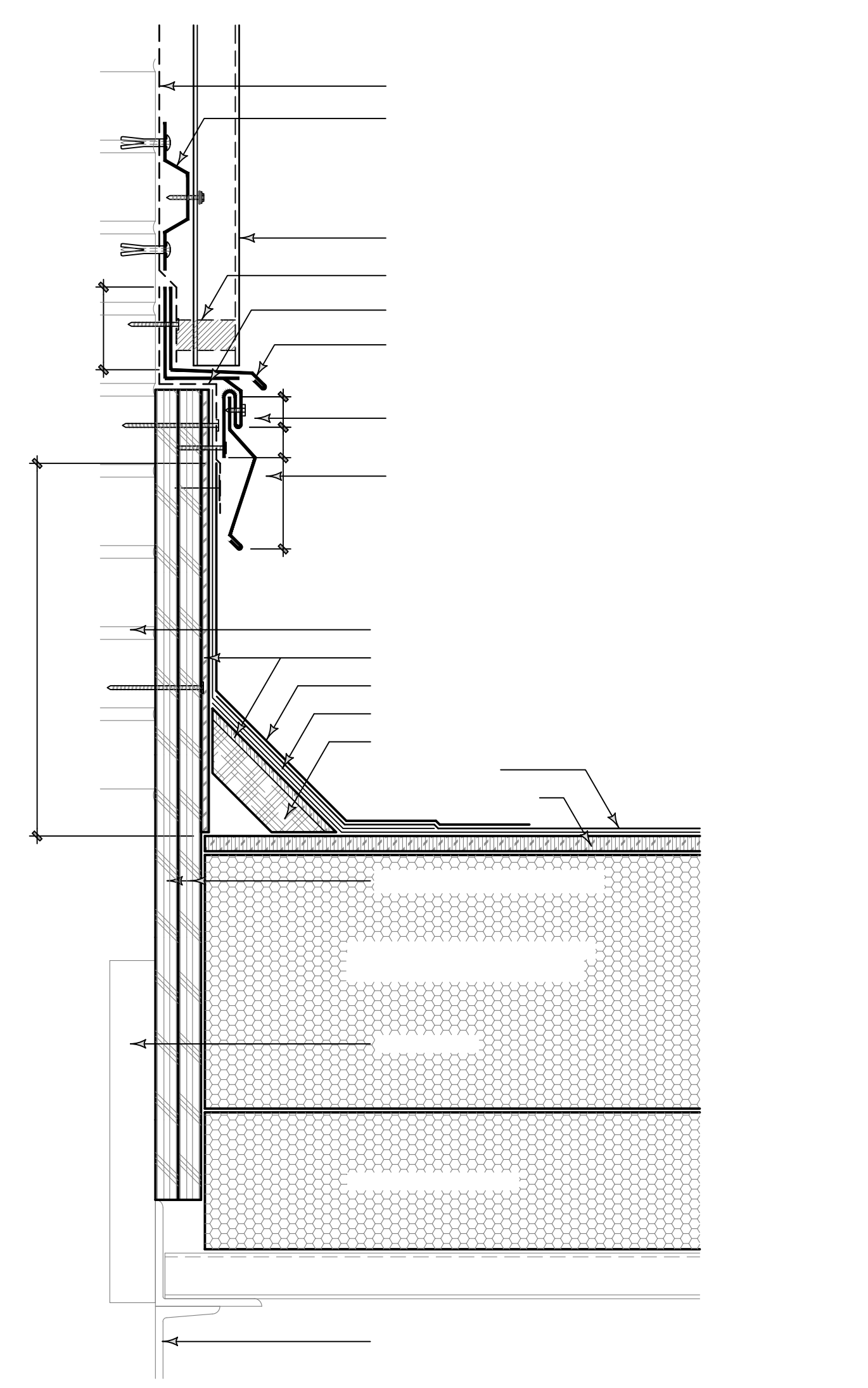

PLAN VIEW - WALL PANEL TERMINATION

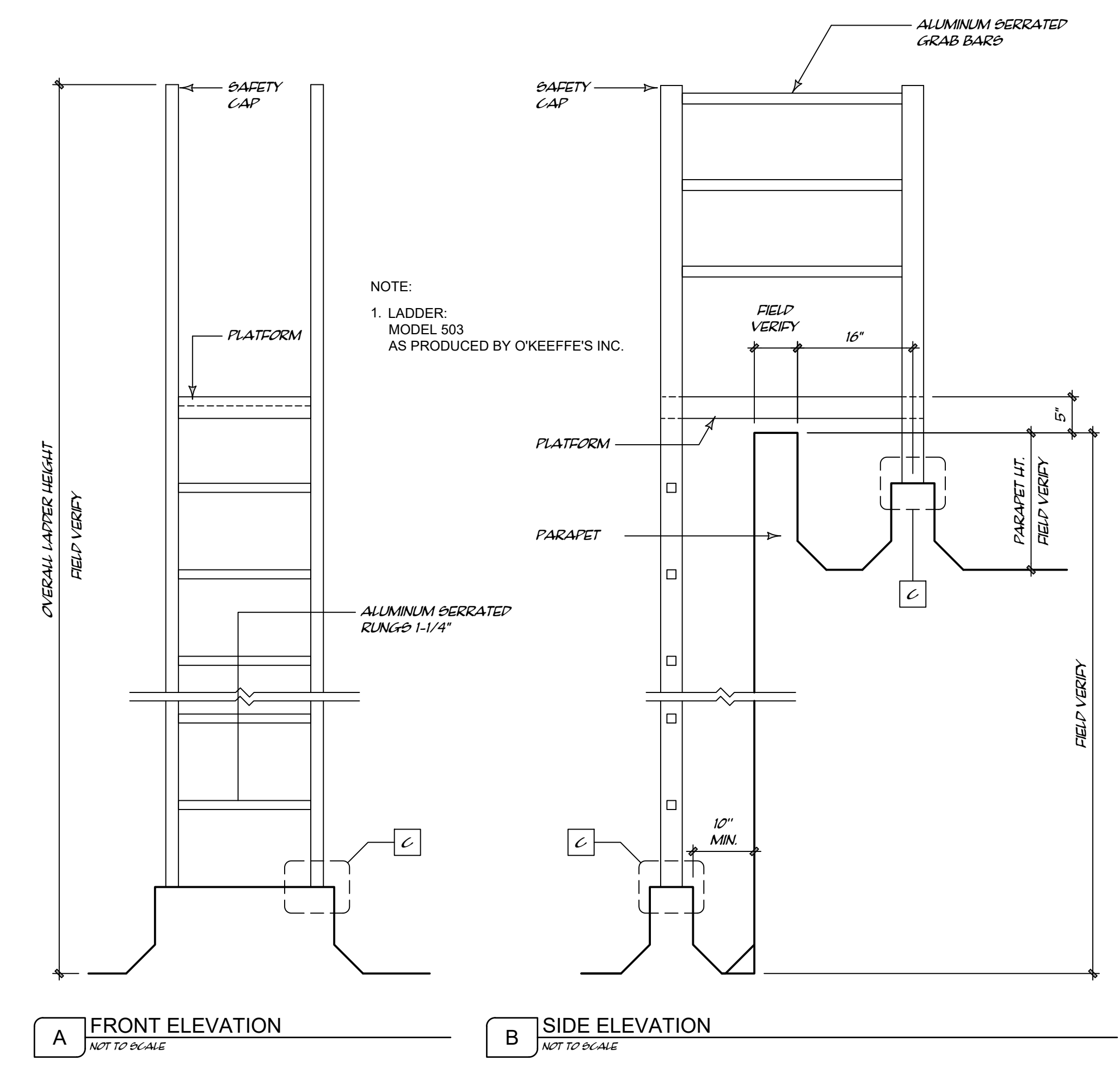

LADDER

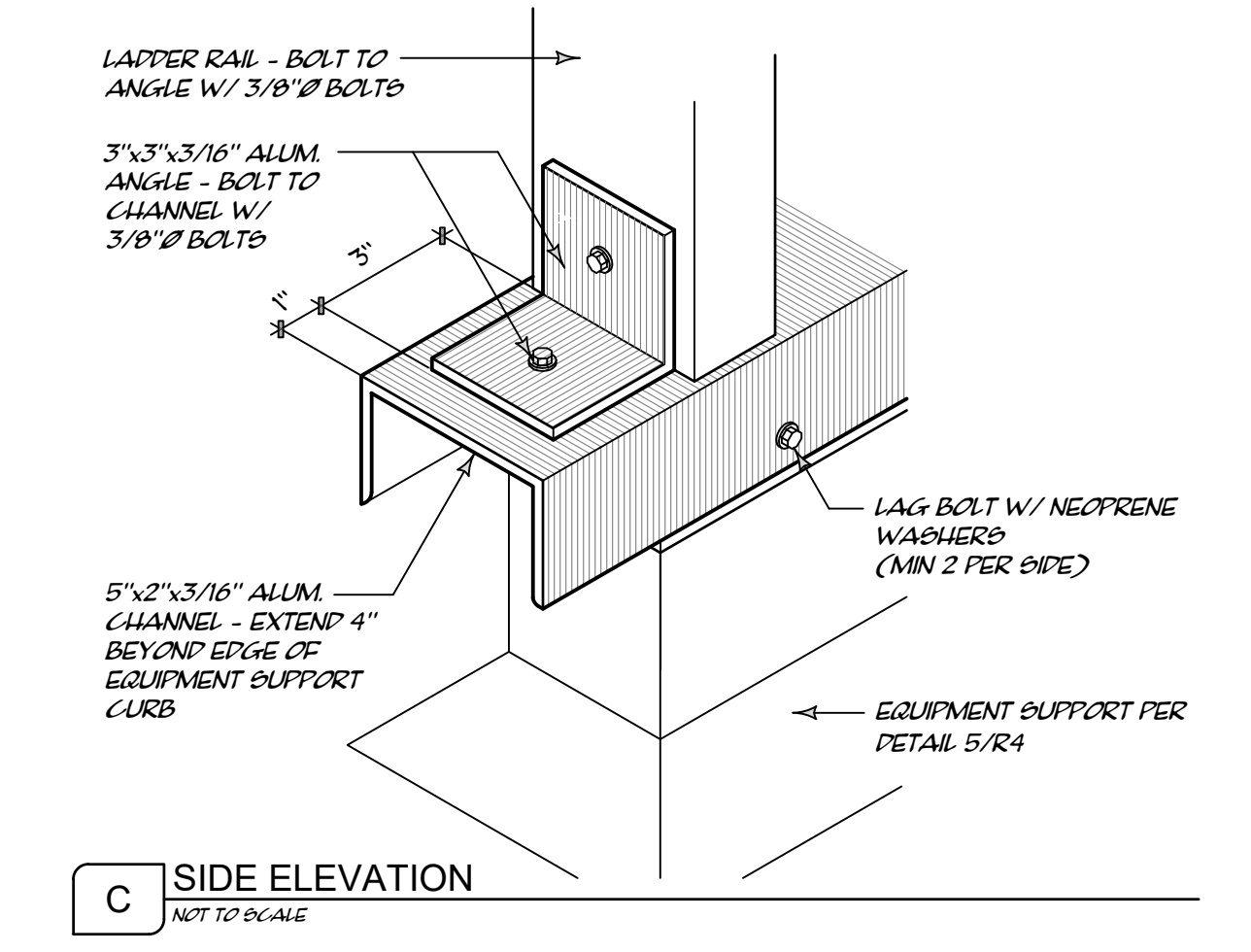

SIDE ELEVATION

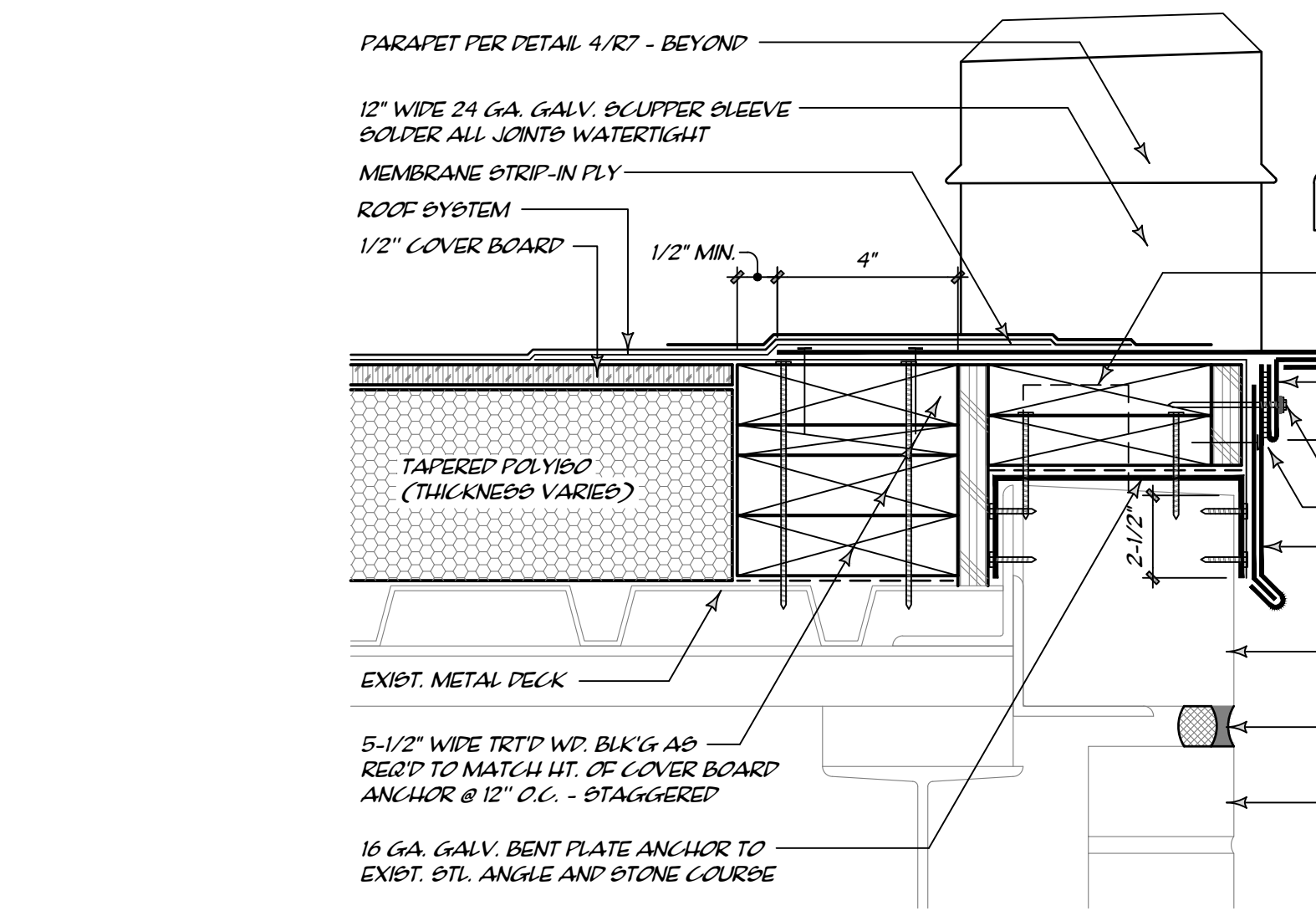
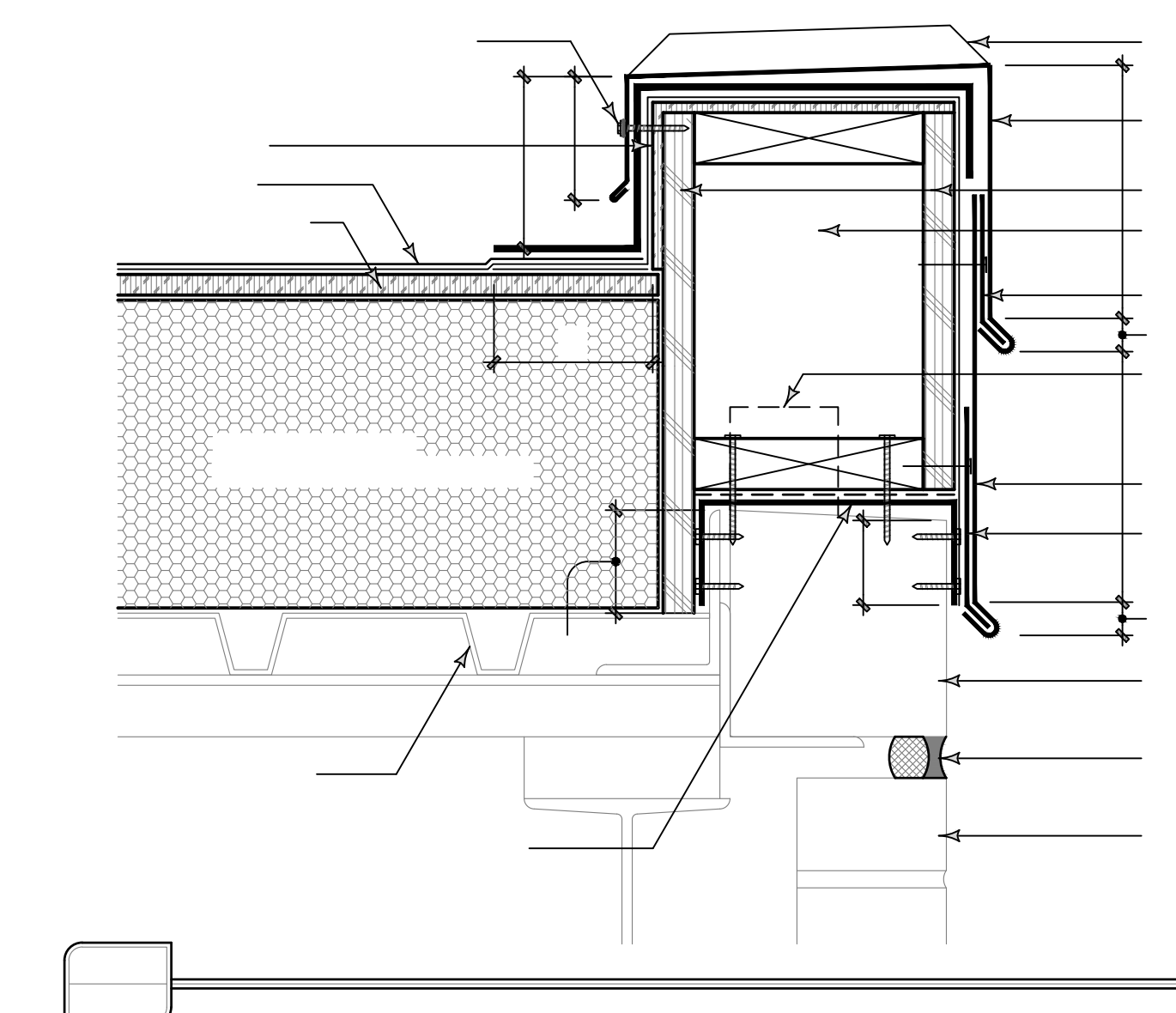

OVERFLOW SCUPPER

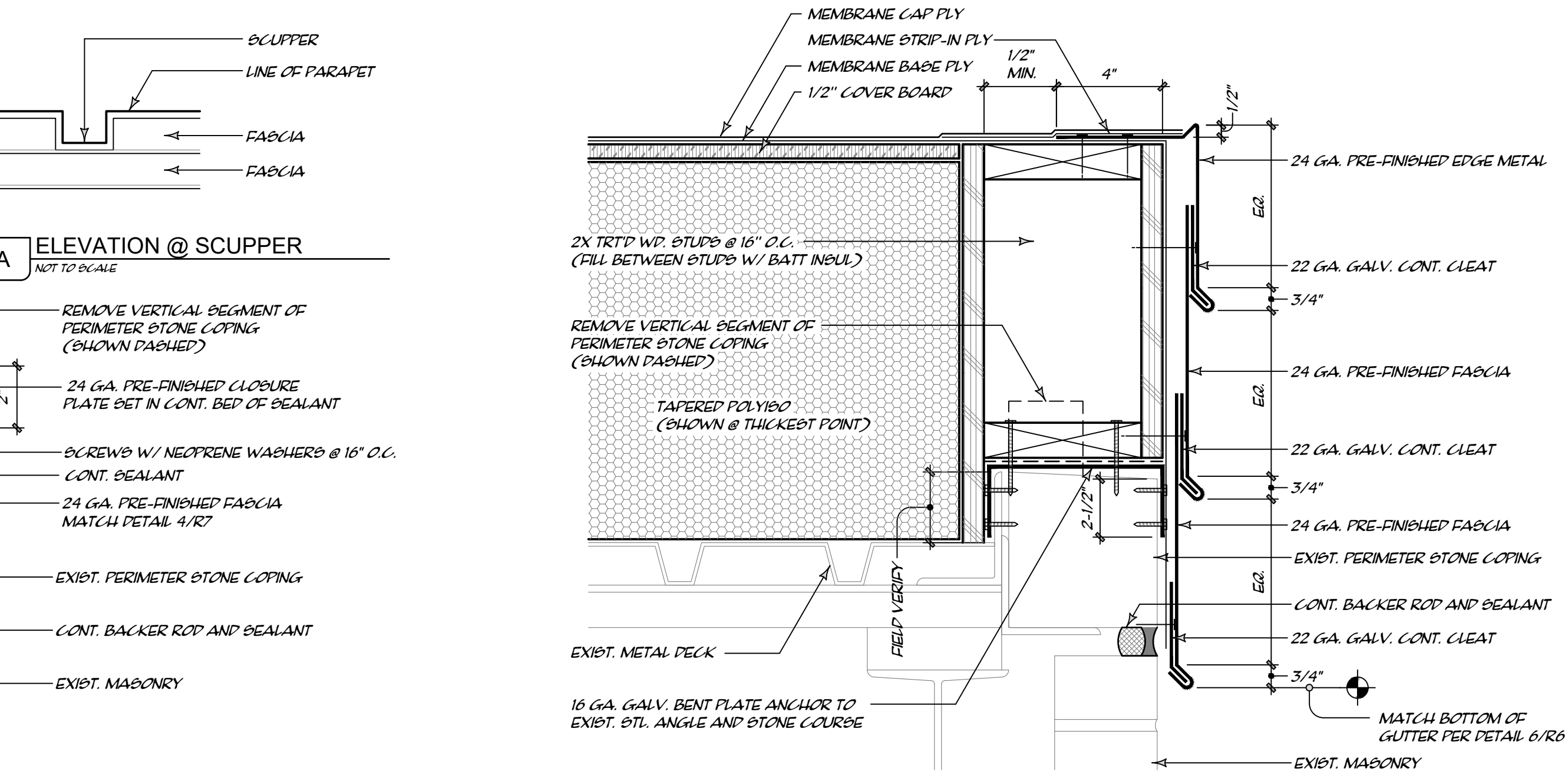

SECTION @ ROOF EDGE

- NOTE:
1. REMOVE EXISTING PERIMETER BLOCKING IN IT ENTIRETY
2. PROVIDE EDGE METAL COVER PLATES PER SPECIFICATION 07 6200 AND DETAIL 12/R4
3. PROVIDE CONT. ISOLATION SHEET BETWEEN TRTD WD. AND GALV. METAL